

Electronics Diversified, Inc.

SMART System User Manual

Revision 2.0, January 2003

©2003 Electronics Diversified, Inc.

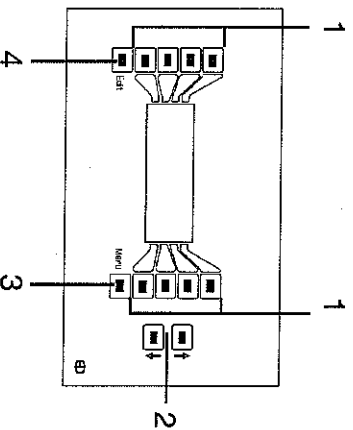

TABLE OF CONTENTS

OVERVIEW	
Master Station buttons.....	2
Connections.....	3
Power Consumption.....	3
PRESETS	
Overview.....	4
Activation.....	4
Editing.....	4
Global Presets.....	6
XGlobal Presets.....	8
STATIONS	
Overview.....	9
SlaveLCD.....	9
10 Button.....	12
2 Button.....	13
Digital Slider.....	14
Remote Device Interface.....	18
IR Remote Station.....	20
PATCH	
Overview.....	22
Patch Screen.....	22
Non-Dimming.....	23
COMBINES	
Overview.....	24
Activation.....	24
Overlapping Combines.....	24
Combine Setup.....	25
How: Preset vs. Zone.....	26
XGlobals.....	27
Patch Page switching.....	28
LOCKOUTS	
Overview.....	29
Setup Lockout Actions.....	29
Assign Lockout Actions.....	30
Lockout Override.....	30
Example 1: One preset lock.....	31
Example 2: Left-side preset lock, right-side preset unlock	33
TIMECLOCK	
Overview.....	37
Setup Clock.....	37
Setup Events.....	38
Turn On/Off Events.....	39
CONFIG SETTINGS	
Remote Edit.....	40
Password.....	40
Master Room Assignment.....	40
Activate Patch.....	41
Blackout.....	41
PASSWORD	
Changing Passwords.....	42
CLEARING THE SYSTEM	
Clearing and Setup.....	43
STATION WIRING	
Cabling.....	44
HARDWARE PIECES	
Overview.....	45
Removal of faceplate.....	45

OVERVIEW

MASTER STATION BUTTONS



1. Mapped Buttons:
Illuminating Buttons mapped to the display. Any button press results in the execution of the feature mapped to the button.

2. Up/ Down Buttons:
Allows user to control highlighted feature displayed by the Mapped Buttons. Mapped buttons are used to adjust levels, set time or course through character fields depending on their set function. Character fields will go SPACE, !, ", #, \$, %, &, ', (,), *, +, ,, ;, ,, 0 through 9, :, ,, <, =, >, ?, @, A through Z, [,], ^, _ , ' a through z.

3. Menu Button:
Gives access between the **preset menu** page and a menu of 8 other selections: ClearSys, Stations, DimPatch, Combines, Lockouts, Timers, Pass-word, and Config.

4. Edit Button:
When in the Preset activation page this button will allow the user to toggle between the 3 sets of preset pages. Within one of the Menu pages, it will allow the user to cycle through pages of one of the other topics: ClearSys, Stations, Dim Patch, Combines, Lockouts, Timers, Password, and Configurations.

OVERVIEW

CONNECTORS

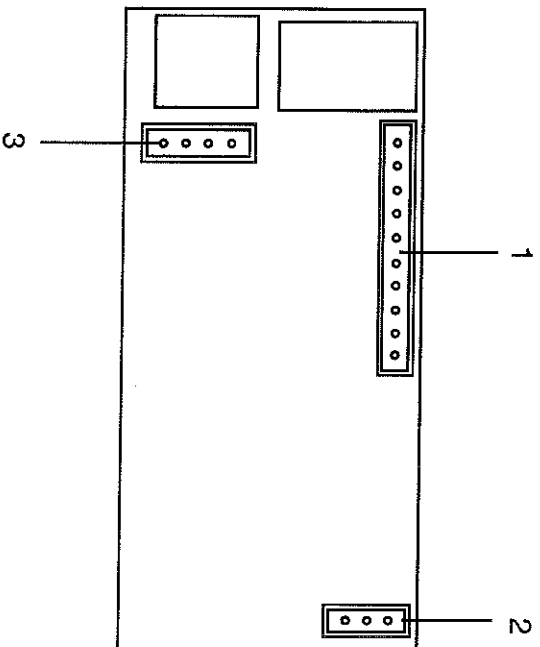

1. **Combines:**
PIN 1-8: Combine Inputs
PIN 10: Ground
2. **DMX Output:**
PIN 1: Ground
PIN 2: Data-
PIN 3: Data+
3. **Power/Serial Connection:**
PIN 1: Ground
PIN 2: Serial +
PIN 3: Serial -
PIN 4: +9 to 24 VDC

POWER CONSUMPTION

Operating Voltage: 9-24V

For small (1-8 Stations) systems 15VDC is sufficient. Larger systems (9-16 Stations) must use a 24VDC Power Supply.

Current (12VDC)	
Master Station	110mA
LCD Slave Station	50mA
2/10/IR Stations	60mA
Slider Stations	100mA*
RDI	100mA

* Rating based upon 10 channel slider. Lesser channel models will have a smaller maximum value.

PRESETS

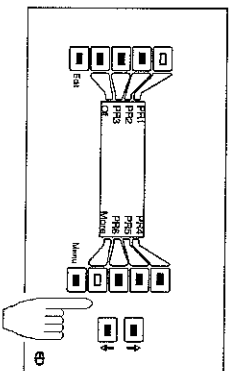

OVERVIEW

The SMART System has 117 presets total. Each of the 8 rooms have 13 user editable presets, plus 13 **XGlobal Presets**. The user has access to 7 presets at one time from the **Preset Menu**. To access the other six presets, press the **More** button. The 13th preset, labeled **OFF** will be accessible in both screens.

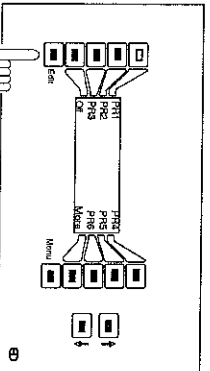

EDITING LEVELS/TIMES

**To Edit Presets,
Press Edit.**

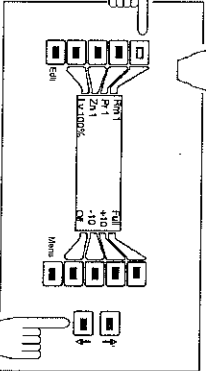

**Select Room:
Press Rm.
Use Up/Down buttons to
select room.**

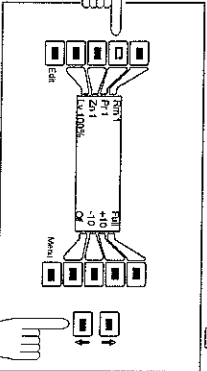

**Select Preset:
Press Pr.
Use Up/Down buttons to
select preset.**

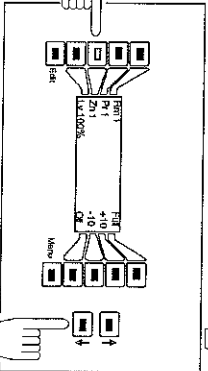

**Select Zone to be edited:
Press Zn.
Use Up/Down buttons to
select zone.**

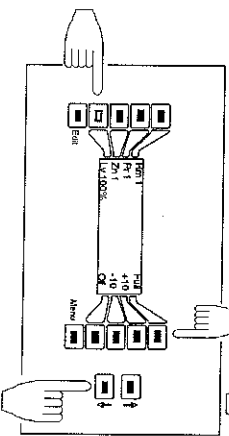

**Adjust Level:
Press Lv.
Use Up/Down buttons to
adjust level or use
Full, Off, +10 (increase by
10%) or -10% (decrease
by 10%).**

PRESETS

Set Fade Time: _____

Press Edit.

Select Tm.

Use Up/Down buttons to increment by seconds,

Min-/Min+ to increment by minutes and -10/+10

to increment by 10 second intervals.

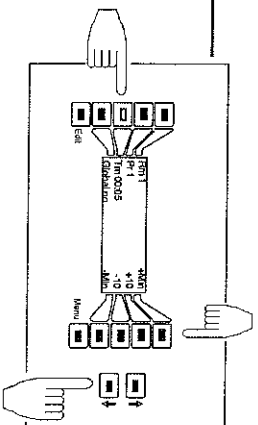

Name Preset: _____

Press Edit.

Select Name.

Use Up/Down buttons to select character. Character fields will go SPACE, I,"

#, \$, %, &, ' (), * +, ,, ' ,
 0 through 9, ;, <, =, >,
 ?, @, A through Z, [,], ^, _ ,
 ; a through z. Use I, 0, a,
 and A to quickly jump to
 characters.

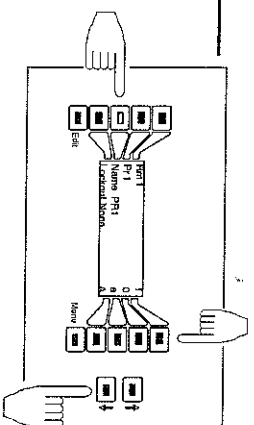

Return to Preset Menu:

Press Menu.

Note: All changes are being recorded while the user is editing.

PRESETS

GLOBAL PRESETS

Normal presets allow levels to be adjusted within a room and that room only. Global presets allow the user to adjust different zones in different rooms. Users can inhibit or "skip" zones so that they will not be affected by the preset. A global preset is most useful in cases where lights in distant rooms need to be turned on simultaneously or where a special preset is needed for system wide control.

From Preset Menu,
To create a global,
press **Edit**.

Select Room:
Press **Rm**.
Use **Up/Down** buttons to
select room for the preset.

Select Preset:
Press **Pr**.
Use **Up/Down** buttons to
select preset.

Activate Global Function for this Preset:
Press **Edit**.
Press **Global**.
Press **Up** button. The display
should change from **Global no** to
Global yes.

Select Room:
Press **Edit** twice. The display
should show **Global below Rm**
and **Pr** in the left hand part of the
screen.
Press **Edit** again. ***GLOBAL ***
should display at the top.
Press **Rm**.
Use **Up/Down** buttons to select
room.

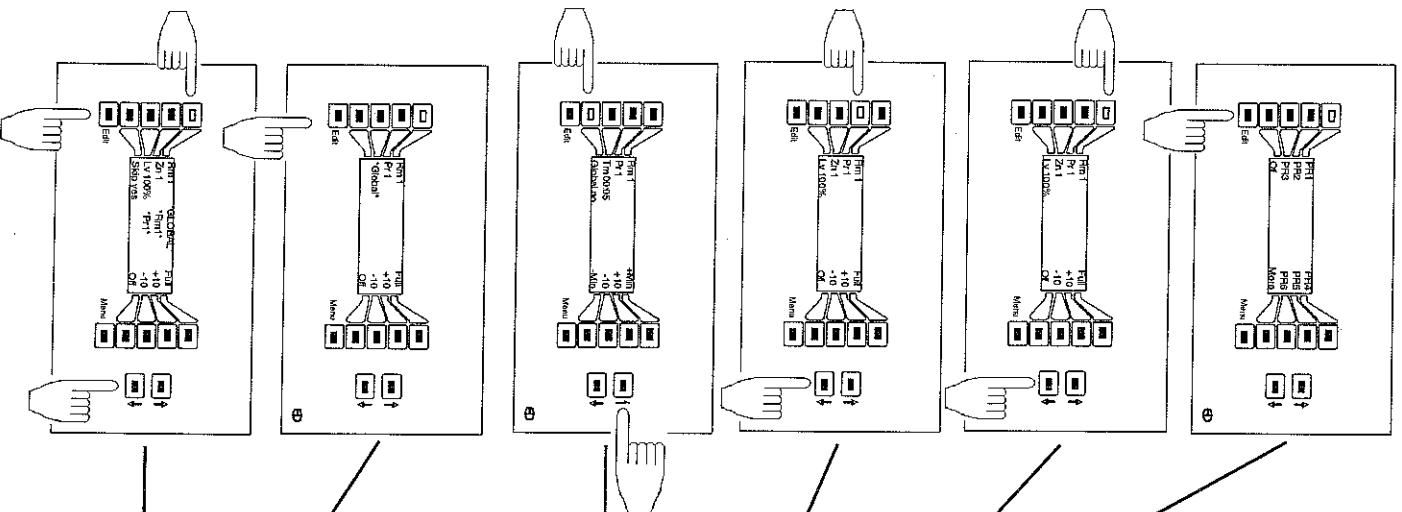

PRESETS

Select Zone to be edited:

Press **Zn**.
Use **Up/Down** buttons to select zone.

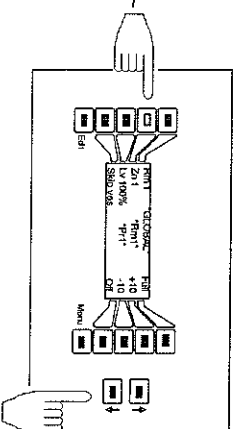

Adjust Level:

Press **Lv**.
Use **Up/Down** buttons to adjust level or use **Full,Off,+10** (increase by 10%) or **-10%** (decrement by 10%).

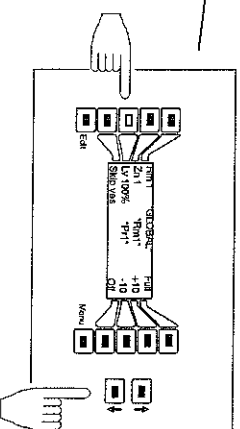

Unskip Zone:

Press **Skip**.
Press **Down** button. **Skip yes** should change to **Skip no**. A zone that is left on **Skip yes** will not be affected by this preset.

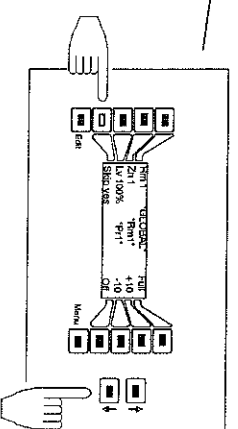

Set Fade Time:

Press **Edit**.
Select **Tm**.
Use **Up/Down** buttons increment by seconds. **Min~/Min+** increment by minutes and **-10/+10** to increment by 10 second intervals.

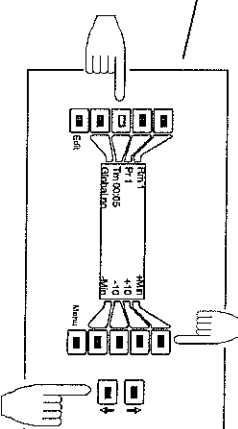

Name Preset:

Press **Edit**.
Select **Name**.
Use **Up/Down** buttons to select character. Character fields will go **SPACE, !, ", #, \$, %, &, ', (,), *, +, ,, -, ., 0 through 9, :, ;, <, =, >, ?, @, A through Z, [,], ^, _**, ' through z. Use **i, 0, a**, and **A** to quickly jump to characters.

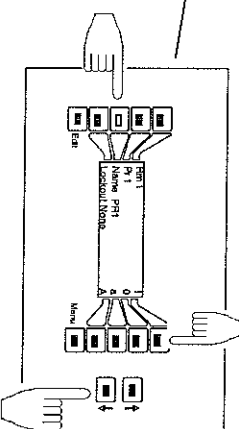

Return to Preset Menu:

Press **Menu**.

PRESETS

XGLOBAL PRESETS

13 XGlobal Presets can replace presets in combined rooms. The presets are not associated with any room, thus designated on the master station as X. Because they are a global preset, they will affect only those zones in rooms that are not "skipped". They can only be activated with a combine function and only be activated from stations within the combined room.

To assign an XGlobal Preset to a Combine function, turn to page 25.

From Preset Menu,
To create an XGlobal,
press Edit.

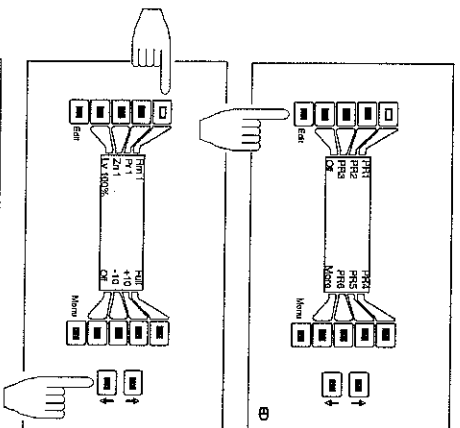

Select Room:

Press Rm.

Use Up button to select room

X. The display should show

Global below Rm and Pr in the

left hand part of the screen

Press Edit.

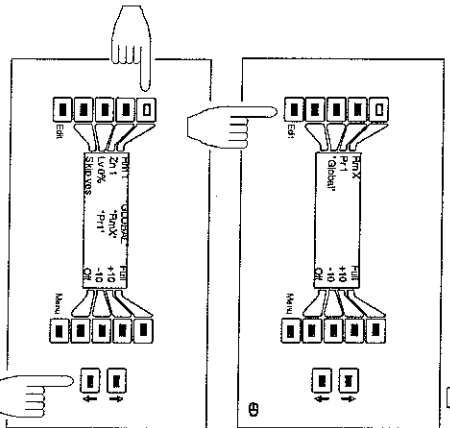

Select Roomto Edit:

Press Edit again. *GLOBAL*
should display at the top.

Press Rm.

Use Up/Down buttons to select
room.

Follow the directions on page 7 for
editing Global presets.

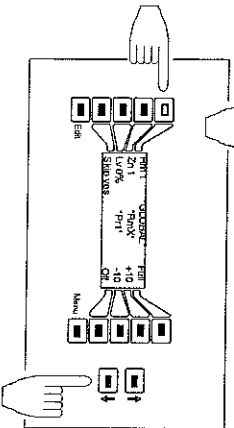

STATIONS

OVERVIEW

The SMART System can handle up to 16 stations:

- 6 types of stations are available on the SMART System: LCD Slave, 10 Button, 2 Button, Digital Slider, IR Remote, and Remote Device Interface.
- Stations can be spread out over 1000 feet of Alpha 1133.
- The SMART System can only address one station and cannot allow "mirroring" of stations.
- The Master Station itself can be used as a station and is non addressable.
To read how to select the room the Master station will operate turn to page 31.

SLAVE LCD STATION

1. Mapped Buttons:

Illuminating Buttons mapped to the display. Any button press results in the execution of the feature mapped to the button.

2. Up/Down Buttons:

Allows user to control highlighted feature displayed by the Mapped Buttons. Used to adjust levels or set time.

3. Menu Button:

Returns to the **preset menu** page.

4. Edit Button:

Prompts for the next page within the Preset edit pages

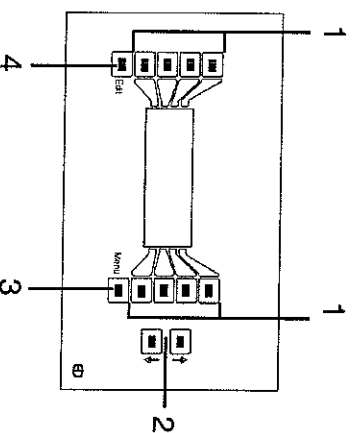

STATIONS

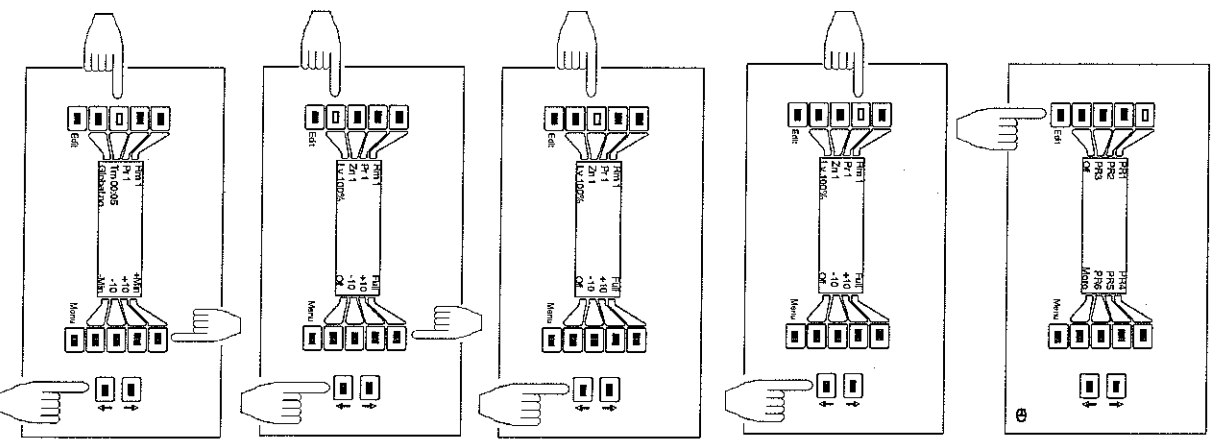

**To Edit Presets,
Press Edit.**

Select Preset:
Press **Pr.**
Use **Up/Down** buttons to
select preset.

Select Zone to be edited:
Press **Zn.**
Use **Up/Down** buttons to
select zone.

Adjust Level:
Press **L.V.**
Use **Up/Down** buttons to
adjust level or use
Full, Off, +10 (increase by
10%) or **-10%** (decrease by
10%).

Set Fade Time:
Press **Edit.**
Select **Tm.**
Use **Up/Down** buttons to
increment by seconds,
Min-/Min+ to increment
by minutes and **-10/+10**
to increment by 10
second intervals.

Return to Preset Menu:
Press **Menu.**

STATIONS

SETUP LCD:

From Preset Menu,
On the Master Station,
Press Menu. Main Menu displays.

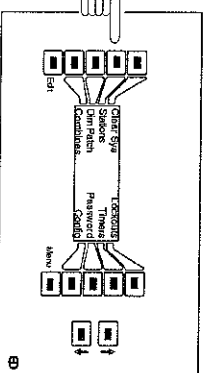

Press Stations.

Press Station 0.
Use Up/Down arrows to select a Station. In the station name, LCD refers to a Slave LCD Station.

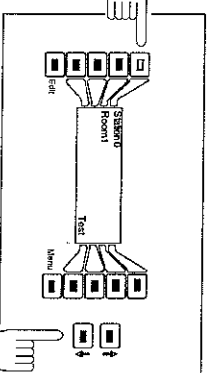

Select Room:
Press Room.

Use Up/Down buttons to assign a room to a station.

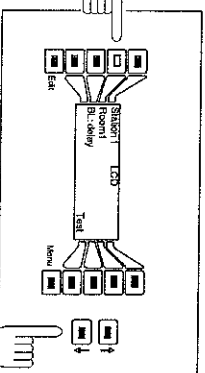

Select Backlight:
Press BL.

Use Up/Down button to select between backlight constant on, constant off, or instant on/ delay off.

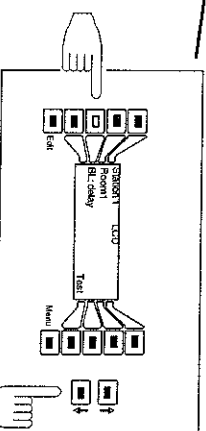

Test the Station:
Press Test.

Station will flash LEDs
Press any other button to resume normal functions.

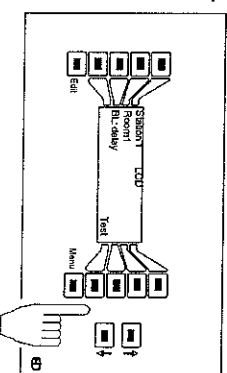

Return to Preset Menu:
Press Menu.

STATIONS

10 BUTTON STATION

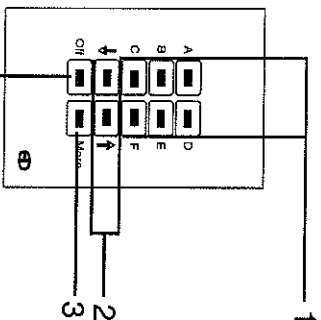

1. **Presets 1-6 (7-12 when More is activated)**
Press a button to execute a preset in a room
2. **Master Room Level Buttons**
Adjust levels up or down in all zones within a room.
3. **More Button**
Switches between Presets 1-6 and 7-12
- 4 **Off Button**
Press to Execute Preset 13 (Off)

SETUP 10 BUTTON:

From Preset Menu,

On the Master Station,
Press **Menu**. **Main Menu displays**

Press **Stations**.

Press **Station 0**.

Use **Up/Down** arrows to select a Station. In the station name, **10Btn** refers to a 10 Button Station.

Select Room:

Press **Room**.

Use **Up/Down** buttons to assign a room to a station.

Test the Station:

Press **Test**.

Station will flash LEDs

Press any other button to resume normal functions.

Return to Preset Menu:

Press **Menu**.

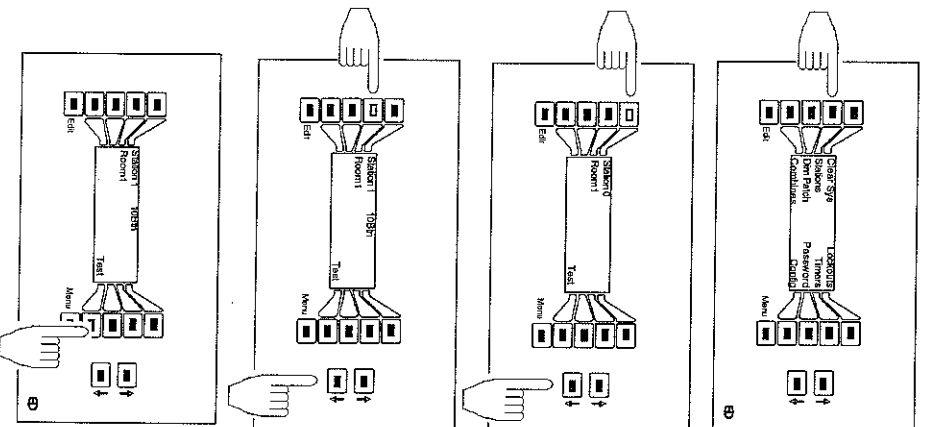

STATIONS

2 BUTTON STATION

1. **On Button**
Press button to execute an assigned preset (see below).
2. **Off Button**
Press button to execute preset 13 (Off)

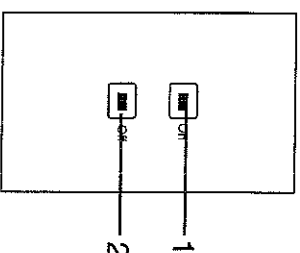

SETUP 2 BUTTON:

From Preset Menu,
On the Master Station,
Press Menu. Main Menu Displays.

Press Stations.
Press Station 0.
Use Up/Down arrows to select a Station. In the station name, **2Btin** refers to a 10 Button Station.

Select Room: _____
Press Room.
Use Up/Down buttons to assign a room to a station.

Select On Preset: _____
Press On preset.
Use Up/Down buttons to assign a preset on a button.

Test the Station: _____
Press Test.
Station will flash LEDs
Press any other button to resume normal functions.

Return to Preset Menu: _____
Press Menu.

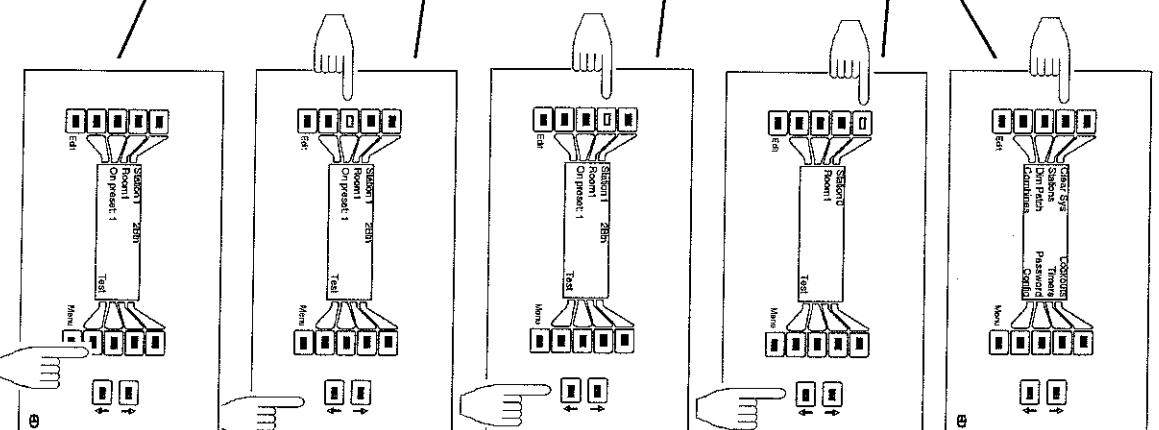

STATIONS

DIGITAL SLIDER STATION

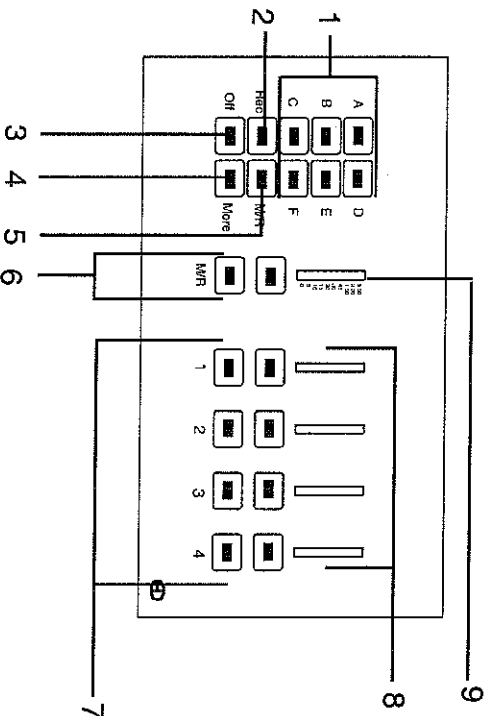

- 1. Presets 1-6 (7-12 when More is activated)**
Press a button to execute a preset in a room.
- 2. Record Button**
Used in saving levels to a preset. Also, this button is used for paging different channels. (See recording presets and changing zone pages on pages 15 and 16).

- 3. Off Button**
Press to Execute Preset 13 (Off).

- 4. More Button**
Toggles between Presets 1-6 and 7-12.

- 5. Master/Fade Rate Button**
Toggles the M/R display (9) from displaying master control use and the fade rate of an executed preset. It will also toggle the use of the M/R level controls (6) from adjusting all zones within a room to adjusting preset fade rates when recording.

- 6. Master/Fade Rate Control**
Press to raise or lower level in a room or adjust fade rate as desired (See recording presets about fade rate changes on page 15).

- 7. Channel Level Controls**
Press to raise or lower an individual channel level within a room.

- 8. Channel Levels**
10-segment LEDs show intensity values from 0 to 100% on each channel.

- 9. M/R Levels**
10-segment LEDs shows master fader action and fade rates up to 5 minutes.

STATIONS

To Record a Preset: _____

Adjust **Channel Level Controls** to desired levels.

Press and hold **Record** button.

Press **Preset** to be stored in.

Release both buttons.

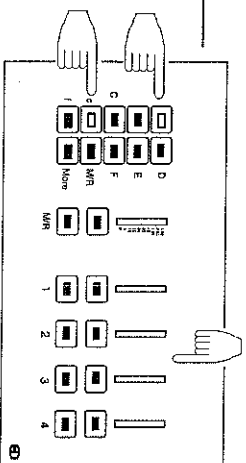

View Fade Rate:

Press **M/R** button.

To Change **Fade Rate of a Preset:** _____

View **Fade Rate**.

Press and hold **Record** button.

Use **M/R Control** to raise or lower fade rate.

Release **Record** when finished editing. This changes the fade rate of the active preset.

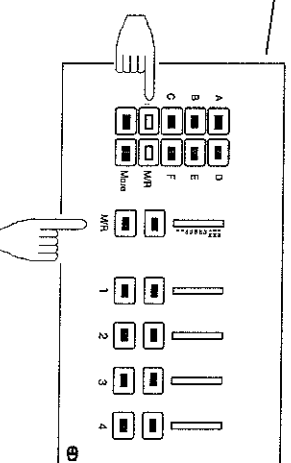

CHANGING ZONE PAGES:

Slider stations have programmable zonal paging, allowing the user to edit all or some of the zones within a room regardless of slider station configuration and zones within a room. The user can view 4, 6, 8, or 10 zones at a time (based upon how many slider controls there are). The user can advance or "page" to another group of zones within the room. Thus on a 4 channel slider the user can view the following zones: 1 through 4 on the first page, 5 through 8 on the second page, 9 through 12 on the third page, and 13 through 16 on the fourth.

STATIONS

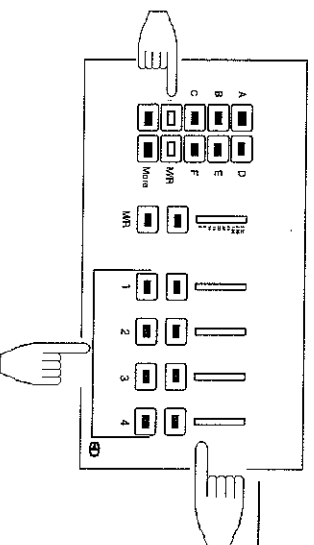

To Change Zone Page,
 Press **Record** button and **Down Zone** button on the page to be viewed (Ex. First Page would be the first **Down Zone** button). The lowest LED over the slider button will flash.

Note: The LED for the first page will not flash.

SETUP SLIDER STATION:

From Preset Menu,
 On the Master Station,
 Press **Menu**. Main Menu displays.
 Press **Stations**.
 Press **Station 0**.

Use **Up/Down** arrows to select a Station. In the station name, **Slidr** refers to a Slider Station.

Select Room:

Press **Room**.
 Use **Up/Down** buttons to assign a room to a station.

Set Channel Size of Slider :

Press **Channels**.
 Use **Up/Down** buttons to designate the maximum number of zones that can be displayed on that station.

Test the Station:

Press **Test**.
Station will flash LEDs
 Press any other button to resume normal functions.

Return to Preset Menu:
 Press **Menu**.

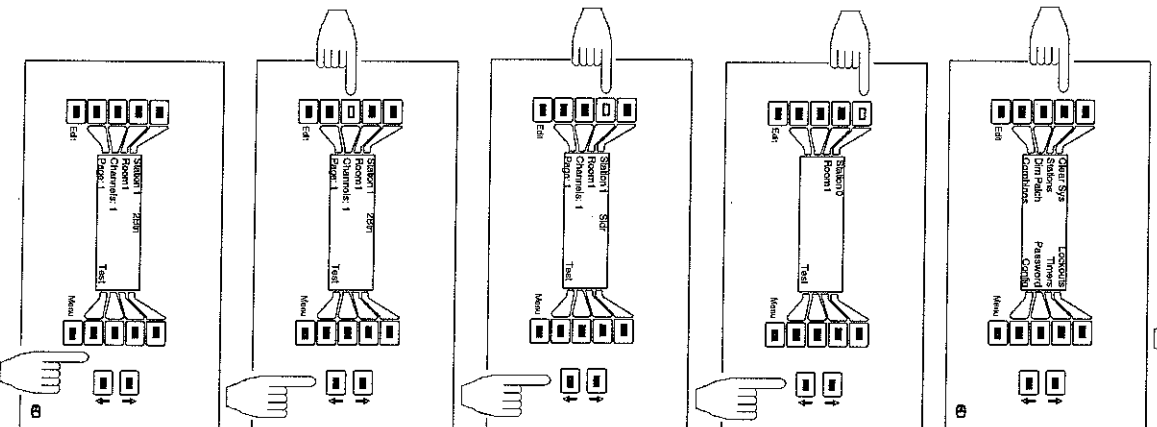

STATIONS

REMOTE DEVICE INTERFACE

OVERVIEW

The Remote Device Interface (RDI) allows the SMART System to communicate with other devices through maintain or momentary switching. Each port has a latched(On) function and unlatched(Off) function, allowing the user to activate to separate functions on one switch (Example: Preset 1 for Port1 On function and Preset Off for port 1 Off function). This is useful for turning on and off combines or a blackout switch for a room. Momentary switching can be used by setting the On and Off functions to the same setting. (Example: Preset 1 for Port 1 On and Off functions and Preset Off for Port 2). A custom keypad for a master control panel/switchboard may use momentary switching on the RDI to activate functions throughout the SMART System.

1. PIN 1-12: input port latches
 PIN 13: common for input port latches
 PIN 14: 9-24VDC from LAN
 PIN 15: Ground from LAN
2. Input LEDs 1-12: lamp on when latch is closed by outside source
3. PIN 1-12: output port latches
 PIN 13: common for output port latches
4. Output LEDs 1-12: lamp on when RDI has closed the latch

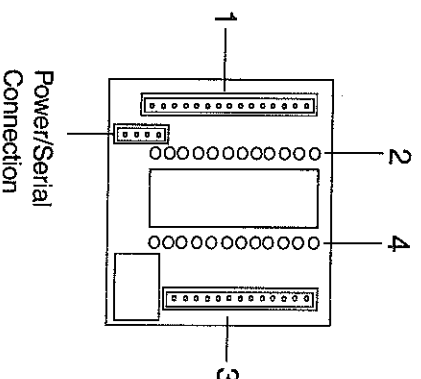

STATIONS

SEUP RDI FUNCTIONS:

From Preset Menu,
On the Master Station,
Press Menu. Main Menu displays.

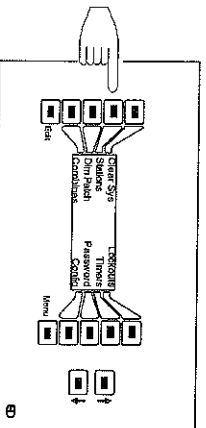

Press Station 0.
Use Up/Down arrows to select a Station. In the station name, RDI refers to the Remote Device Interface.

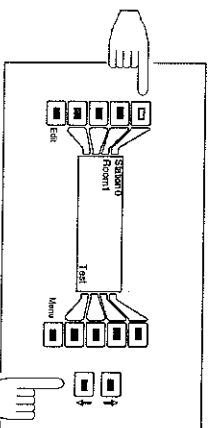

Select a Port:
Press Port.
Use the Up/Down buttons to select an input or output port latch (1-12).

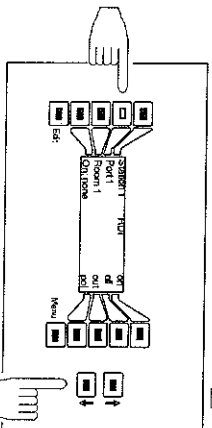

Select a Room:
Press Room.
Use the Up/Down buttons to select a room that RDI will activate or sense. The same port can be used for multiple rooms.

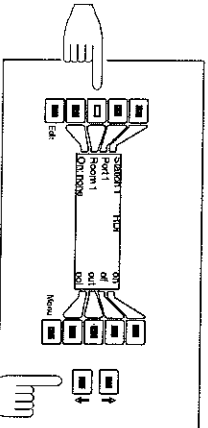

Select an On Function:
Press the 4th button down on the left. When this button is lit, the user can designate functions to the RDI
Press on
Use Up/Down buttons to select an action for the given room when the input port has been latched. The RDI can:

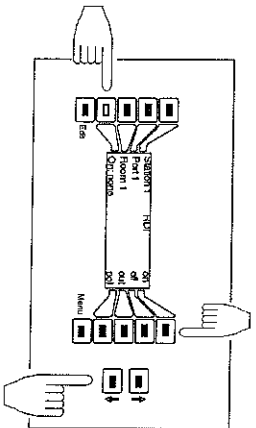

- Blackout/ un-Blackout
- Turn the timeclock operations on or off execute
- Presets 1-13
- Combine or UnCombine 1-8.

STATIONS

Select an Off Function :

- Press **off**
- Use **Up/Down** buttons to select an action for the given room when the input port is open. The RDI can:
 - Blackout/ un-Blackout
 - Turn the timeclock operations on or off execute
 - Presets1-13
 - Combine or UnCombine
 - 1-8.

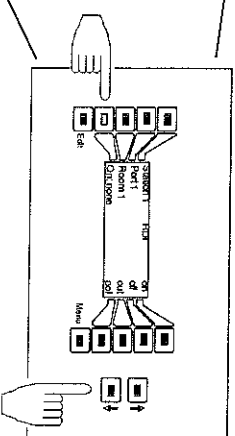

Select an Output Function :

- Press **out**
- Use **Up/Down** buttons to latch the output port for a given executed preset
- The RDI can respond to the following actions:
 - Blackout/ un-Blackout,
 - Turn the timeclock operations on or off,
 - Execution of Presets1-13,
 - Combine or UnCombine 1-8.

POLARITY:

This determines whether or not the Remote Device Interface should keep an active high or active low on a selected port.

Give the Polarity of the Port:

- Press **pol.**
- Press **Up** button for the RDI to pull up high to latch or signal action. The display will show **Pol: high**. Press
- Down** button for the RDI to pull down low to latch or signal action. The display will show **Pol: low**.

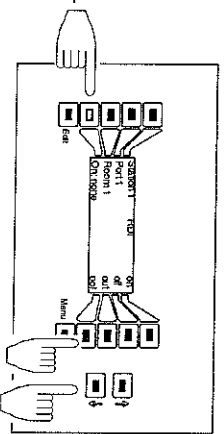

Return to Preset Screen:

Press **Menu**.

STATIONS

IR REMOTE STATION

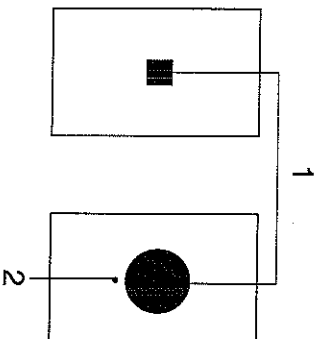

IR STATION:

- 1. **IR Sensor**
Receives infrared signals from remote control
- 2. **LED Indicator**
Indicates function execution has been received

IR REMOTE CONTROL:

- 1. **Presets 1-12**
Press a button to execute a preset in a room
- 2. **Master Room Level Buttons**
Adjust levels up or down in all zones within a room.
- 3. **Off Button**
Press to Execute Preset 13 (Off)
- 4. **LED Indicator**
Indicates function execution has been transmitted

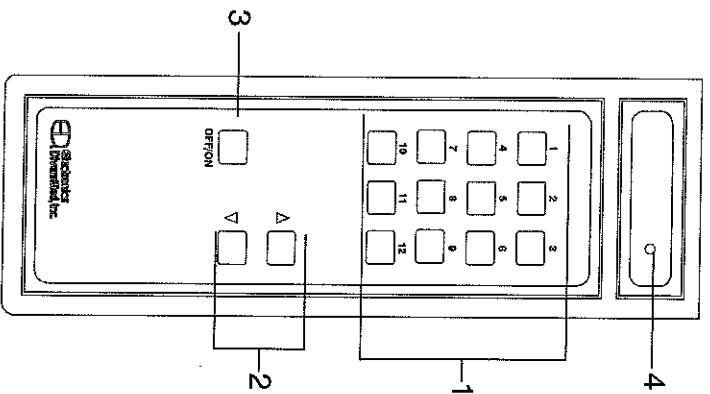

STATIONS

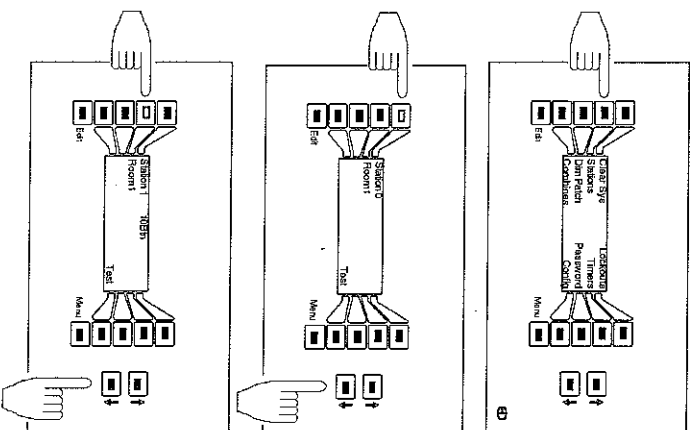

SETUP IR REMOTE:

From Preset Menu,
On the Master Station,
Press Menu. Main Menu displays
Press Stations.

Press Station 0.
Use Up/Down arrows to select a
Station. In the station name, IR
refers to a 10 Button Station.

Select Room:
Press Room.
Use Up/Down buttons to assign a
room to a station.

Return to Preset Menu:
Press Menu.

PATCH

OVERVIEW

The SMART System Patch Panel allows 250 dimmers to be patched to a maximum of 100 channels or zones. Nine individual patch pages can be stored and can be activated manually through the Config page (see page 39) or through Combine Actions (see page 26).

PATCH SCREEN:

From the Preset Menu,
To edit the configuration of a dimmer,
 Press Menu. Main Menu displays.
 Press Dim Patch.

Select a Patch Page to edit:
 Press Patch.
 Use Up/Down buttons to select patch page.

Select Dimmer to configure:
 Press Dim.
 Use Up/Down buttons to select patch page.

Assign a Dimmer to a Room:
 Press Room.
 Use Up/Down buttons to assign dimmer to a room.

Assign a Dimmer to a Zone within the room:
 Press Zone.
 Use Up/Down buttons to assign dimmer to a zone.

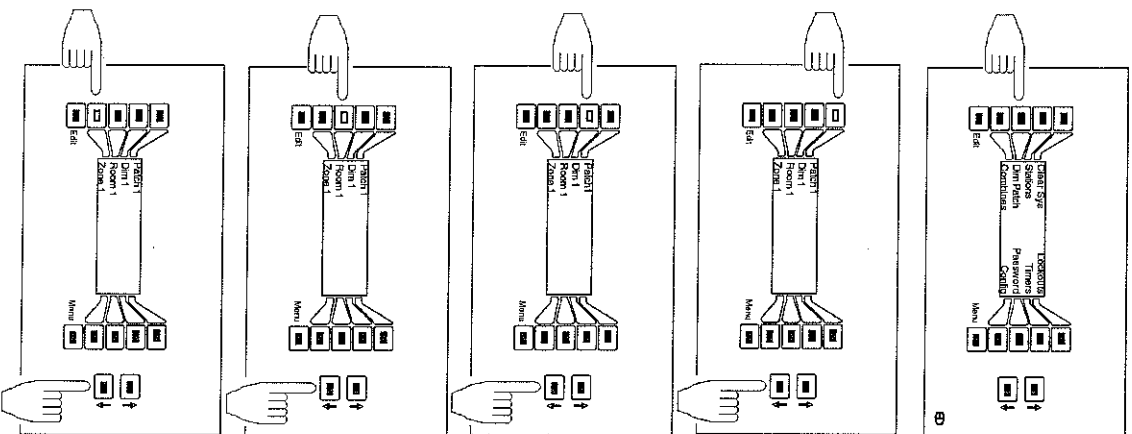

PATCH

NON DIMMING:

For lights that are designed to turn on and off without dimming, the SMART System has a NonDim feature. NonDim dimmers will turn on above 50% and off below 50%.

From the Patch Screen,

Press **Edit**.

Press **NonDim**.

Press **Up** button assign a nondim,
press **Down** button to dim.

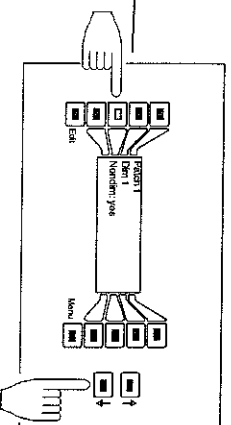

Note: Multiple Dimmers can be assigned to a zone within a room , but multiple zones cannot be assigned to the same dimmer.

COMBINES

OVERVIEW

Combines allow multiple rooms function as one. This scenario is most useful in auditoriums or meeting rooms with adjoining areas. The adjoining areas will either mimic or activate presets in reference to the main area.

OVERLAPPING COMBINE ACTIONS

A combine action can combine from two to eight rooms by a single combine activation switch. If two combine actions are joined with an overlapping of rooms between them, the SMART System will conveniently operate the area as if it were one large combine action.

ACTIVATION

The combine actions can be activated either by a physical switch wired via the backside of the Master Station or through the use of a Remote Device Interface. The Combine Actions are last action events and will take effect on the next preceding execution of a preset within the combined rooms .

To learn more about the RDI turn to page 17.

COMBINES

COMBINE SETUP

From Preset Menu,
To Setup A Combine,
 Press **Menu**, **Main Menu** displays
 Press **Combines**.

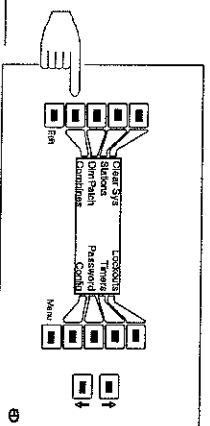

Select a Combine:
 Press **Combine**.
 Use **Up/Down** buttons to select
 a **Combine**.

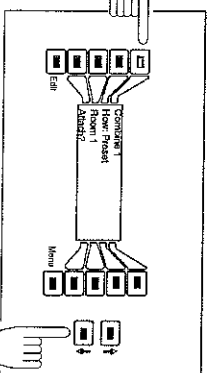

Select Rooms to Combine:
 Press **Room**.
 Use **Up/Down** buttons to select
 one room to combine.
 Press **Attach?**
 Press **Room**.
 Use **Up/Down** buttons to select
 another room to combine.
 Press **Attach?**
 Select and attach another room
 as needed.

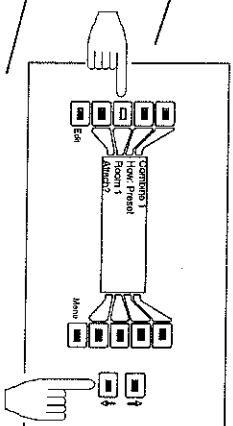

EXAMPLE:
To Combine Rooms 2,3, and 8.

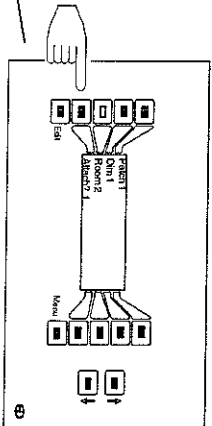

Combine room 2:

Press **Room**.
 Press **Up** button.
 Press **Attach?**

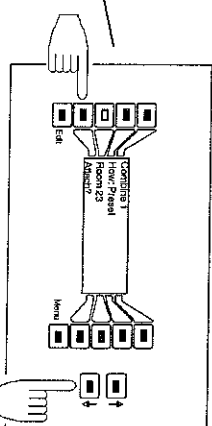

Combine rooms 2 and 3:

Press **Up** button.
 Press **Attach?**

Combine rooms 2, 3, and 8:

Press **Up** button 5 times.
 Press **Attach?**

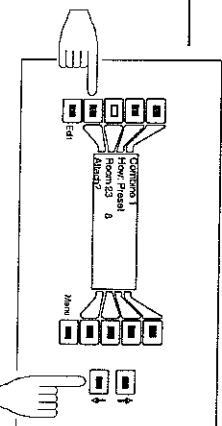

To exit and save, press **Menu**.



COMBINES

HOW?: PRESET VS. ZONE COMBINING

The SMART System can combine rooms in following ways: through preset activation or zone copying. When rooms are combined through presets, the activation of one preset in one room will cause the activation of the same preset number in other rooms. Thus, if Preset 1 was activated in room 1 in a two room scenario, Preset 1 in Room 2 would activate. When rooms are combined through zones, zones levels of one room's preset will follow into other combined rooms. Back to the two room scenario, if Preset 1 was activated in room 1 and zones 1 through 4 are at full for that preset, then zones 1 through 4 in room 2 will go to full. If the two rooms were identical, they would both have the same look.

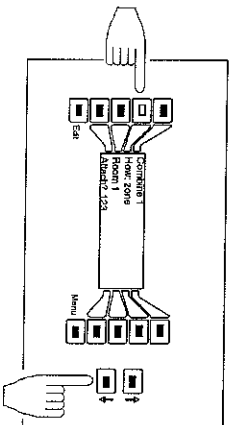

Within Combine Menu, To Designate Zone Combining,

Press **How**:

Press **Up** button for preset combining or press **Down** button for zone combining.

Note: The setting of the combine "How" is a global setting. All combine actions will either be preset or zone.

COMBINES

XGLOBALS

One of the 13 XGlobal presets can replace 1 preset per combine action. The Xglobal Preset will replace only presets that are within the combined rooms. Since they are global presets, they will affect all zones in every room unless they are skipped.

For more on Xglobals turn to page 8.

From the Combine Menu,
To replace a Presets with an XGlobal Preset,
 Press **Edit**.

Select Presets to be replaced:
 Press **Replace Pr.**
 Use **Up/Down** buttons to select preset. To not replace a preset select none.

Select XGlobal Preset:
 Press with **X GPr.**
 Use **Up/Down** buttons to select XGlobal preset. To not replace a preset select none.

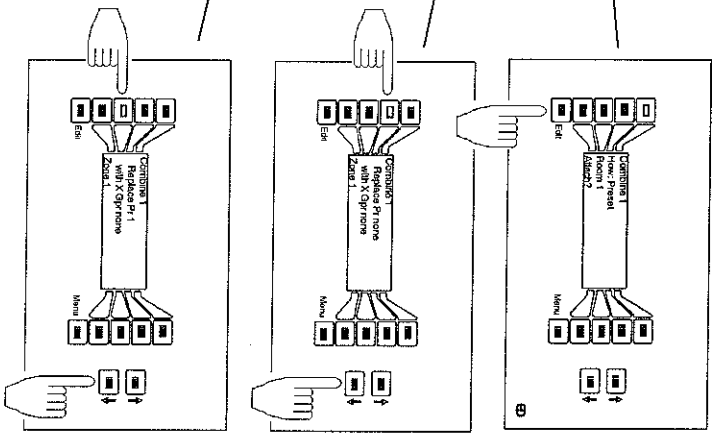

COMBINES

PATCH CHANGING

Each combine action has the ability to switch to a different patch. This is most useful in head/table scenarios where XGlobal substitutions and simple preset/zone combining is not desired.

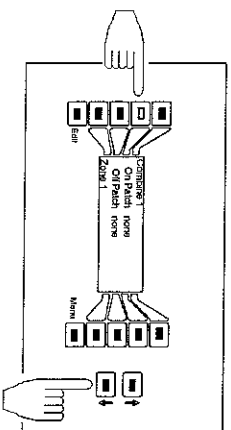

From the Combine Menu,
To Change Patches when in a combine action,

- Press **Edit** twice.
- Press **On Patch**.
- Use **Up/Down** buttons to select the patch page you will use in the combine.
- Select **none** to not change patches when combine action is engaged.

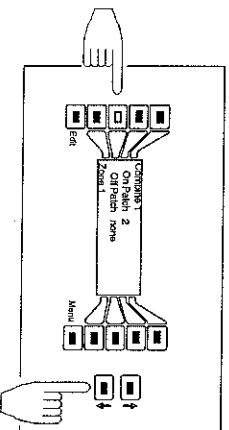

To go to a patch page when a combine action is disengaged.

- Press **Off Patch**.
- Use **Up/Down** buttons to select the patch to go back to after combining. Select **none** to not change patch after combine action is disengaged.

Press **Menu** to go to Preset Menu.

LOCKOUTS

OVERVIEW

The SMART System has 20 lockout actions to lock and unlock stations. All lockout actions can effect the one or multiple stations. One lockout function can lock one station and unlock another. The lockout actions are activated by a preset. The Master Station can override all station lockouts if needed.

SETUP LOCKOUT ACTIONS

From Preset Menu,
To Setup a Lockout Action,
 Press Menu.
 Press Lockouts.

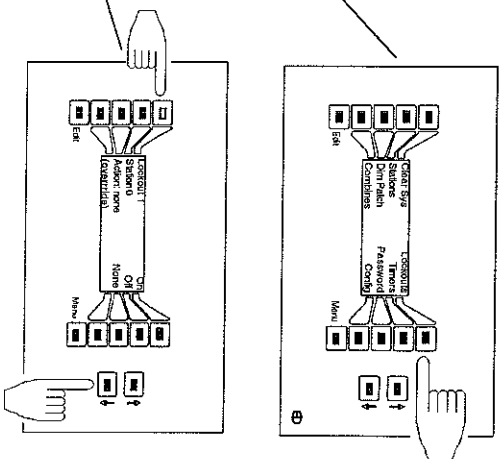

Select a Lockout Action:
 Press Lockout.
 Use Up/Down buttons to select a lockout action.

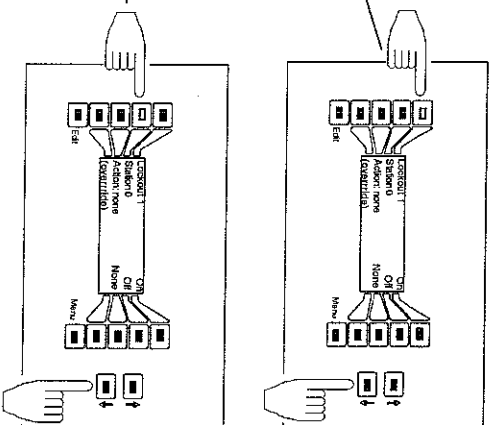

Select a Station:
 Press Station.
 Use Up/Down buttons to select a station (If you forgot your station's address press Menu twice, then Stations, and find your station in one of the 16 slots.)

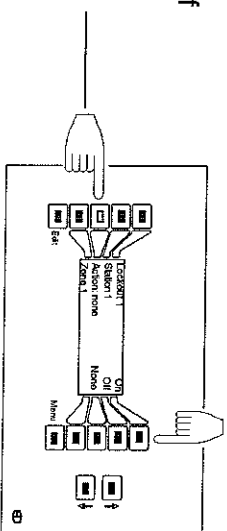

Select the Action for the Lockout Action:
 Press Action.
 Press one of the selections to the right: Select On to lock, Off to unlock, or None to do nothing (none is the default for all stations).

Press Menu to go to Preset Menu.

LOCKOUTS

ASSIGN LOCKOUT ACTIONS

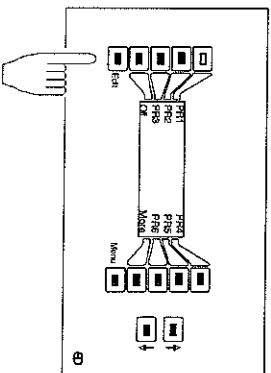

From the Lockout Menu,
To Assign a Lockout Action to a preset,
 Press **Menu**. **Preset Menu** displays.
 Press **Edit** 3 times
 Press **Lockout**.
 Use **Up/Down** buttons to assign the lockout action the preset will activate. **None** means that no lockout actions have been assigned.

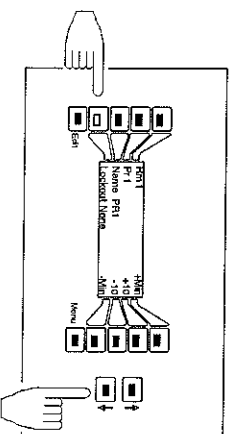

Press **Menu** to go back to Preset Menu.

OVERRIDE LOCKOUT ACTIONS

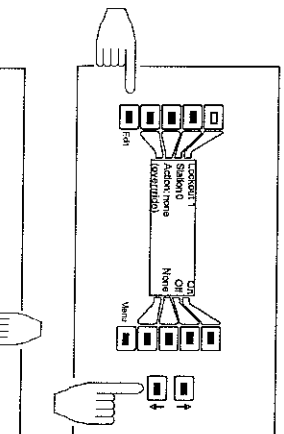

From Preset Menu,
 Press **Menu**. **Main Menu** displays.
 Press **Lockouts**.
 Press **(override)**.
 Press **Status**.
 Press either buttons on the right side to lock or unlock stations. **On** for locked and **Off** for unlocked.

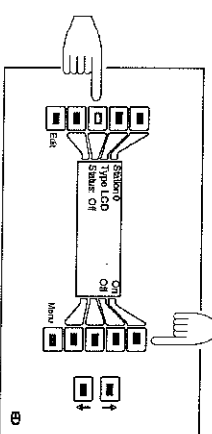

Press **Menu** to go to Preset Menu

LOCKOUTS

EXAMPLE: A ONE PRESET LOCK

For the following example, the SMART System will lock and unlock a 10-Button station in a single room scenario. The system will be setup such that Preset 1 in Room 1 will lock this station. To unlock, an alternate preset on another station within the same room will have to be activated to unlock this station. In this example, the 10-Button station will be on address 0.

TO SETUP:

From Preset Menu,
To Setup a Lockout Action to lock the 10-Button,
Press Menu.
Press Lockouts.

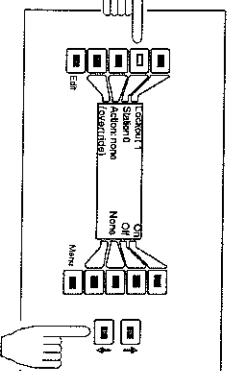
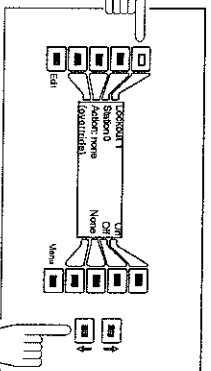
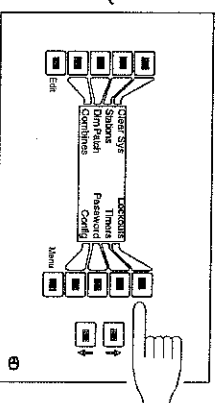

Select Lockout Action 1:
This should be already selected, if not:
Press Lockout.
Use Down button to select lockout action 1.

Select the 10-Button Station:
Press Station.
Use Up/Down buttons to select station 0.

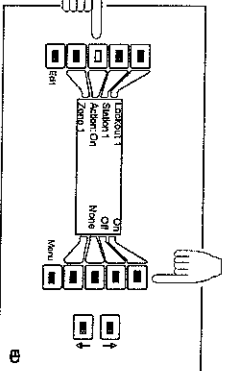

Select Action ON for the Lockout Action:
Press Action.
Press the On selection to the right.

LOCKOUTS

Now Setup a Lockout Action to unlock the 10-Button,

Select Lockout Action 2:

- Press **Lockout**.
- Use **Up** button to select lockout action 2.

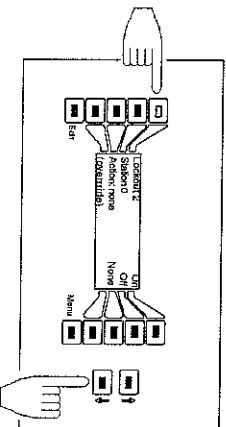

Select the 10-Button Station:

- Press **Station**.
- Use **Up/Down** buttons to select station 0.

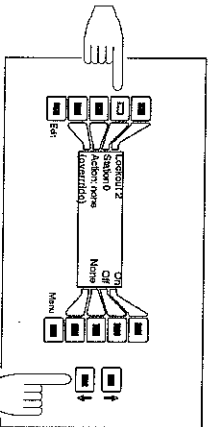

Select Action OFF for the Lockout Action:

- Press **Action**.
- Press the **Off** selection to the right.

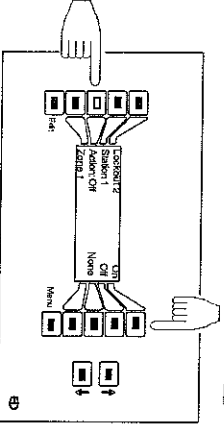

Press **Menu** to go to Preset Menu.

Lockout 1 now must be linked to preset 1 in room 1 for the 10-Button station to get locked. To link Preset 1, Room1 to Lockout 1. Press **Edit** 3 times

If not already selected, select preset 1 in room 1:

- Press **Room**.
- Use **Down** button to select room 1.
- Press **Preset**.
- Use **Down** button to select preset 1.

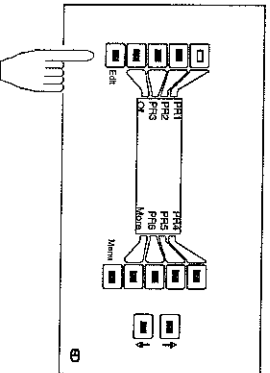

Select Lockout 1:
Press **Lockout**.
Use **Up/Down** buttons to select lockout action 1.

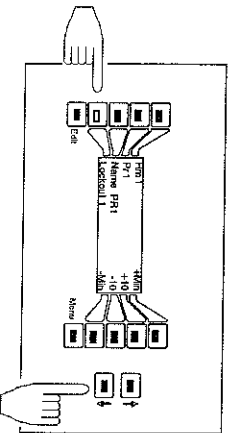

LOCKOUTS

Lockout 2 now must be linked to the other presets to unlock the 10-Button station. To setup Lockout 2 to the other stations:

Select preset 2 in room 1:

Press **Preset**.
Press **Up** button to select preset 1.

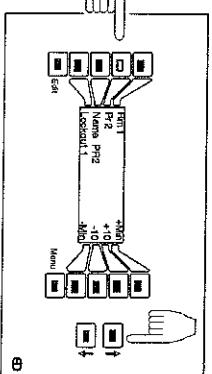

Select Lockout 1:

Press **Lockout**.
Use **Up/Down** buttons to select lockout action 2.

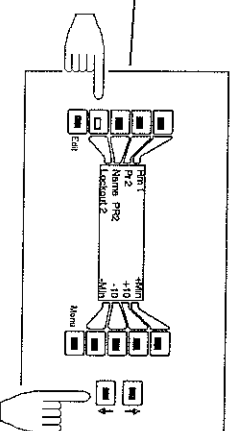

Repeat the same action for presets 3 through 13 (OFF is 13). Now all presets except preset 1 will lock the station. Remember once the station is locked out, it is inoperable and must be unlocked by another station.

EXAMPLE: A ONE PRESET LOCK

For this example, the SMART System will lock and unlock the same 10-Button station in a single room. The system will be setup such that presets located on the left hand side of the controls (presets 1, 2, 3, 7, 8, 9, and OFF) will lock the 10-Button, and presets on the right hand side (presets 4, 5, 6, 10, 11, and 12) will unlock. In this example, the 10-Button station will be on address 0.

TO SETUP:

From Preset Menu,
To Setup a Lockout Action to lock the 10-Button,
Press **Menu**.
Press **Lockouts**.

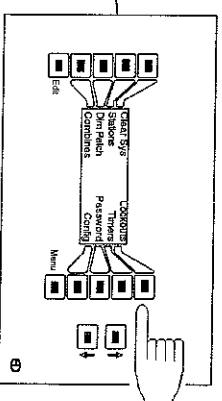

LOCKOUTS

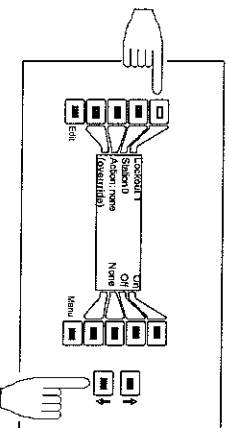

Select Lockout Action 1:
 This should be already selected, if not:
 Press **Lockout**.
 Use **Down** button to select lockout action 1.

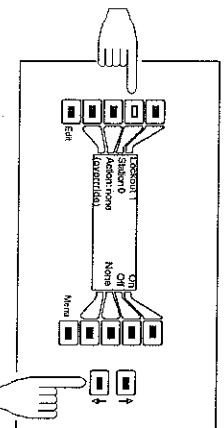

Select the 10-Button Station:
 Press **Station**.
 Use **Up/Down** buttons to select station 0.

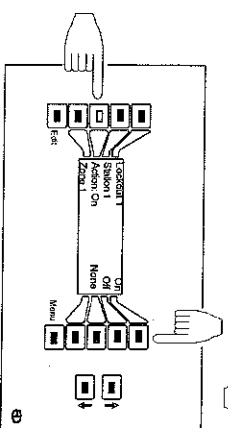

Select Action ON for the Lockout Action:
 Press **Action**.
 Press the **On** selection to the right.

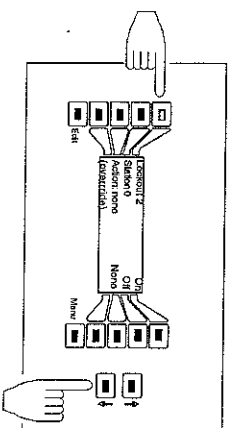

Now Setup a Lockout Action to unlock the 10-Button,

Select Lockout Action 2:
 Press **Lockout**.
 Use **Up** button to select lockout action 2.

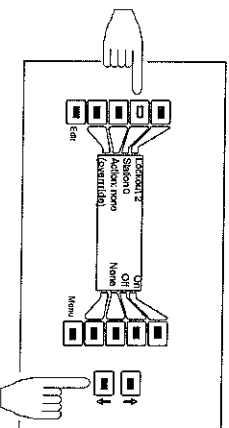

Select the 10-Button Station:
 Press **Station**.
 Use **Up/Down** buttons to select station 0.

Select Action OFF for the Lockout Action:
 Press **Action**.
 Press the **Off** selection to the right.

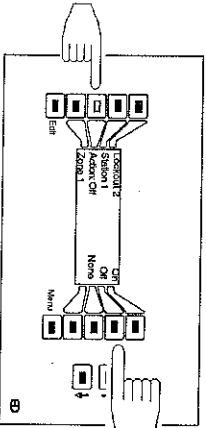

Press **Menu** to go to Preset Menu.

LOCKOUTS

Lockout 1 now must be linked to presets 1, 2, 3, 7, 8, 9, and OFF in room 1 for the 10-Button station to get locked. To link Preset 1, Room 1 to Lockout 1,

Press Edit 3 times _____

If not already selected, select preset 1 in room 1:

- Press **Room**.
- Use Down button to select room 1.
- Press **Preset**.
- Use Down button to select preset 1.

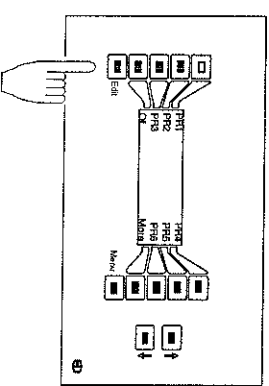

Select Lockout 1: _____
 Press **Lockout**.
 Use Up/Down buttons to select lockout action 1.

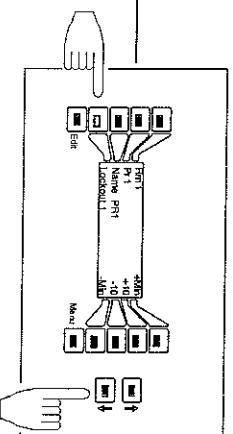

Select Preset 2:
 Press **Preset**.
 Use Up button to select preset 2.

Select Lockout 1: _____
 Press **Lockout**.
 Use Up/Down buttons to select lockout action 1.

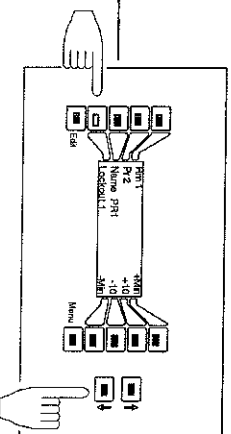

To do Presets 3,7,8,9, and OFF, follow the last two steps. Remember that OFF is preset 13.

LOCKOUTS

Lockout 2 now must be linked to presets 4, 5, 6, 10, 11, and 12 in room 1 for the 10-Button station to get unlocked. To link Preset 4, Room1 to Lockout 2,:

- Press **Edit** 3 times

Select preset 4 in room 1:

- Press **Preset**.
- Use **Up** button to select preset 4.

Select Lockout 2:

- Press **Lockout**.
- Use **Up/Down** buttons to select lockout action 2.

Select Preset 5:

- Press **Preset**.
- Use **Up** button to select preset 5.

Select Lockout 1:

- Press **Lockout**.
- Use **Up/Down** buttons to select lockout action 2.

To do Presets 5,6,10,11, and 12, follow the last two steps.

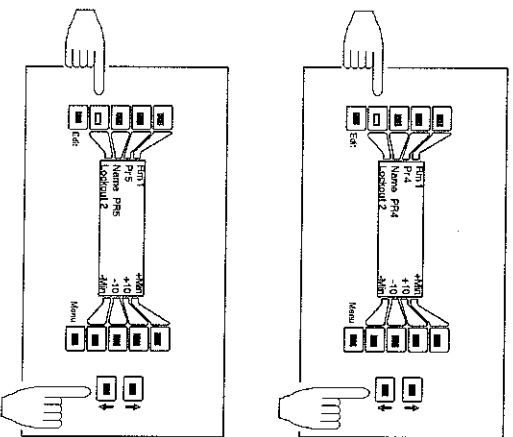

TIMECLOCK

OVERVIEW

The SMART System has 20 timeclock events. Each event can be programmed to activate one preset in one room. Events are setup on a weekly timer and individual events can be programmed from once a week to every day. The operations of the time clock can be turned on and off as needed.

SETUP CLOCK

From Preset Menu,
To Change Clock Time,
Press Menu.
Press Timers, Timer
Menu displays.
Press Edit.

Change the Day:
Press Day.
Use Up/Down buttons to
select day.

Change the Hour:
Press Hour.
Use Up/Down buttons to
select hour. Note: clock is in
24 hours (-1-12PM is 13-24).

Change the Minute:
Press Min.
Use Up/Down buttons to
select minute.
Press Edit to go into Timer Menu.
Press Menu to go to Preset Menu.

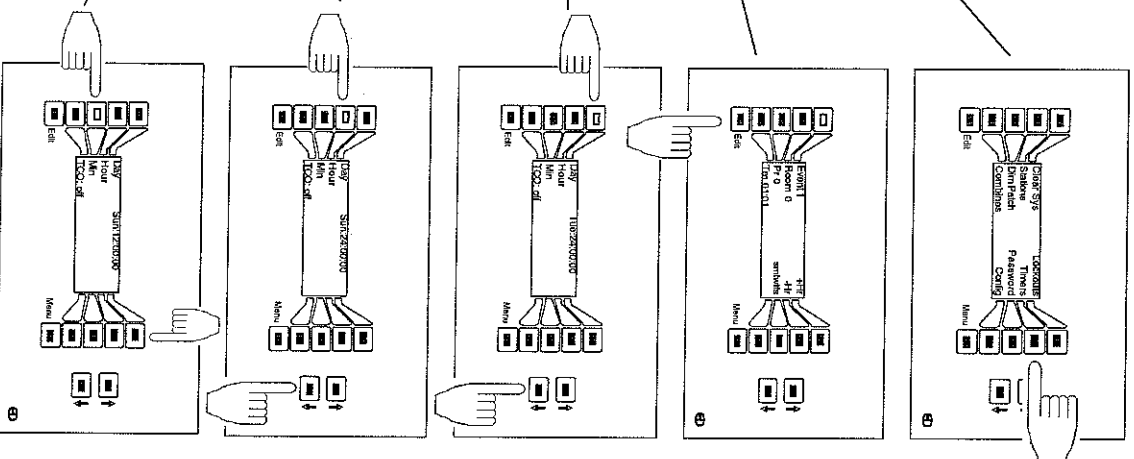

TIMECLOCK

SETUP EVENTS

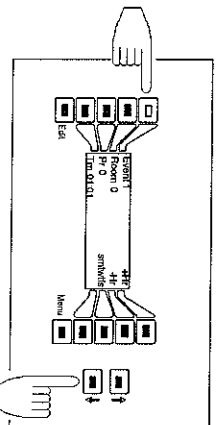

From Timer Menu,
Select an Event:
 Press **Event**.
 Use **Up/Down** buttons to select an event to edit.

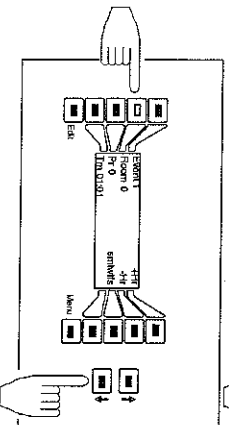

Select the Room Where the Event will Happen:
 Press **Room**.
 Use **Up/Down** buttons to select a room.

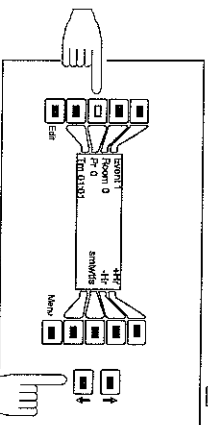

Select a Preset the Event will Activate:
 Press **Preset**.
 Use **Up/Down** buttons to select preset.

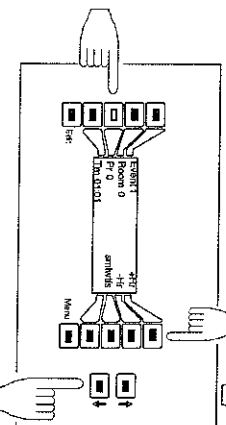

Set the Time to Activate the Event:
 Press **Tm**.
 Use **Up/Down** buttons to change time by minutes or the **+Hr/-Hr** to change by hours. Note: timer is in 24 hours. (1-12PM is 13-24)

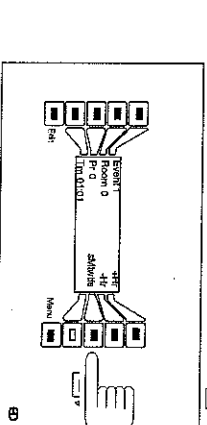

Select the Days That the Event Will Happen:
 Press **3rd** button on the left (**smTWfTs**).
 Highlight the day by uppercasing the day through multiple hits of the **3rd** button on the left. (Ex. **smTWfTs** - Tuesday is highlighted).
 Press the **illuminated** button to select the day.
 Repeat for multiple days.

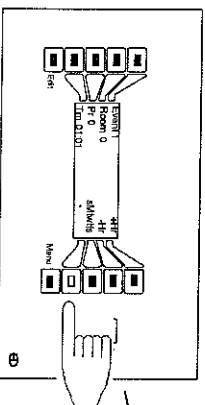

TIMECLOCK

TURNING ON/OFF EVENTS

From Preset Screen,
To Turn On and Off all Events,

- Press **Menu**.
- Press **Timers**. The **Timer Menu** comes up
- Press **Edit**.
- Press **TCO (Time Clock Override)**.
- Press either **Up** button to turn on all the events or **Down** button to turn them off.
- Press **Edit** to return to **Timer Menu**.

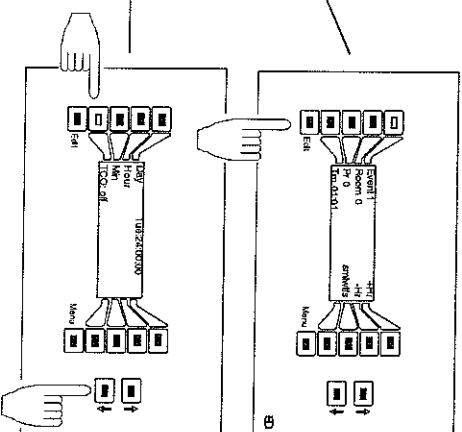

Note: TCO can be changed through the RDI.
See page 18 for more details about RDI functions.

From Timer Menu
To turn off specific events
Select Event:

- Press **Event**.
- Use **Up/Down** buttons to select event.

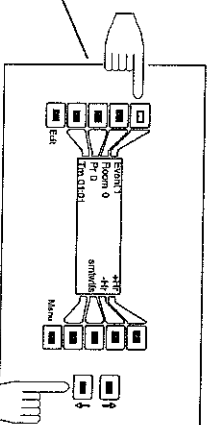

Set Room to 0:

- Press **Room**.
- Use **Down** button to go to 0.

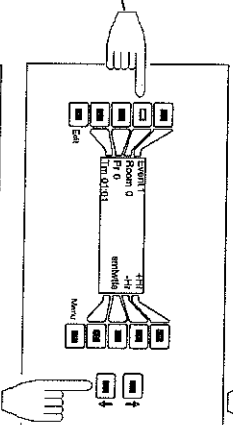

Set Preset to 0:
Press **Preset**
Use **Down** button to go to 0.

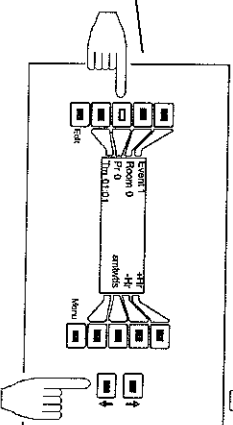

CONFIGURATION SETTINGS

REMOTE EDIT

Allows the user to record live from a station other than the master. This affects edit functions on Sliders and Slave LCDs. If remote edit is set to no, the LCD will not display any Preset editing screens, The record button on the Slider Stations will not work also, except in paging.

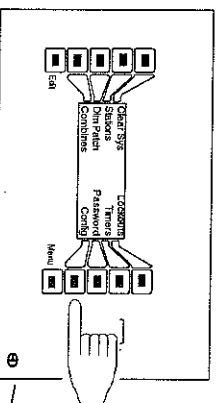

From Preset Screen,
Press **Menu**. Main Menu displays.

Press **Config**.

Press **Remote Edit**.

Press **Up** button for yes or
Down button for no.

PASSWORD

Password Protection can be set on the Master Station such that menus dealing Lockout, Timer, Password, Configuration Settings, Combiner, Dimmer Patches, System Clearing are safeguarded with a password. Presets, still can be edited at the Master and other stations. The default password is four hits on the top left button. To edit the password see page 32.

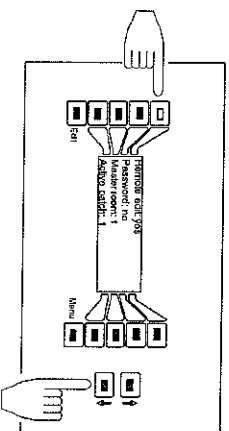

From Preset Screen,

Press **Menu**. Main Menu displays.

Press **Config**

Press **Password on**.

Press **Up** button for yes or
Down button for no.

MASTER ROOM ASSIGNMENT

The Master Room can be assigned any room and does not take up an address.

CONFIGURATION SETTINGS

(master room
continued)

From Preset Screen,
Press **Menu. Main.**
Menu displays.
Press **Config.**
Press **Master room.**
Use **Up/Down** buttons
to select a room.

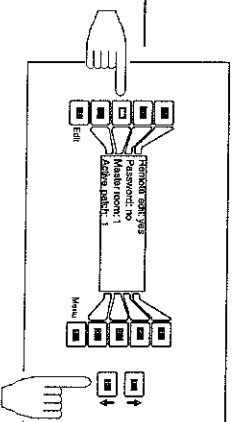

ACTIVATE PATCH

Select one of the 9 patch tables
available on the SMART System to
be active. For more on patching go
to page 19

From Preset Screen,
Press **Menu. Main**
Menu displays.
Press **Config.**
Press **Active Patch.**
Use **Up/Down** buttons
to select a patch.

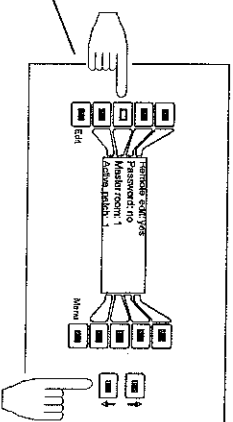

BLACKOUT

The SMART System allows the user
to blackout rooms manually if needed.
This feature can also be set by an RDI
(see pages 18-19)

From Preset Screen,
Press **Menu. Main**
Menu displays.
Press **Config.**
Press **Edit.**
Press **Room.**
Use **Up/Down** buttons
to blackout/unblackout
room.
Press **Blackout.**
Press **Up** button to turn
blackout on and **Down**
to turn off.

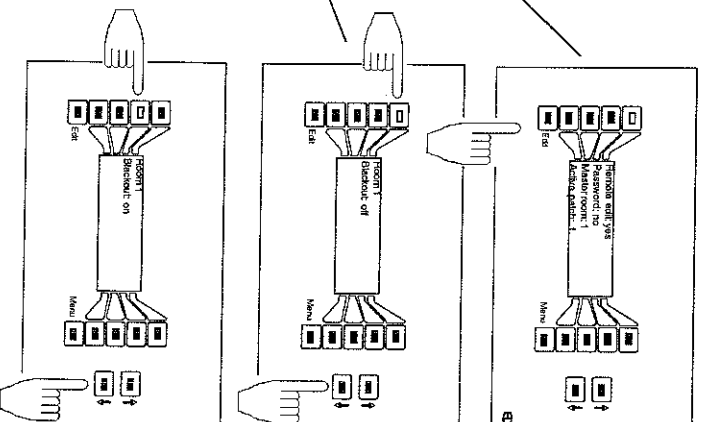

PASSWORDING

CHANGING PASSWORDS

The SMART System uses password protection to prevent unwanted clearing and editing of the system. The default password is four hits in the upper left button on the Master Station. This password can be changed for increased protection. All buttons on the faceplate are accessible to making a new four digit code. **For password enabling, turn to page 32.**

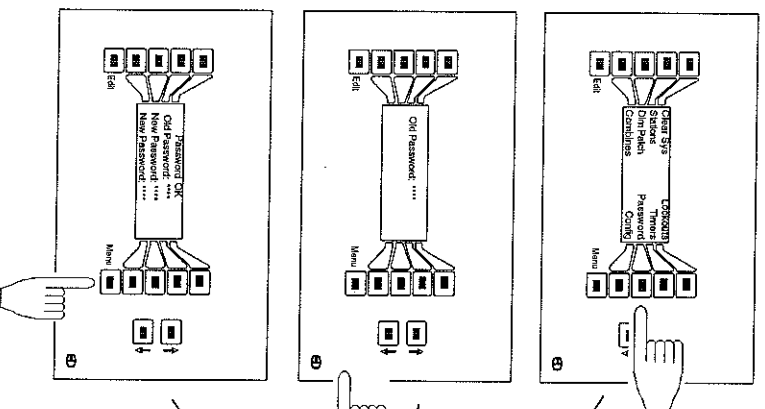

From Preset Screen,

Press **Menu**.

Press **Password**.

Type in Old four digit password.

Type in New password

again.

After OK, press **Menu** to return to Preset Menu.

NOTE: DO NOT TURN THE SMART SYSTEM OFF DURING ANY PART OF PROGRAMMING IN THE PASSWORD.

If inaccurate information is placed in the SMART System, it will return back to the Menu Screen.

CLEARING THE SYSTEM

CLEARING AND SETUP

From the Preset Menu,
Press **Menu**.
Press **Clear Sys.**.

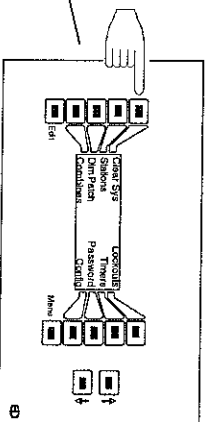

Enter 4-digit password using the 12
keys on the Master Station:

Default password is 4 hits on
the top left button.

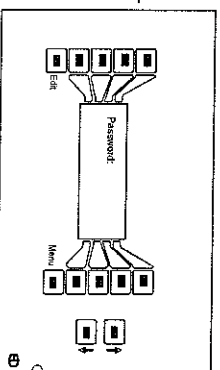

**AFTER THE LAST DIGIT IS PUT IN,
THERE IS NO RETURNING AND
NO OUTSIDE COPY CAN BE
MADE OF THE PROGRAM!**

Good Bye will appear on the Screen,
verifying erasure.

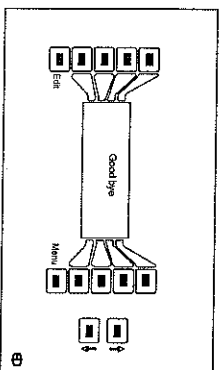

Select Room Size:
Use **Up/Down** buttons to
select the number of rooms.
Press **Menu**.

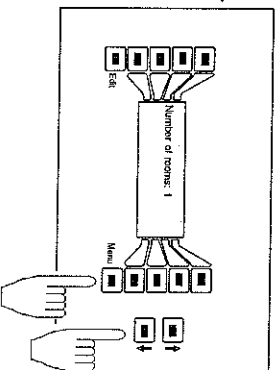

**Select maximum Zone size for each
room:**
Press a room button (**Rm1**,
Rm2, etc.),
Use **Up/Down** buttons to set
the maximum number of zones
for that room. The user can
spread the 100 zone limit
across the number of rooms
selected.
Press **Menu**.

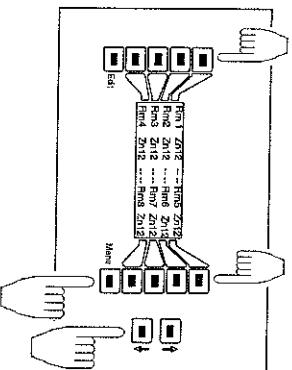

STATION WIRING

Standard cabling: 3 cables

DMX cable: Belden 9842 (1000')
 Power cable: 2 18# AWG (1000')
 LAN cable: Alpha 1133C (1000')

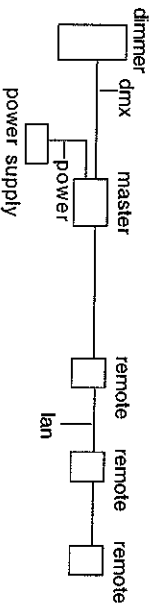

Option 1: 2 cables (both cables total 1000')

DMX, Power cable: Belden 9843
 pair 1 = dmx
 pair 2 = +15/24 (both wires)
 pair 3 = ground (both wires)
 LAN cable: Alpha 1133C

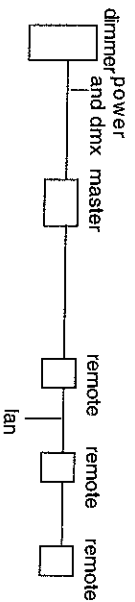

Option 2: 1 cable (500' w/ up to 8 stations, 1000' w/ up to 4 stations)

DMX, Power, LAN cable: Belden 9844;
 pair 1 = dmx
 pair 2 = lan
 pair 3 = +15/24 (both wires)
 pair 4 = ground (both wires)

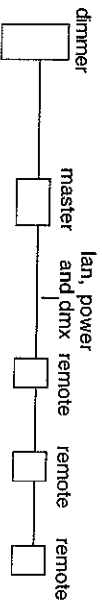

HARDWARE PIECES

OVERVIEW

- 1. Back Circuit Board**
Contains electronics for processing SMART functions.
- 2. Standoffs**
- 3. Front Circuit Board**
Provides the front end for controls.
- 4. Standoffs**
- 5. Subplate**
Plate used for mounting SMART System. Use #6 screw to mount to electrical backbox.
- 6. Faceplate**
Rounded neural design easily matches any decor.
- 7. Mounting Tabs**
Used to secure faceplate to subplate. Latches onto threaded mounting bolts.
- 8. Mounting Bolts**
Secured to faceplate. Latches the faceplate on via the mounting tabs.

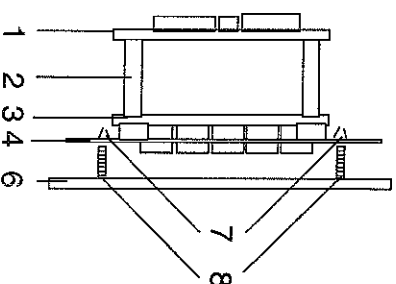

REMOVAL OF FACEPLATE

Work around area between faceplate and subplate with a flathead screwdriver, pulling forward. This will work the mounting bolts from the mounting tabs. Over time, the tabs will wear out, if done repeatedly. If the tabs become loose, simply squeeze them with needle-nose pliers. If the tabs become worn out or malfunctions, please contact the factory or a nearby dealer for service.

