

ACCLAIM LED PLE

Date: _____

Type: _____

Firm Name: _____

Project: _____

The Strand Acclaim LED Profile Light Engine (PLE) brings the innovation that made Acclaim ellipsoidals an industry standard for a generation in a full color LED light engine that works with Strand SPX lenses. This 500 W/650 W-equivalent profile light engine is perfect for small to medium theatres, houses of worship, and education environments, and offers exceptional output with consistent color mixing to the Acclaim LED Zoomspot for applications where a longer throw or wider spread is needed. Because the Acclaim LED PLE works with the industry-standard SPX lens system, the wide range of beam angles available ensures there is lens for any application. With the onboard four-blade manual shutter system, the Acclaim PLE offers superior control to shape the light how you want it. Thanks to the optional size B metal gobo holder, designers can project depth and texture on stage, using the angle adjustment and manual focus to get the look just right. For applications where a low trim height is a challenge, the adjustable yoke allows the fixture to be positioned closer to the suspension point to give more headroom. The Acclaim LED PLE is available in black or white.

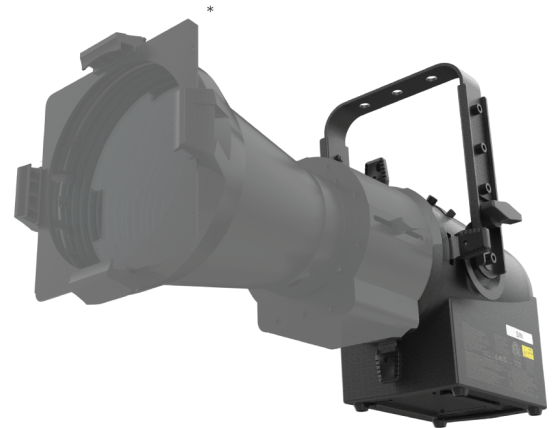

*shown with optional lens tube

- 500 W/650 W-equivalent LED profile engine from Strand – cost effective profile from the original name in theatrical lighting.
- Supports Strand SPX lens system – works perfectly with industry standard lens system with a wide range of available beam angles.
- Four-blade manual shutter system – superior control to position light exactly where you need it.
- Optional angle-adjusting size B metal gobo holder – add depth and texture using industry-standard gobos. Easily adjust gobo angle within holder to get the perfect look.

- Adjustable yoke – mount fixture where you want it even when headroom is limited.
- Custom LED light source and RGBL color mixing system – consistent output and color mixing with the entire Acclaim LED Series.
- Available in black or white – the perfect body color for your application.

For detailed product information, please refer to the Product Guide at <https://www.vari-lite.com/global/products/acclaim-led-ple>

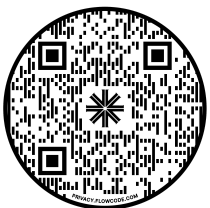

VARI***LITE**

Specifications

Due to continuous improvements and innovations, specifications may change without notice.

Source

LED	Multichromatic Light Engine - RGBL
Source Max Power Consumption	150 W
LED Refresh Rate	500 Hz to 4000 Hz
Dimming	Electronic 8-bit / 16-bit
Dimmer Curves	Square Law (Default), Linear, S -Curve
Strobe Speed	0 - 30Hz

Optical Performance

Output Lumens	Engine only - 8,500
CRI RA	7100 K - 85 5600 K - 84 3200 K - 84
Tm30	7100 K - Rf 77 / Rg 102 5600 K - Rf 78 / Rg 109 3200 K - Rf 78 / Rg 109
CQS	7100 K - 92
TLCI	7100 K - 73 5600 K - 73 3200 K - 70

Color System

Color Mixing	RGBL
Color Mixing Control	Open Source
Color Calibration	Selectable On/Off

Imaging

Shutter	4 blade manual framing shutters
---------	---------------------------------

Electrical

Max output Power Consumption	170 W
Power Connection	TrueOne Compatible - In / Thru Power cable not included - input connector only
Input Voltage	100–240 VAC, 50 / 60 Hz
Standby Power	8.8 W

Data

Supported Protocols	DMX512-A (RDM)
DMX Modes	
16-Bit	11 Channels
8-Bit	8 Channels
Data Connections	5 - Pin XLR Input and Thru
Manual Preset Mode	Advanced Feature local control

Noise Level / Fan Control (Base Level 21 dB @ 1 m (3.3 ft))

Standard Mode	42.8 dB
Studio Mode	35.5 dB
Whisper Mode	33.2 dB
Fan Mode	Continuous (On) / Auto Ramping
Fan Level Preset	Standard, Studio, Whisper
Cooling System Type	Hybrid sealed liquid and forced air system

Mounting

Yoke	Double clutch locking yoke >270° Swivel Yoke M12 (1/2") Centre hole
Fixture mounting/Hanging orientation	Hanging - Floor - Side
Secondary Safety Wire Point	1 x Safety point located on rear of fixture housing Safety Wire not included

Dimensions

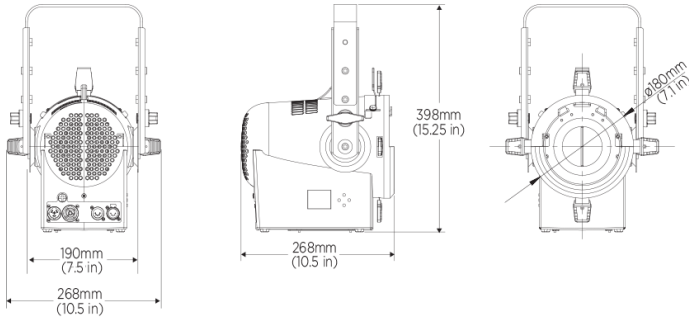

STRAND PLT SERIES	ORDER CODE
PLT 10° lens tube black	64010-002
PLT 10° lens tube white	64010-102
PLT 14° lens tube black	64010-003
PLT 14° lens tube white	64010-103
PLT 19° lens tube black	64010-004
PLT 19° lens tube white	64010-104
PLT 26° lens tube black	64010-005
PLT 26° lens tube white	64010-105
PLT 36° lens tube black	64010-006
PLT 36° lens tube white	64010-106
PLT 5° lens tube black	64010-001
PLT 5° lens tube white	64010-101
PLT 50° lens tube black	64010-007
PLT 50° lens tube white	64010-107
PLT 70° lens tube black	64010-008
PLT 70° lens tube white	64010-108
STRAND SPX ZOOM SERIES	ORDER CODE
25°-50° zoomspot lens tube black	SPX2550LT
15°-35° zoomspot lens tube black	SPX1535LT
STRAND SPX FIXED	ORDER CODE
14° fixed beam lens tube black	SPX14LT
19° fixed beam lens tube black	SPX19LT
26° fixed beam lens tube black	SPX26LT
36° fixed beam lens tube black	SPX36LT
50° fixed beam lens tube black	SPX50LT
STRAND LENS HOLDERS/ADAPTERS	ORDER CODE
PLT FIXED LENS, 4 - Lug lens tube adapter, for use with ACCLAIM PLE, and LEKO LED Light sources, Black	64010-012
PLT FIXED LENS, 4 - Lug lens tube adapter, for use with ACCLAIM PLE, and LEKO LED Light sources, White	64010-112
Universal tube adapter black	PLPF4ULTA

Physical

Construction	Superstructure made of Aluminum, and steel metal plates, Covers self-extinguishing fire retardant ABS PC (V0 class)
IP Rating	IP20
Standard Finish	Black, White
Dimensions	190 x 283 x 268 mm (8.0 x 11.0 x 11.0 in)
Dimension (w/ yoke)	398 x 268 x 268 mm (15.0 x 11.0 x 11.0 in)
Fixture Weight	6.0 kg (13.0 lb)
Operating Temperature	-10-40°C (14-104°F)

Certification and Safety

Approbations
ETL (UL & CSA)CB/IECEE Scheme for CE-LVD, FCC, ICES, RCM, CE-EMC, UKCA, RoHS, ISO 9001

Gobo and Effect Wheels

Gobo Gate	B size (holder optional accessory)
Gobo Size	B

Luminaire and Accessories

Product type	Order Code
ACCLAIM LED PLE, Black	64511-003
ACCLAIM LED PLE, 150W Multichromatic Light Engine - RGBL, c/w Power input connector, Black	
ACCLAIM LED PLE, White	64511-103
ACCLAIM LED PLE, 150W Multichromatic Light Engine - RGBL, c/w Power input connector, White	
Accessories	
Acclaim LED B Size gobo holder	64511-012
ACCLAIM ZOOMSPOT/PLE, B Size Adjustable Gobo Holder - Metal or Glass images ,	
Acclaim LED IRIS	64511-013
ACCLAIM ZOOMSPOT/PLE, Iris	



© 2023 Signify Holding. All rights reserved. All trademarks are owned by Signify Holding or their respective owners. The information provided herein is subject to change, without notice. Signify does not give any representation or warranty as to the accuracy or completeness of the information included herein and shall not be liable for any action in reliance thereon. The information presented in this document is not intended as any commercial offer and does not form part of any quotation or contract, unless otherwise agreed by Signify. Data subject to change.