

Showline

SL NITRO
510C

RGB & W LED Strobe Luminaire



SL NITRO 510C RGB & W LED Strobe Luminaire

INSTALLATION & USER'S GUIDE

The material in this manual is for information purposes only and is subject to change without notice. Showline assumes no responsibility for any errors or omissions which may appear in this manual. For comments and suggestions regarding corrections and/or updates to this manual, please contact your nearest Showline office.

El contenido de este manual es solamente para información y está sujeto a cambios sin previo aviso. Showline no asume responsabilidad por errores o omisiones que puedan aparecer. Cualquier comentario, sugerencia o corrección con respecto a este manual, favor de dirigirlo a la oficina de Showline más cercana.

Der Inhalt dieses Handbuches ist nur für Informationszwecke gedacht, Änderungen sind vorbehalten. Showline uebernimmt keine Verantwortung für Fehler oder Irrtuemer, die in diesem Handbuch auftreten. Für Bemerkungen und Verbesserungsvorschlaege oder Vorschlaege in Bezug auf Korrekturen und/oder Aktualisierungen in diesem Handbuch, moechten wir Sie bitten, Kontakt mit der naechsten Showline-Niederlassung aufzunehmen.

Le matériel décrit dans ce manuel est pour information seulement et est sujet à changements sans préavis. La compagnie Showline n'assume aucune responsabilité sur toute erreur ou omission inscrite dans ce manuel. Pour tous commentaires ou suggestions concernant des corrections et/ou les mises à jour de ce manuel, veuillez s'il vous plait contacter le bureau de Showline le plus proche.

Note: Information contained in this document may not be duplicated in full or in part by any person without prior written approval of Showline. Its sole purpose is to provide the user with conceptual information on the equipment mentioned. The use of this document for all other purposes is specifically prohibited.

	INTENSE STROBE LIGHT WARNING!
	<ul style="list-style-type: none">• Strobe lights are known to trigger epileptic seizures in persons who are photosensitive to intense flashing lights.• Do not operate the fixture near stairways or in small confined spaces.• Avoid extended periods of continuous flashing, particularly at frequencies of 10 to 20 flashes per second.• Owners, users, and facilities using this luminaire should adhere to all local and national requirements of posting warning signs for strobe light use and strobe light effects. This posted warning should be available and visible to anyone attending or performing when the luminaire is in use.

Document Number: **SL NITRO 510C LED STROBE Luminaires Users**

Version as of: **08 April 2014**

SL NITRO 510C LED STROBE Luminaire Installation & User's Manual

IMPORTANT INFORMATION

Warnings and Notices

When using electrical equipment, basic safety precautions should always be followed including the following:



- a. **READ AND FOLLOW ALL SAFETY INSTRUCTIONS.**
- b. Do not use outdoors.
- c. Do not mount near gas or electric heaters.
- d. Equipment should be mounted in locations and at heights where it will not readily be subjected to tampering by unauthorized personnel.
- e. The use of accessory equipment not recommended by the manufacturer may cause an unsafe condition.
- f. Do not use this equipment for other than intended use.
- g. Refer service to qualified personnel.

SAVE THESE INSTRUCTIONS.



WARNING: You must have access to a main circuit breaker or other power disconnect device before installing any wiring. Be sure that power is disconnected by removing fuses or turning the main circuit breaker off before installation. Installing the device with power on may expose you to dangerous voltages and damage the device. A qualified electrician must perform this installation.

WARNING: Refer to National Electrical Code® and local codes for cable specifications. Failure to use proper cable can result in damage to equipment or danger to personnel.

WARNING: This equipment is intended for installation in accordance with the National Electric Code® and local regulations. It is also intended for installation in indoor applications only. Before any electrical work is performed, disconnect power at the circuit breaker or remove the fuse to avoid shock or damage to the control. It is recommended that a qualified electrician perform this installation.

Additional Resources for DMX512

For more information on installing DMX512 control systems, the following publication is available for purchase from the United States Institute for Theatre Technology (USITT), "Recommended Practice for DMX512: A Guide for Users and Installers, 2nd edition" (ISBN: 9780955703522). USITT Contact Information:

USITT
315 South Crouse Avenue, Suite 200
Syracuse, NY 13210-1844
Phone: 1.800.938.7488 or 1.315.463.6463
www.usitt.org

Showline Limited Two-Year Warranty

Showline offers a two-year limited warranty of its luminaires against defects in materials or workmanship from the date of delivery. A copy of Showline two-year limited warranty containing specific terms and conditions can be obtained by contacting your local Showline office.

TABLE OF CONTENTS

Showline Offices.....	Inside Front Cover
IMPORTANT INFORMATION	
Warnings and Notices.....	1
Additional Resources for DMX512.....	1
Showline Limited Two-Year Warranty.....	1
TABLE OF CONTENTS	
PREFACE	
About this Manual.....	4
Included Items.....	4
Accessories.....	4
SL NITRO 510C LED STROBE Luminaire Power Input Cables (North American Models Only).....	4
SL NITRO 510C LED STROBE Luminaire Accessories.....	4
SL NITRO 510C LED STROBE LUMINAIRE OVERVIEW	
SL NITRO 510C LED STROBE Luminaire Components.....	5
Major Luminaire Components.....	5
LCD Display / Menu System.....	6
INSTALLATION AND SET UP	
Power Requirements.....	7
AC Power Operation.....	7
Connecting Power.....	8
Connecting SL NITRO 510C LED STROBE Luminaires to AC Power.....	8
Connecting to the DMX512 Network.....	9
Mounting Luminaire.....	9
Connecting & Mounting Multiple Luminaires.....	10
Connecting Luminaires Top-to-Bottom.....	11
Connecting Luminaires Side-to-Side.....	12
Mounting SL NITRO 510C LED STROBE Luminaire with Other Luminaires.....	12
Connecting Combined Luminaires Top-to-Bottom.....	13
Connecting Combined Luminaires Side-to-Side.....	15
OPERATION AND PROGRAMMING	
LCD Display and Menu System.....	16
LCD Display and Menu System Operation.....	16
SL NITRO 510C LED STROBE Luminaire Main Menu Options.....	17
Presets.....	17
Recalling or Editing Presets.....	17
Effects.....	18
Editing User Chases.....	18
Settings/Security.....	18
Settings/General.....	19
Settings/Factory Default.....	19
Settings/DMX.....	19
Settings/Display.....	20
Lock Fixture.....	20
Password (PassPIN).....	20
Status.....	20
Quick Selection Buttons.....	21
DMX Address.....	21
Harmonize Color Calibration.....	21
Dimming Curve Selection.....	22
Master / Slave Operational Mode.....	23
DMX CONTROL	
RGB & W Operation.....	24
DMX Maps.....	24
RGBW Full Mode.....	24
RGBW Full Mode (Zones).....	28

RGBW Expanded Mode 29

RGBW Expanded Mode (Zones)..... 32

RGBW 16-Bit Mode..... 33

RGBW 16-Bit Mode (Zones) 36

RGBW 8-Bit Mode..... 37

RGBW 8-Bit Mode (Zones) 40

6-Channel Mode 41

Mapping 16-Bit Mode 44

SL NITRO 510C LED Groups/Zones 45

Strobe Rate DMX Timing Detail 46

Strobe Duration DMX Timing Detail 47

SL NITRO 510C LED STROBE Luminaire RDM Parameter IDs 48

CLEANING AND CARE

Special Cleaning and Care Instructions 52

Front Lens Cleaning..... 52

Service and Maintenance 52

TECHNICAL SPECIFICATIONS

SL NITRO 510C LED STROBE Luminaire Operational Specifications..... 53

SL NITRO 510C LED STROBE Luminaire Dimensions 53

PREFACE

1. About this Manual

The document provides installation and operation instructions for the following products:

- SL NITRO 510C LED STROBE Luminaire

Please read all instructions before installing or using this product. *Retain this manual for future reference.* Additional product information and descriptions may be found on the product specification sheet.

Note: The SL NITRO 510C LED STROBE Luminaire is universal voltage 100 to 240 VAC (auto-ranging).

2. Included Items

Each SL NITRO 510C LED STROBE Luminaire includes the following items:

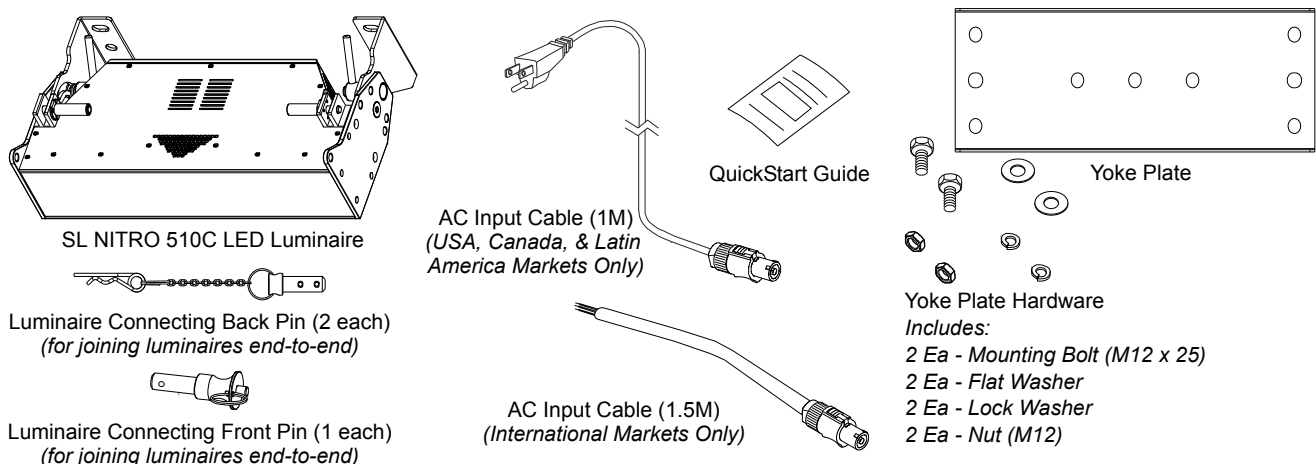

Figure 1: Included Items

3. Accessories

SL NITRO 510C LED STROBE Luminaire Power Input Cables (North American Models Only)

Part Number	Description
PC1BE	SL NITRO 510C LED STROBE Luminaire AC Power Input Cable (39 inches / 1 meter), Powercon with Bare End* (*Note, user supplies and installs own AC input connector)
PC1GP	SL NITRO 510C LED STROBE Luminaire AC Power Input Cable (39 inches / 1 meter), Powercon with Stagepin Connector
PC1GTL	SL NITRO 510C LED STROBE Luminaire AC Power Input Cable (39 inches / 1 meter), Powercon with Twistlock Connector
PC1GR	SL NITRO 510C LED STROBE Luminaire AC Power Input Cable (39 inches / 1 meter), Powercon with Edison Connector
PC3BE	SL NITRO 510C LED STROBE Luminaire AC Power Input Cable (9.8 Feet / 3 meter), Powercon with Bare End* (*Note, user supplies and installs own AC input connector)
PC8BE	SL NITRO 510C LED STROBE Luminaire AC Power Input Cable (26 Feet / 8 meter), Powercon with Bare End* (*Note, user supplies and installs own AC input connector)
PC8GR	SL NITRO 510C LED STROBE Luminaire AC Power Input Cable (26 Feet / 8 meter), Powercon with Edison Connector

SL NITRO 510C LED STROBE Luminaire Accessories

Part Number	Description
MC	Mega Claw, Black, Anodized
SC	Molded Yoke C-Clamp
HC	Light Weight Half Coupler
82003	Safety Cable
SLPIN1	Luminaire Connecting Front Pin (North American Models Only)
SLPIN2	Luminaire Connecting Back Pin (North American Models Only)

SL NITRO 510C LED STROBE LUMINAIRE OVERVIEW

1. SL NITRO 510C LED STROBE Luminaire Components

Major Luminaire Components

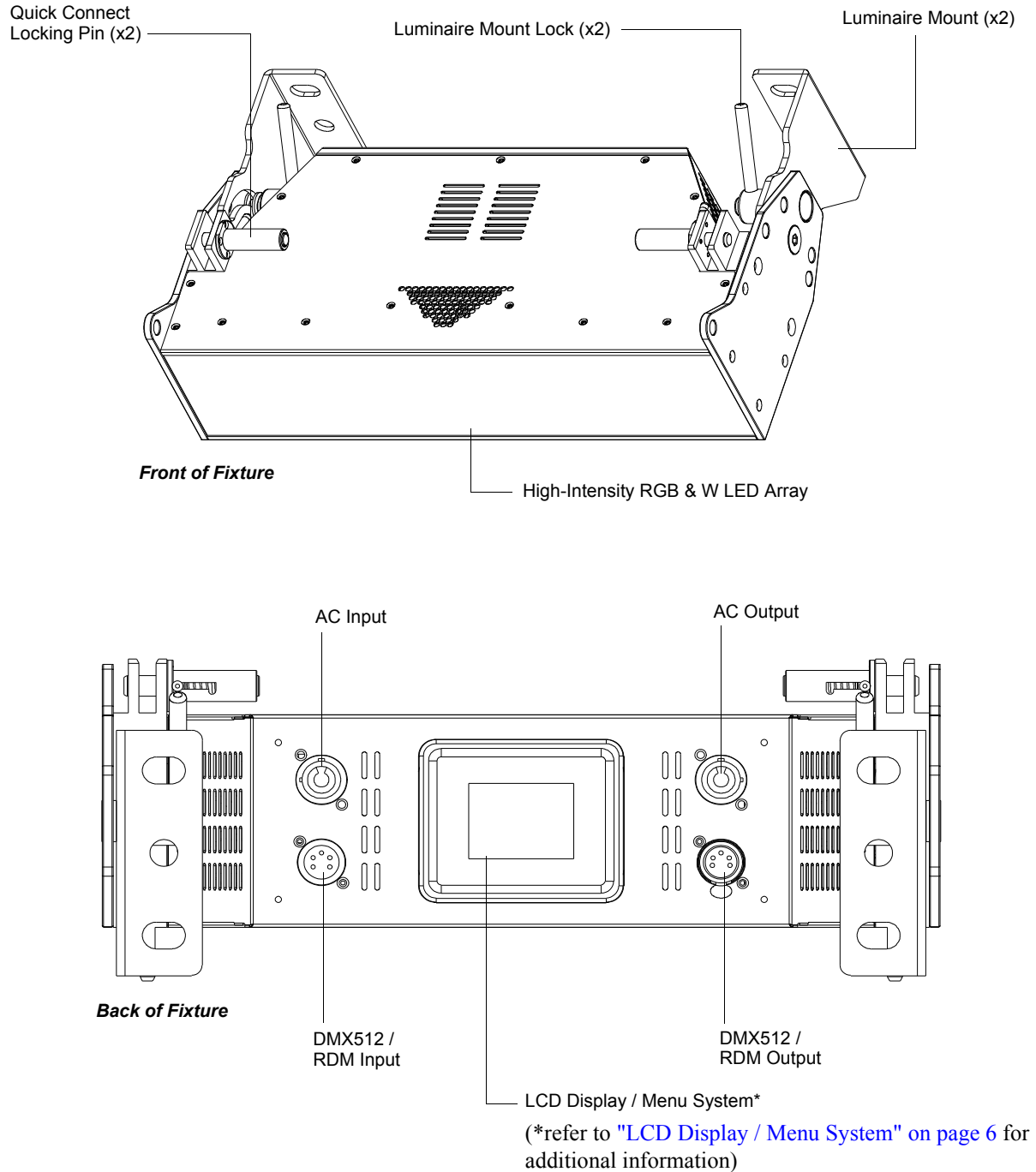
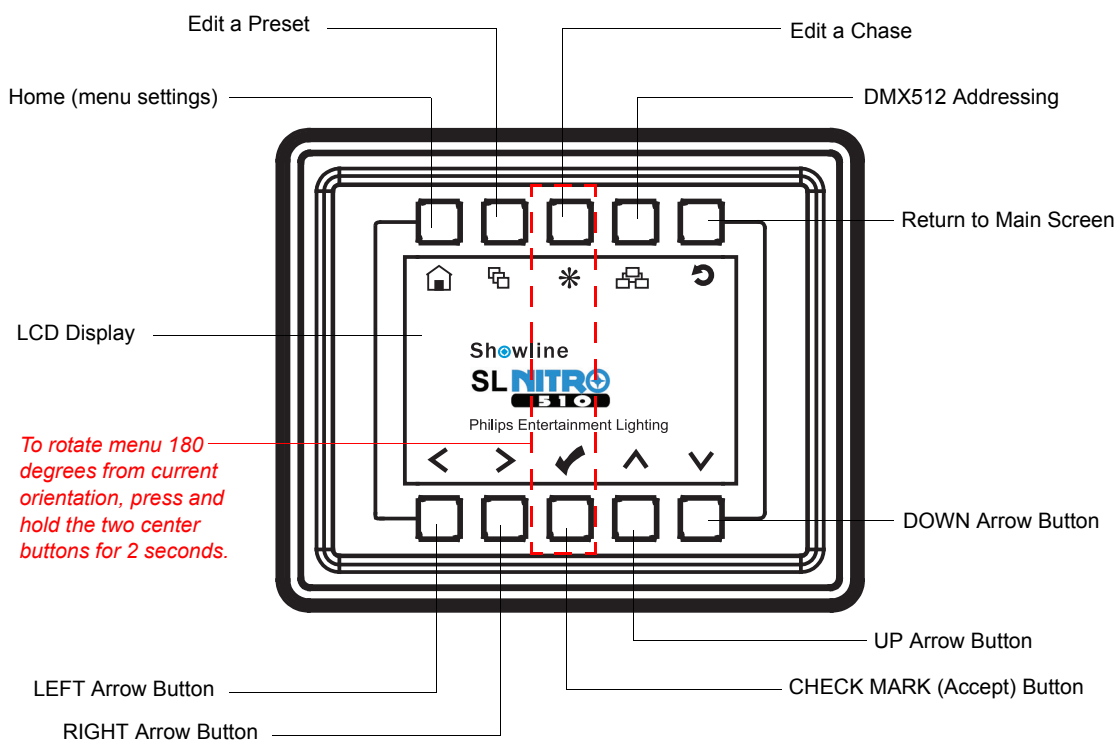

Figure 2: SL NITRO 510C LED STROBE Luminaire Components

LCD Display / Menu System



NOTE: Menu rotates with orientation of luminaire and menu buttons are always in the same position (with rotation of menu)

Figure 3: LCD Display & Menu System

Note: For Menu operation and programming details, refer to "LCD Display and Menu System" on page 16.

INSTALLATION AND SET UP

1. Power Requirements

The SL NITRO 510C LED STROBE Luminaire operates on AC input voltages from 100 to 240 VAC.



WARNING! This unit does not contain an ON/OFF switch. Always disconnect power input cable to completely remove power from unit when not in use.

AC Power Operation

When connected to an AC source, the unit operates on 100 to 240 volts AC (+/- 10%, auto-ranging). The luminaire contains an auto-ranging power supply. Each luminaire can draw up to 360 Watts.



WARNING! Maximum amount of units that may be daisy-chained is (A) 5 units 100VAC (20 Amps) or (B) 13 units 240VAC (20 Amps). Refer to [Table 1](#) for detailed information at various voltages.

Note: For wiring of AC input connector, refer to "[Connecting SL NITRO 510C LED STROBE Luminaires to AC Power](#)" on page 8.

Table 1: SL NITRO 510C LED STROBE Luminaire Voltage vs. Current

Voltage (AC)	Total Current (A)	Maximum number of units that can be linked together*	Voltage (AC)	Total Current (A)	Maximum number of units that can be linked together*
100	3.60	5	180	2.00	10
110	3.27	6	190	1.89	10
120	3.00	6	200	1.80	11
130	2.77	7	210	1.72	11
140	2.57	7	220	1.64	12
150	2.40	8	230	1.57	12
160	2.25	8	240	1.50	13
170	2.12	9			



WARNING! *These figures are based on the Maximum Allowable Input Current of 20 Amps (and the maximum power supply limit of 360 Watts). **Do not overload circuits!**



IMPORTANT AC POWER CONNECTION NOTES:

- When using the daisy-chain connection method, **ONLY** connect SL NITRO 510C LED STROBE Luminaires to AC Output Connection of SL NITRO 510C LED STROBE Luminaires. **DO NOT CONNECT OTHER TYPES OF LUMINAIRES OR DEVICES!**
- Use only use approved cable types.
- Do not overload circuits!
- Do not connect SL NITRO 510C LED STROBE Luminaires to dimmed circuits.
- The **MAXIMUM** allowable number of SL NITRO 510C LED STROBE Luminaires which can be 'daisy-chained' on one power feed are listed in [Table 1](#), above. **DO NOT EXCEED!**

2. Connecting Power

Units can be powered in one of two ways:

- Direct connection to a AC power source using an AC input cable. For wiring of AC input connector, refer to "[Connecting SL NITRO 510C LED STROBE Luminaires to AC Power](#)" on page 8.
- Connection from the AC output of another SL NITRO 510C LED STROBE Luminaire. When using this method, it is very important not to connect any other type of equipment device.



WARNING! Only connect other SL NITRO 510C LED STROBE Luminaires to the AC Output (Thru) connector of a SL NITRO 510C LED STROBE Luminaire.

Connecting SL NITRO 510C LED STROBE Luminaires to AC Power

If the unit is supplied with an AC input cable without an input connector installed. The input connector is a user-supplied accessory.

Table 2 on page 8 describes how to connect power to your SL NITRO 510C LED STROBE Luminaire. Field wiring of the SL NITRO 510C LED STROBE Luminaire is straight forward. A total of 3 wires/conductors is supplied from the unit. The following wiring scheme is used:

Table 2: SL NITRO 510C LED STROBE Luminaire (IP20 Rated Models) AC Input Connections

Wire Color	Purpose
Brown	Main / Line (100 to 240VAC)
Blue	Neutral
Green/Yellow	Ground (Earth)



CAUTION: In the event the supplied AC input cable (international markets - outside North America) OR AC input connector (North American markets) is damaged, they must be replaced with an approved replacement through your Authorized Showline Dealer or Service Center.

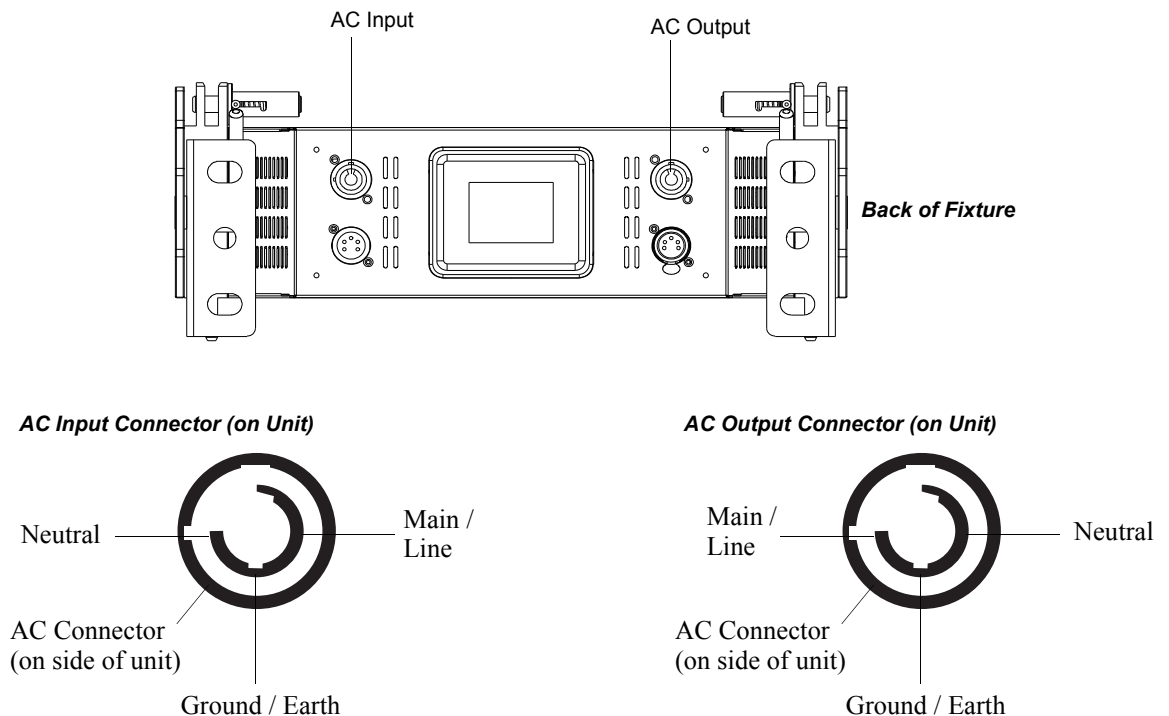

Figure 4: SL NITRO 510C LED STROBE Luminaire AC Input & Output Connections

3. Connecting to the DMX512 Network

Basic DMX512 installation consists of connecting multiple SL NITRO 510C LED STROBE Luminaires together (up to 32 luminaires) in "daisy-chain" fashion. A cable runs from the control console (or DMX512 control source) to the DMX connector on the first SL NITRO 510C LED STROBE Luminaire. Another cable runs from the other DMX connector on the first unit to a DMX connector on the next SL NITRO 510C LED STROBE Luminaire (or DMX512 device to be controlled).

Back of Fixture

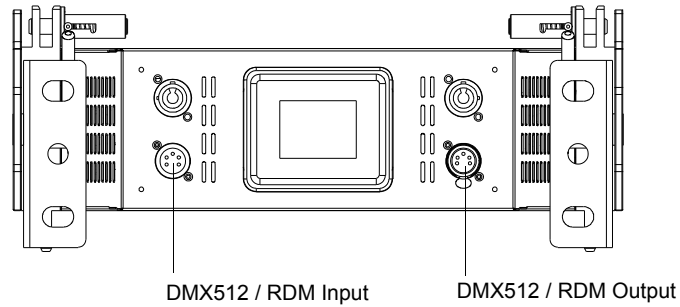

Figure 5: SL NITRO 510C LED STROBE Luminaire DMX512 Input / Output Connections

Note: For more information on DMX512 networking and systems, refer to "[Additional Resources for DMX512](#)" on page 1. For SL NITRO 510C LED STROBE Luminaire DMX Mapping, refer to "[DMX CONTROL](#)" on page 24.

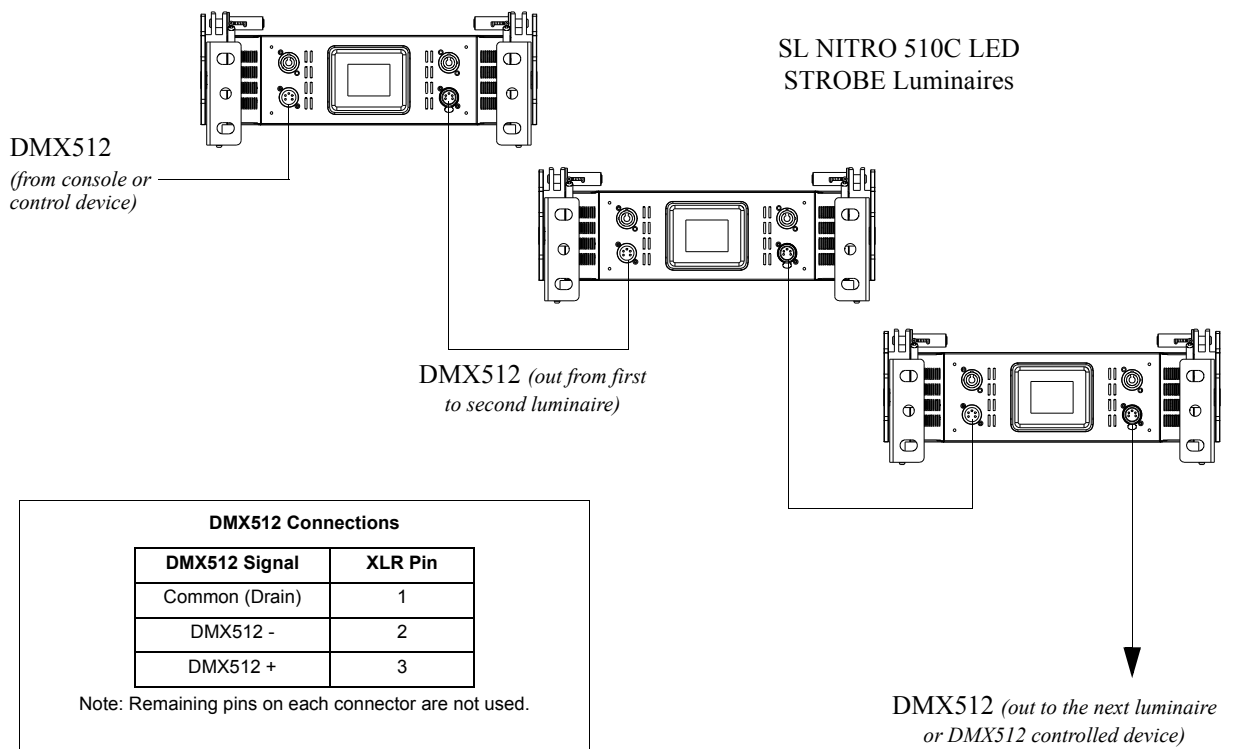

Figure 6: SL NITRO 510C LED STROBE Luminaire - DMX512 Connections

4. Mounting Luminaire

SL NITRO 510C LED STROBE Luminaires are provided with the ability to hang via truss hooks, clamps, etc. (sold separately). Simply attach hook, clamp, etc. to the SL NITRO 510C LED STROBE Luminaire's mounts in the

provided M9 holes. It is recommended (and may be required by local and national safety codes) to use and install a safety cable (sold separately). When hanging the fixture, be sure to leave enough space around the luminaire to allow proper, uninterrupted airflow for cooling and positioning.

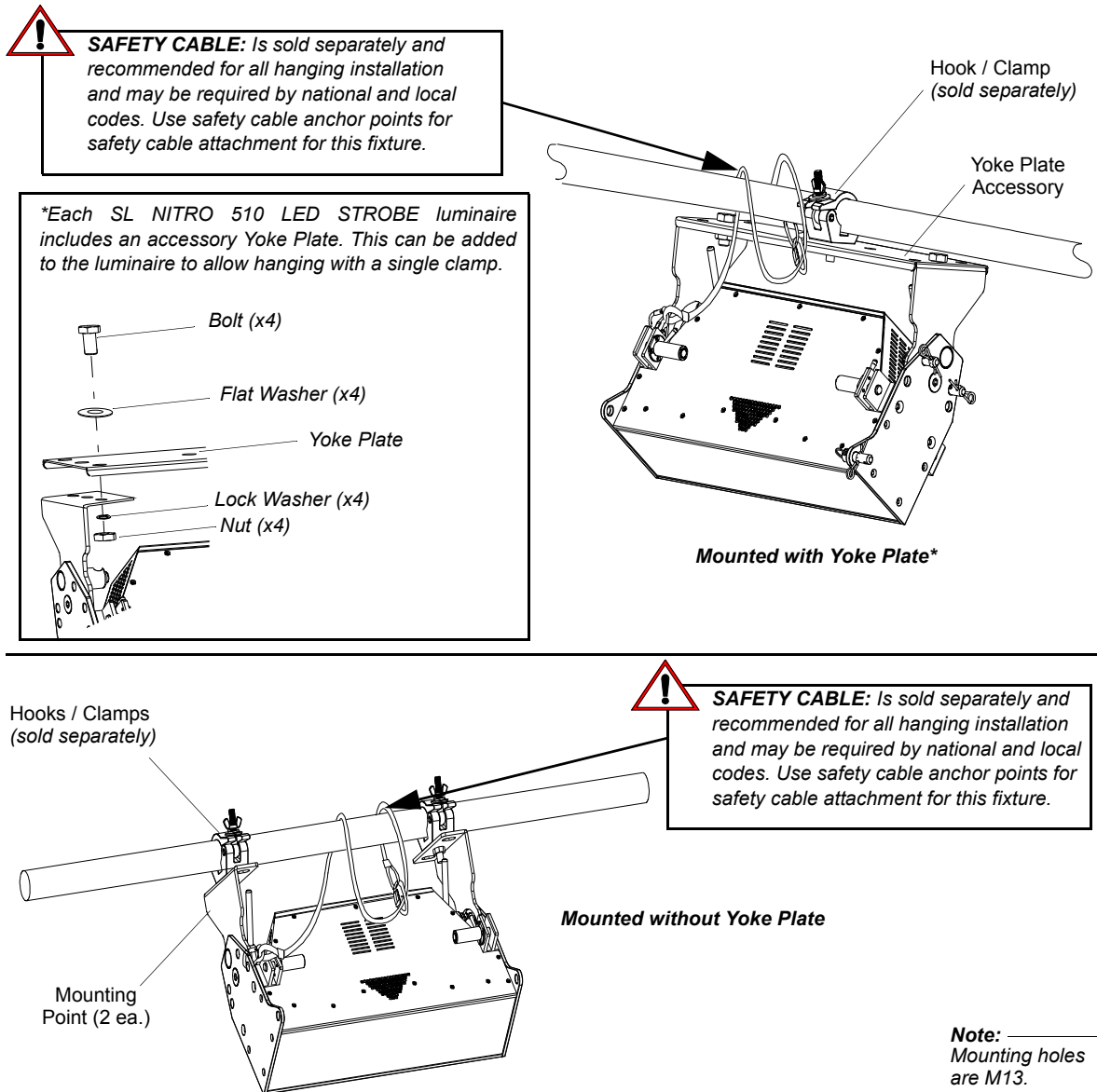

Figure 7: Mounting Luminaire

5. Connecting & Mounting Multiple luminaires

SL NITRO 510C LED STROBE luminaires include a built-in Quick Connect system that allows the luminaires to be physically connected together while retaining perfect pixel pitch. Units may be connected in top-to-bottom or side-by-side to allow for a wide range of configurations. In addition, they may be connected together with the SL BAR 520 RGBW LED luminaire.

Note: The SL NITRO 510C LED STROBE Luminaire and SL NITRO 510 LED Strobe Luminaire share the same chassis and can be combined together (or substituted for each other) as shown in this section of the manual.

Connecting luminaires Top-to-Bottom

Each SL NITRO 510C LED STROBE Luminaire includes two built-in Quick Connect slot and pin systems as illustrated in **Figure 8**. This allows a quick connection of units when stacked on top of each other. Up to twenty SL NITRO 510C LED STROBE Luminaires may be supported when connected using the Quick Connect system.

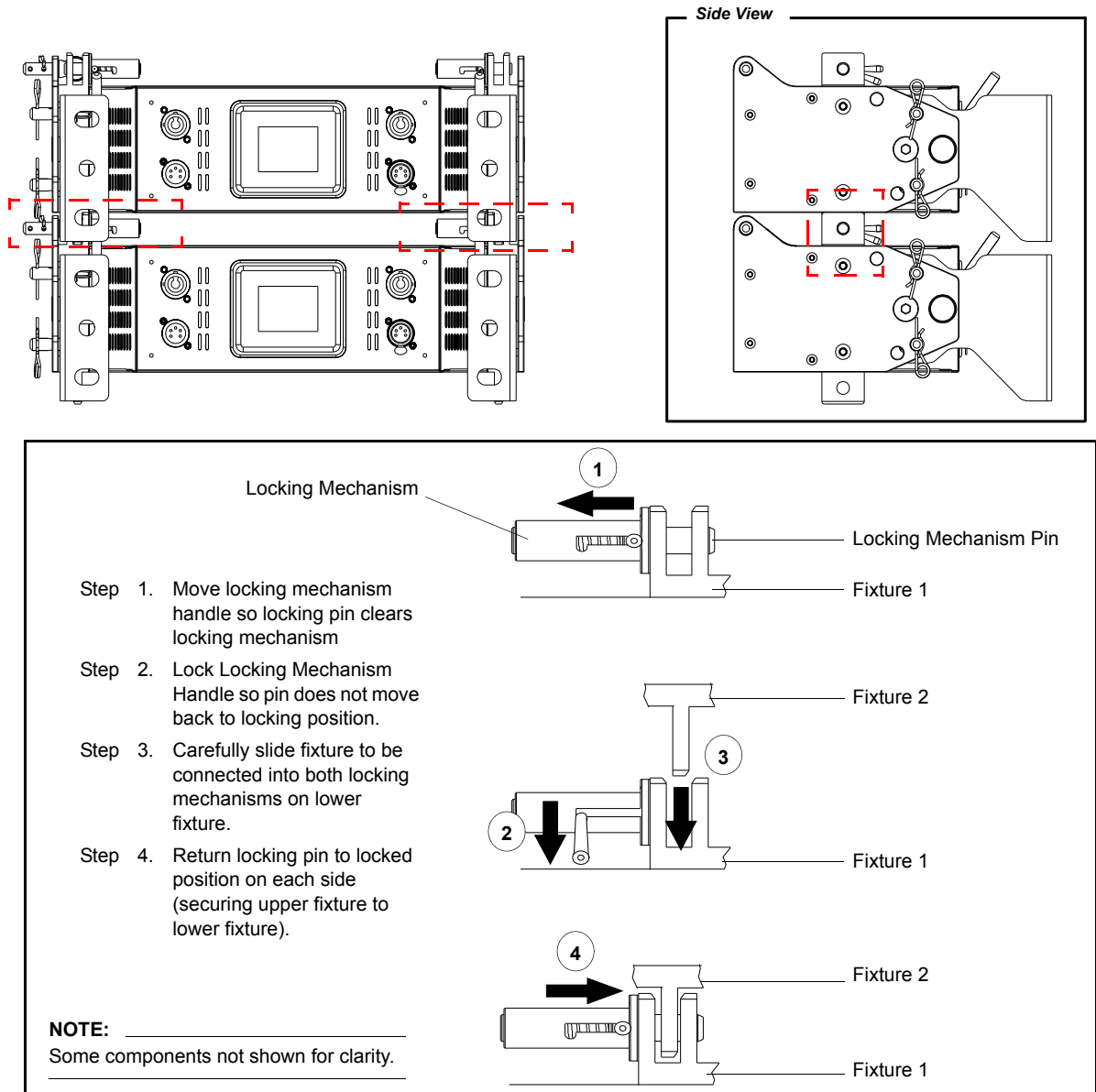

Figure 8: Connecting Luminaires Top-to-Bottom



WARNING! Your structure must be capable of properly supporting the weight of multiple connected fixtures. Each fixture must use an approved safety cable attached to a fixed object. Up to twenty SL NITRO 510C LED STROBE Luminaires may be supported when connected using the Quick Connect system. When connecting units together, ensure all Quick-Connect pins are in the "engaged" position.

Connecting luminaires Side-to-Side

Each SL NITRO 510C LED STROBE Luminaire ships with three Luminaire Connecting Pins as indicated in **Figure 9**. All three pins are used to connect two luminaires together linearly. Each fixture must be mounted using its own mounting hardware. The side-to-side pins are only to align the luminaires and do not provide hanging support.

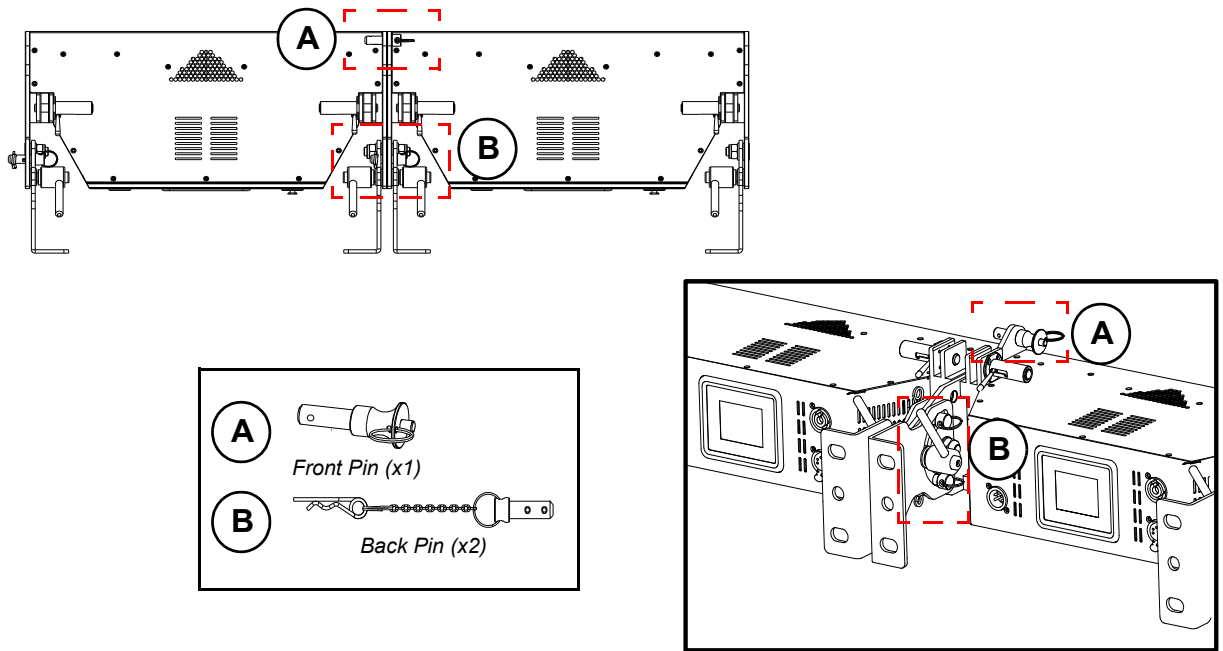

Figure 9: Connecting luminaires Side-to-Side



WARNING! Each fixture must use an approved safety cable attached to a fixed object.

6. Mounting SL NITRO 510C LED STROBE Luminaire with Other luminaires

The SL NITRO 510C LED STROBE Luminaire and SL BAR 520 LED Luminaire are designed to be connected together top-to-bottom and/or end-to-end using the same connecting hardware. The pixels of the SL BAR 520 LED Luminaire and the zones of the SL NITRO 510C LED STROBE Luminaire will be perfectly aligned when connected via the built-in connecting hardware.

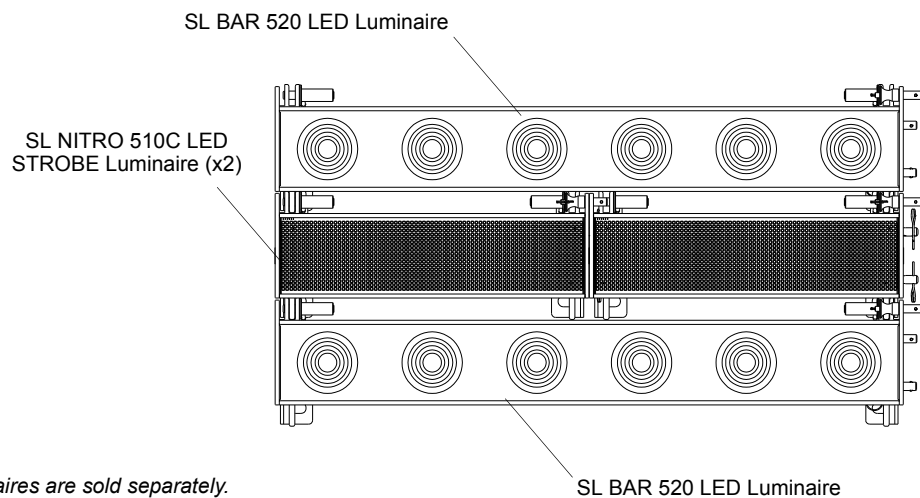

Note, all luminaires are sold separately.

Figure 10: Combining SL NITRO 510C and SL BAR 520 luminaires

Connecting Combined Luminaires Top-to-Bottom

When combining units connected top-to-bottom, two SL NITRO 510C LED STROBE Luminaires are first connected end-to-end and then connected top-to-bottom with a single SL BAR 520 luminaire.

Connecting Notes:



WARNING! Do not exceed 10 rows of combined luminaires connected together top-to-bottom with a single hanging point. If more than 10 rows are required, each ten rows must use its own connection to a fixed object.

- The two SL NITRO 510 units must have all three side-to-side pins installed (refer to **Figure 11** and "[Connecting Luminaires Side-to-Side](#)" on page 12).

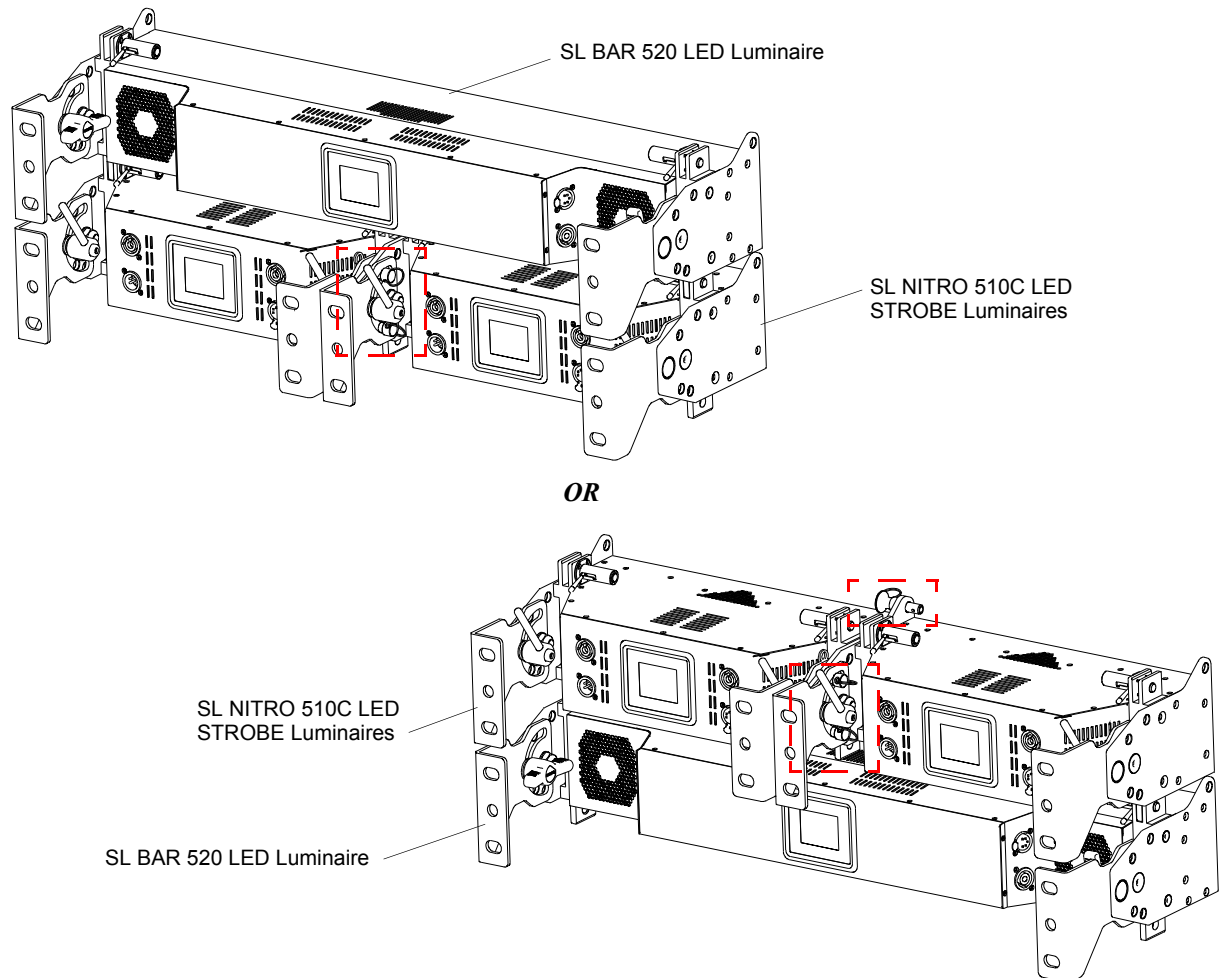
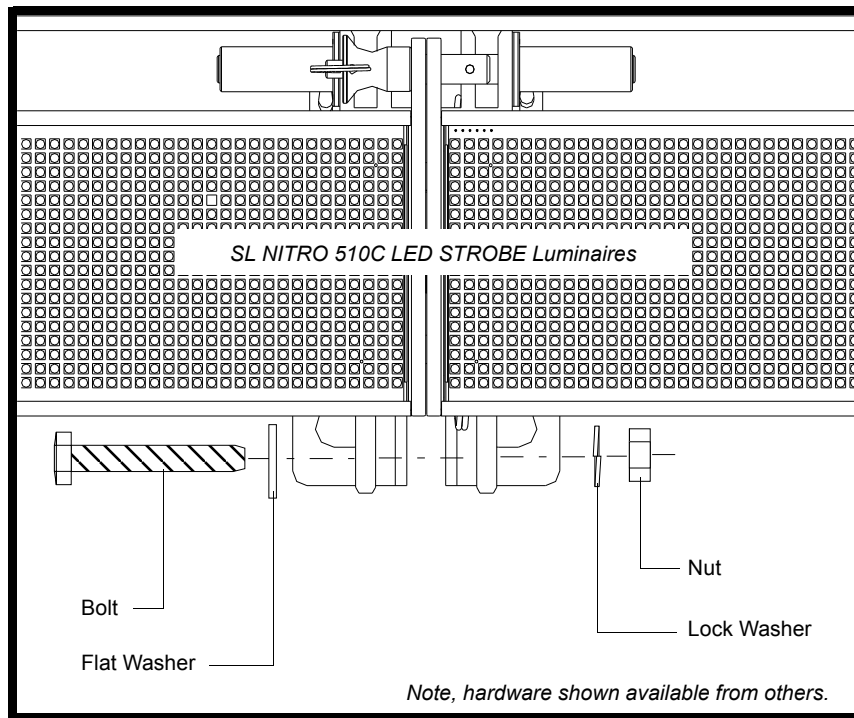
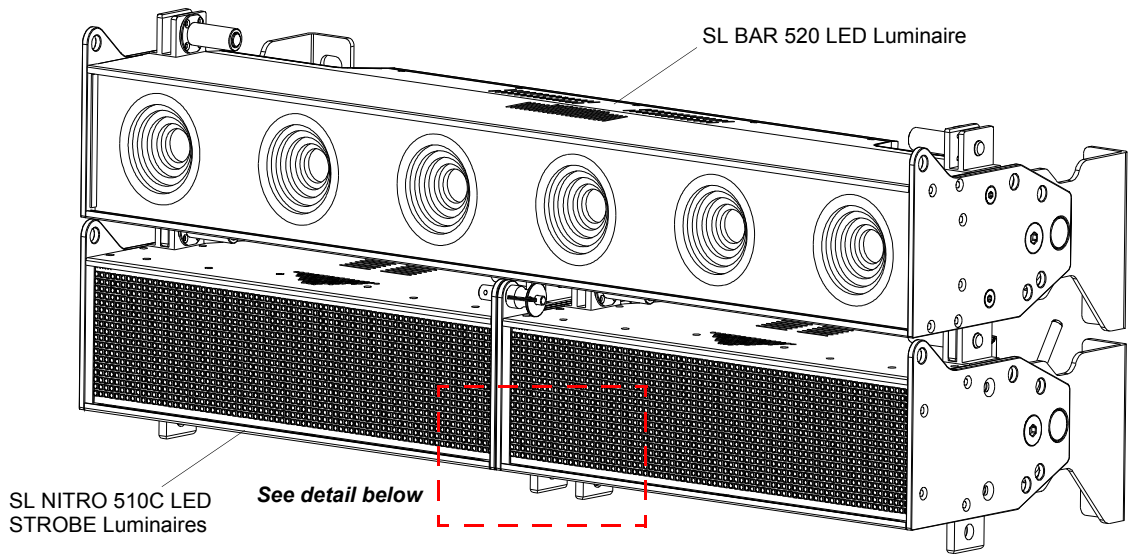

Figure 11: SL NITRO 510C LED STROBE Luminaires - Connections

- When two SL NITRO 510C LED STROBE Luminaires are combined with a SL BAR 520, there is no top-to-bottom connection available in the center.
- When a SL BAR 520 unit is mounted below the two SL NITRO 510C LED STROBE Luminaires, the top-to-bottom connections will rest on the center of the SL BAR 520, preventing the units from spreading apart in the center.
- If the bottom of a configuration has two SL NITRO 510C LED STROBE Luminaires below a single SL BAR 520, connect the bottom center top-to-bottom connections with the following hardware (available from others) to pre-

vent the spacing between the two SL NITRO 510C LED STROBE Luminaires from spreading apart at the center. Obtain and install:



- 1) One M10-1.5 x 25 mm Long, Hex Head Cap Bolt
 - 2) One 10 mm Flat Washer
 - 3) One 10 mm Split-Lock Washer
 - 4) One M10-1.5 (8 mm high) Hex Nut
- Installation is Flat Washer under Bolt Head, Bolt through both SL NITRO 510C LED STROBE Luminaire brackets, Lock Washer, and then Hex Nut. Hand tighten.



WARNING! Your structure must be capable of properly supporting the weight of multiple connected fixtures. Each fixture must use an approved safety cable attached to a fixed object. Up to ten luminaire rows may be supported when connected using the Quick Connect system.

Connecting Combined Luminaires Side-to-Side

When combining units connected side-to-side, all units connect using the same pin system and any combination can be created (refer to installation instructions and warnings contained in "[Connecting Luminaires Side-to-Side](#)" on page 12).

- Each SL NITRO 510C LED STROBE Luminaire and SL BAR 520 RGBW Luminaire ships with three Luminaire Connecting Pins as indicated in **Figure 9**.
- The three side-to-side pins must be installed per luminaire.
- All three pins are used to connect luminaires together linearly. Each fixture must be mounted using its own mounting hardware. The side-to-side pins are only to align the luminaires and do not provide hanging support.
- **Figure 12** shows an example of connecting luminaires side-by-side.

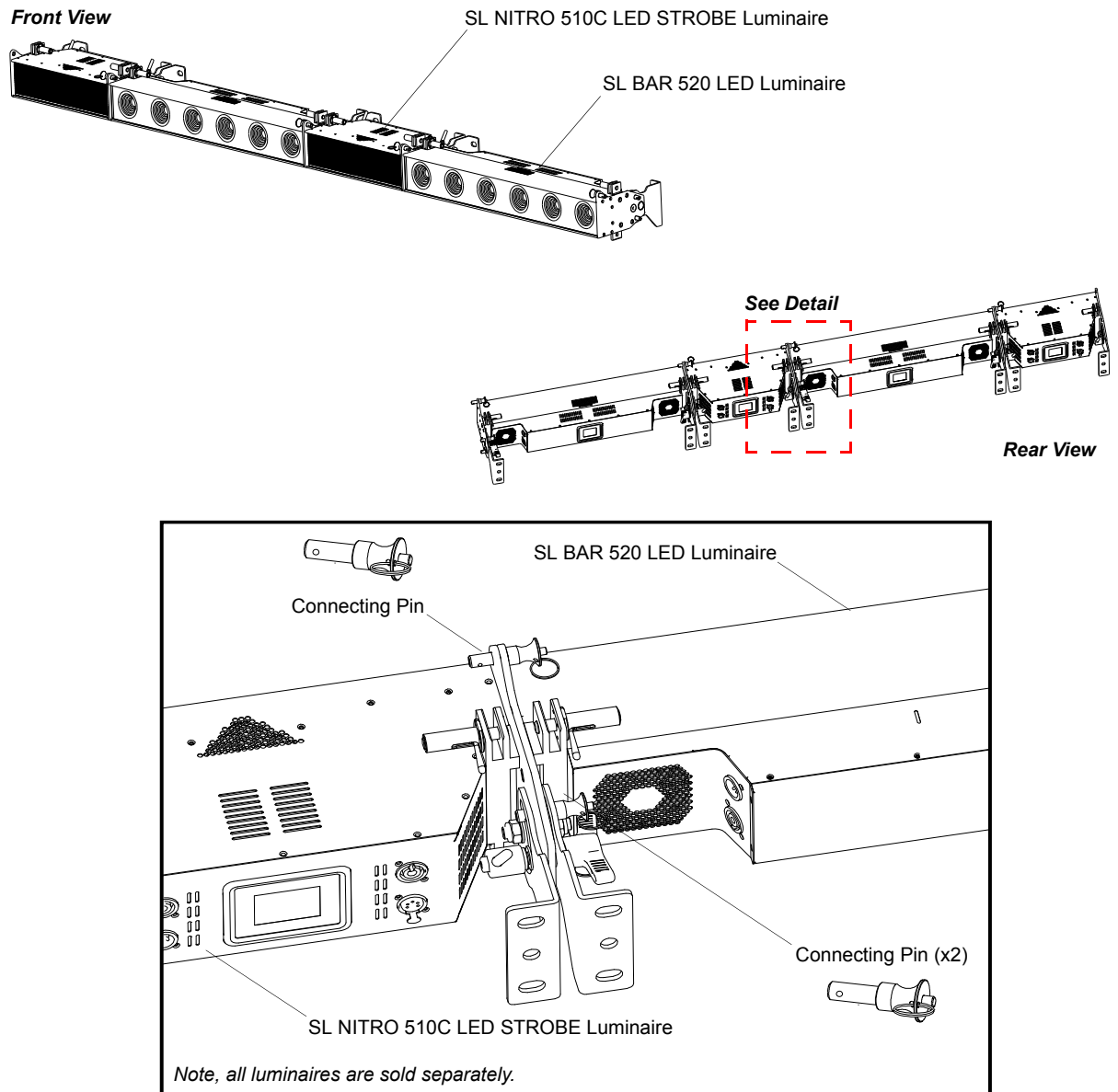

Figure 12: Connecting Combined Luminaires Side-to-Side Example



WARNING! Each fixture must use an approved safety cable attached to a fixed object.

OPERATION AND PROGRAMMING

1. LCD Display and Menu System

The SL NITRO 510C LED STROBE Luminaire's LCD Display and Menu System provides local control for accessing the following fixture's settings:

- Presets (Standard and User Defined)
- Effects (Chases - preloaded and user defined)
- Strobe / Timing
- Fixture Settings
- Fixture Lockout (to prevent changes)
- Password Setting
- Current Fixture Operational Status
- Setting the DMX512 Address

Note: If there are multiple luminaires in a system, changes would need to be made at each LCD Menu as desired. For SL NITRO 510C LED STROBE Luminaire menu structure, see "[SL NITRO 510C LED STROBE Luminaire Main Menu Options](#)" on page 17.

Upon power up, the LCD will display the main screen showing the product type/name. If DMX is enabled, the programmed address will appear after power up.

2. LCD Display and Menu System Operation

The LCD Display Menu system consists of several categories. Use the Menu Buttons to access and make changes to the menu items. When the desired menu item is reached, press the desired Menu Button to display the menu options and to navigate and configure the menu options as required.

To navigate and access menu settings/selections:

- Step 1. Make sure unit is powered and turned on.
- Step 2. Press the desired button (as shown in **Figure 13 on page 17**) to access menu categories.
- Step 3. Use UP | DOWN | LEFT | RIGHT arrow buttons to navigate through the various options and settings.
- Step 4. Make changes as desired.
- Step 5. Press CHECK MARK (OK) button to accept changes.

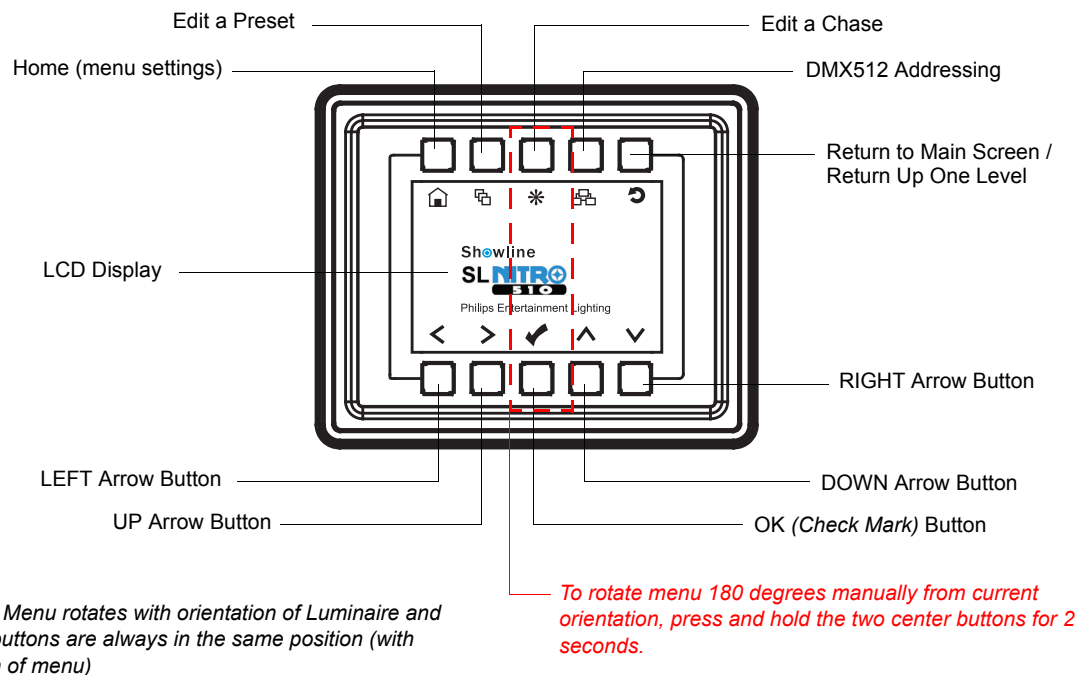

Figure 13: LCD Display and Menu System

3. SL NITRO 510C LED STROBE Luminaire Main Menu Options

Presets

Presets are stored values of the luminaire's LED settings that can be recalled via the menu system or DMX. You can customize up to 31 presets via the menu system.

Recalling or Editing Presets

To recall or edit a preset:

- Step 1. Select Preset from the main menu or from the Preset shortcut key.
- Step 2. The top left field indicates the current preset or Off, when this field is selected (highlighted in blue), use the left and right buttons to scroll through all presets
- Step 3. If you wish to edit the preset, use the Up and Down keys to scroll through the parameters. Once a parameter is selected, use the left and right arrow buttons to make adjustments.

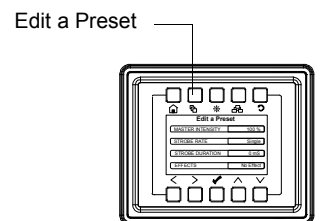

Notes:

- If security features are enabled, the Up and Down arrows will have no effect. See "[Settings/Security](#)" on page 18.
- Depending on the DMX map set assigned the DMX menu, different parameters will be available. See "[DMX CONTROL](#)" on page 24 for additional information.

- Step 4. Once all values are adjusted as desired, press the Check Mark button to save the preset.
- Step 5. The Save Preset Menu option will appear. Use the left and right arrow buttons to select the preset number to save to.

Note: This function allows you to save your current edits to a different preset number than you began editing. This is helpful to create copies of existing presets.

- Step 6. Press the Check Mark button to save the preset. You will be asked to confirm your saving operation.

Step 7. The preset is now saved and can be recalled via the menu or DMX.

Effects

Effects are chases stored values of the luminaire's LED settings that can be recalled via the menu system or DMX. There are 10 factory defined chases and eight user adjustable chases. You can adjust the master intensity, speed, and fade values for any of the 18 chases.

Use the Up and Down buttons to select parameters and the Left and Right buttons to assign the different general fixture settings. When finished, press the Check button to exit the menu level. The adjustable parameters are described in Table 3.

Table 3: Effects Parameters

Parameter	Description
User Chase / Built-in Chase	Select from the 18 different chases.
Master Intensity	Adjust the master intensity for ALL chases.
Total Steps	Displays the total steps used by the chase. This field is not editable.
Speed	The total time each step of the chase will be recalled.
Fade	The percentage of the time assigned by the speed that is crossfaded between steps.

Editing User Chases

Eight User chases can be further customized to create different effects on the fixture. To edit a User Chase, first use the up and down arrows to scroll to the Edit User Chase field and then press the Check Mark button. The Edit User Chase window will be displayed:

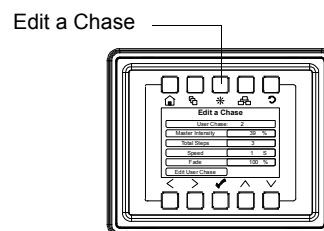

Use the Up and Down buttons to select parameters and the Left and Right buttons to assign the different general fixture settings. When finished, press the Check button to exit the menu level.

To edit and save a Step:

- Step 1. Select Edit Step or New Step from the Edit User Chase menu.
- Step 2. The top left field indicates the preset or color filter to be used for the step. When set to OFF no preset or color filter is to be used. Use the left and right buttons to scroll through all presets and color filters.
- Step 3. Use the Up and Down keys to scroll through the output parameters. Once a parameter is selected, use the left and right arrow buttons to make adjustments.

Notes:

- If security features are enabled, the Up and Down arrows will have no effect. See ["Settings/Security" on page 18](#).
- Depending on the DMX map set assigned the DMX menu, different parameters will be available. See ["DMX CONTROL" on page 24](#) for additional information.

Step 4. Once all values are adjusted as desired, press the Check Mark button to return to the Edit User Chase screen.

Step 5. Continue editing steps as needed. When complete, press the Return to Main Menu button or up one level (*as shown to the right*), to exit the Edit User Chase window.



Step 6. The user chase is now saved and can be recalled via the menu or DMX.

Settings/Security

All Showline fixtures have a multiple level locking feature. This allows you to configure the fixture and allow different menu access to multiple users. The menu system can be locked instantly or assigned to power on to a particular lock level. You can assign three different 4-digit PIN (personal identification number) codes to each unlock specific levels of functionality within the menu system.

Anytime the fixture is locked, each PIN code will unlock all functions except the pertaining features assigned via the security level.

Note: The Level 3 PIN will always unlock all functions.

Table 4: Security Lock Levels

Lock Level	Menu Functions Affected
Level 1	Edit Presets, Edit Chases, and Settings Menu
Level 2	Settings Menu
Level 3	All

Use the Up and Down buttons to select security PIN codes. Press the Check button and then use Left and Right and Up Down buttons to assign the pin code. Press the Check button to save the new PIN code.

The Power-Up Level parameter assigns a lock level to the fixture when power is applied. Use the Up and Down buttons to select the Power-Up Level, and then use the Left and Right buttons to select the Power-up Level option.

Table 5: PIN Level Parameters

Parameter	Description
Enter Pass PIN	Enter a PIN code matching the level codes assigned in the Settings/Security menu to toggle the current security level.
Level 1 PIN	Edit the PIN code used to toggle the Level 1 security.
Level 2 PIN	Edit the PIN code used to toggle the Level 2 security.
Level 3 PIN	Edit the PIN code used to toggle the Level 3 security.
Power-up Level	Select the security level to default to when the fixture is powered ON. <ul style="list-style-type: none"> • Disable PIN will disable all security functions. • Locked will lock all functions.

Settings/General

Use the Up and Down buttons to select parameters and the Left and Right buttons to assign the different general fixture settings. When finished, press the Check button to exit the menu level. The adjustable parameters are described in Table 6.

Table 6: General Level Parameters

Parameter	Description
Power-Up	Select the action of the fixture when the unit is powered ON. You can select from Off, Last Set, presets, and chases.
Mode	Select either Master/Slave (see Master / Slave Operational Mode for more information).
Dimming Curve	Select one of four dimming curve choices (see Dimming Curve Selection for more information).
Fan Control	Select Auto of Off fan operation (see DMX CONTROL for more information).

Settings/Factory Default

Factory default menu settings can be recalled through this menu option. You can select if you wish to overwrite the user edited preset and chases.

Use the Up and Down buttons to select parameters and the Left and Right buttons to assign the different settings. When finished, press the Check button to exit the menu level. The adjustable parameters are described in Table 7.

Table 7: Factory Default Parameters

Parameter	Description
Protected	<ul style="list-style-type: none"> • No - all menu items are able to be restored to factory defaults. • Preset & Chase - user edited Presets and Chases are not able to be restored to factory defaults.
Load Factory	<ul style="list-style-type: none"> • No - no action. • Yes - restore to factory default menu settings.

Settings/DMX

DMX configuration options are available in the DMX menu.

Use the Up and Down buttons to select parameters and the Left and Right buttons to assign the fixture's DMX settings. When finished, press the Check button to exit the menu level. The adjustable parameters are described in Table 8.

Table 8: DMX Setting Parameters

Parameter	Description
DMX Enable	<ul style="list-style-type: none"> • Enable - Fixture will respond to DMX commands/signals. • Disable - Fixture will ignore DMX commands/signals.
Address	Assigns the fixture's DMX start address.
Map	Selects the DMX map for the fixture to use (see DMX CONTROL section for more information).
When no DMX	Selects the action of the fixture when the unit is powered ON and not receiving DMX. <ul style="list-style-type: none"> • Off - Turn off all LED output. • Last Action - restore the last menu action. • Power-up - follow the power-up value in the settings menu. • Hold - continue with the last DMX values received.
LED Group	Selects the number of LED groups to control via DMX (see DMX CONTROL section for more information)

Settings/Display

Options of the fixture's LCD display can be adjusted in the Display menu.

Use the Up and Down buttons to select parameters and the Left and Right buttons to assign the fixture's DMX settings. When finished, press the Check button to exit the menu level. The adjustable parameters are described in Table 9.

Table 9: LCD Display Parameters

Parameter	Description
Flip Display	<ul style="list-style-type: none"> • Yes - The display will be inverted. • No - The display will not be inverted. • Auto - The display will automatically invert depending upon fixture orientation.
Off Time	Assign a time for the display to automatically turn off after the last button press. A value of ON will leave the display on indifferently.
Language Select	English is the only language currently supported.

Lock Fixture

You can lock all fixture functions, requiring a PIN code to access the menu functions. When you select this menu item, you are asked to confirm that you wish to lock the fixture. Once locked, all menu items can only be accessed by entering one of the three PIN codes assigned in the Settings/Security menu. (see ["Settings/Security" on page 18](#) for more information). The PIN code used to unlock the fixture will only unlock the functionality assigned to that particular PIN code.

Note: When the fixture is powered off, the Lock Fixture function will be disabled. To assign fixture power-up security refer to (see ["Settings/Security" on page 18](#) for more information).

Password (PassPIN)

The Password menu item will display an Enter PassPIN dialog box. Use the Up Down Left Right buttons to enter a PIN code matching the codes assigned in the Settings/Security menu to toggle the current security level.

Status





The Status screen displays the current value of the master intensity and LED zone of the fixture. Use the Up Down Left Right arrows to scroll through the different zones and view their levels.

- The last Status item displayed shows the RDM UID and current Firmware Version.
- Press the Check Mark button to exit the Status screen.

Quick Selection Buttons

The Showline menu system includes four quick selection buttons on the top of the menu. These keys provide direct access to common functions and act as shortcuts to main menu items as described in Table 9.

Table 10: Quick Select Buttons

Quick Select Button	Description
	Main Menu Refer to Settings/General for more information.
	Edit a Preset Refer to Recalling or Editing Presets for more information.
	Effects / Edit a Chase Refer to Effects and Editing User Chases for more information.
	DMX Start Address Refer to DMX Address for more information.
	Return to Main Menu / Return Up a Menu Item

DMX Address

You can display and edit the current DMX start address for the fixture by pressing the Quick Select button on the top of the menu system (as shown right). The current DMX start address will be display in large digits.

To edit the DMX start address:

- Step 1. Press the Check Mark button to begin the DMX start address editing. The last digit will change to a blue color.
- Step 2. Use the UP and Down arrows to change the value of the currently selected digit.
- Step 3. Use the Left and Right arrows to select another digit to adjust.
- Step 4. Press the Check Mark button to save the new DMX Start Address.

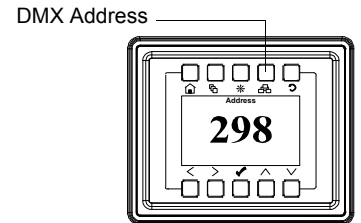

4. Harmonize Color Calibration

Harmonize is a proprietary, advanced LED color matching system, consisting of 3 correction modules: RGB, RGBW and Cool White/Warm White. Every Showline fixture undergoes rigorous testing to provide you with consistent control of color and intensity as well as output of the highest quality.

When enabled either via DMX or the fixture's menu, the Harmonize technology will ensure that colors match from fixture-to-fixture and pixel-to-pixel. As the Harmonize system matches Showline products, they will all operate in the same color space. Use the Harmonize system when perfect color matching is an essential requirement.

Note: When attempting to achieve the most saturated colors possible, disable the Harmonize color calibration.

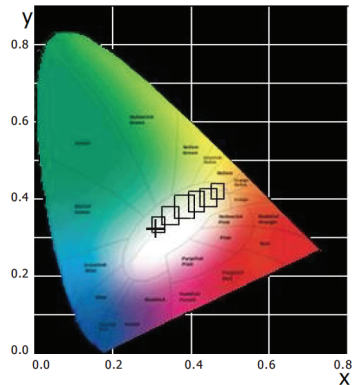

5. Dimming Curve Selection

Through the menu, you are able to select one of four dimming curves:

- Linear Curve
- PL_Curve
- S_Curve
- Square Curve

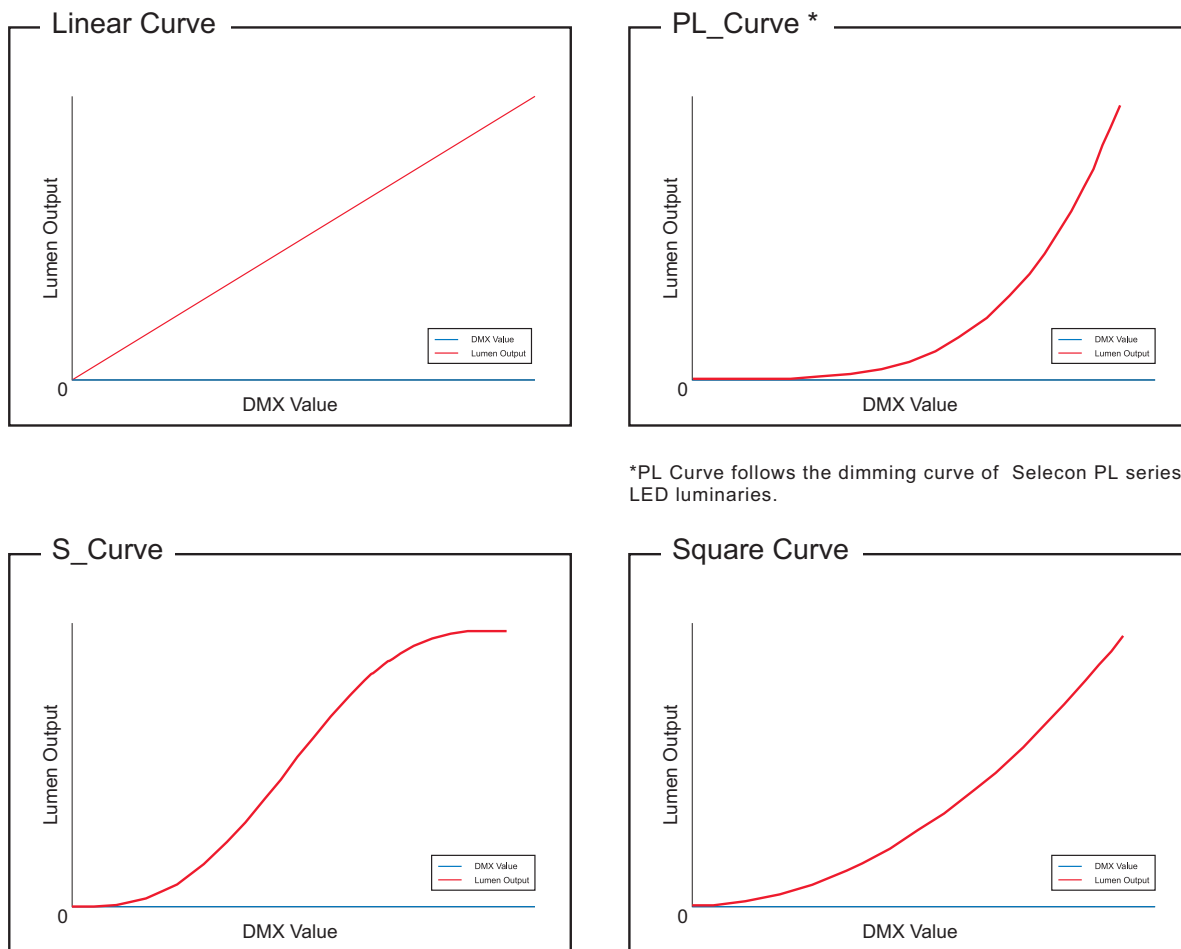

Figure 14: SL NITRO 510C LED STROBE Luminaire Dimmer Curves

6. Master / Slave Operational Mode

The Master / Slave Operational Mode allows one SL NITRO 510C LED STROBE Luminaire to act as the "Master" unit and all other connected units are controlled by this unit. When a unit is set to "Slave" mode, it will only listen to and follow any commands sent from a "Master" unit. Only one "Master" unit is allowed in this type of operation.

To setup a master / slave network:

- Step 1. Set the first device in the DMX512 chain to **Master Mode** through the unit's menu system.
- Step 2. Set all other connected units to **Slave Mode**.
- Step 3. The master unit can be controlled via DMX512, RDM or through standalone operation (self-contained network utilizing on-board effects). The slave units will mimic the master unit's operation in all cases.

Note: For more information on DMX512 networking and systems, refer to "[Additional Resources for DMX512](#)" on page 1. For SL NITRO 510C LED STROBE Luminaire DMX Mapping, refer to "[DMX CONTROL](#)" on page 24.

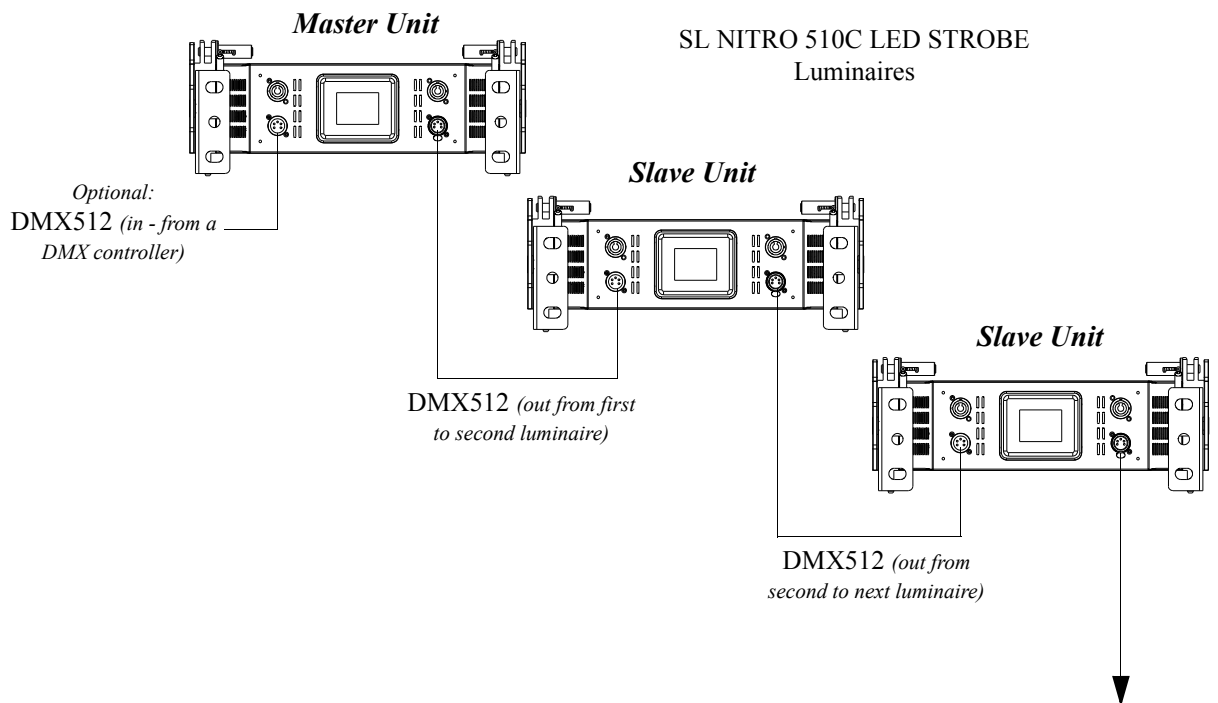

Figure 15: SL NITRO 510C LED STROBE Luminaire - Master / Slave Configuration

DMX CONTROL

1. RGB & W Operation

The SL NITRO 510C LED STROBE Luminaire operates either as an RGB or White strobe, with the two engines operating separately from each other. It is not possible to utilize both RGB and White values to create a combined output of the two systems. When operating under DMX control, the SL NITRO 510C LED STROBE Luminaire utilizes an internal LTP (*Latest Takes Precedence*) system that will automatically respond to the Latest color or white value change. This results in only the most recent RGB or White parameter being displayed.

For instance, when all zones are set to red at DMX 255 and then the white channel DMX value level changes, the white will be displayed instead of the red. If the red level is again adjusted, then the red will be displayed and the white deactivated. If any RGB or W value with precedence reaches zero, then it is considered non-active and any previously overridden RGB or W value will automatically take precedence and be displayed.

The automatic LTP ability of the SL NITRO 510C LED STROBE Luminaire allows quick creation of color chases, white flashes and other effects by intelligently responding to DMX value changes. Each zone is capable of its own LTP system so that any combination of RGB and W can be displayed on the front of the luminaire.

2. DMX Maps

This section contains information for operating the luminaire using one of the DMX control modes as set by the luminaire's menu system:

- ["RGBW Full Mode"](#) (starting below)
- ["RGBW Expanded Mode"](#) on page 29
- ["RGBW 16-Bit Mode"](#) on page 33
- ["RGBW 8-Bit Mode"](#) on page 37
- ["6-Channel Mode"](#) on page 41
- ["Mapping 16-Bit Mode"](#) on page 44

For Menu options and detailed information, see ["LCD Display and Menu System"](#) on page 16.

Note: These tables assume a DMX start address of 1. When a different starting address is used, this address becomes channel 1 function and other functions follow in sequence.

3. RGBW Full Mode

Table 11 provides DMX channel mapping of the DMX512 control values when the SL NITRO 510C LED STROBE Luminaire is in RGBW Full DMX512 mode (as set by the luminaire's menu system).

Table 11: DMX Channel Mapping (RGBW Full Mode)

DMX Channel	Parameter	Range DMX	Range%	Default - recommended console default values	Description
1	Intensity - High Byte	0 - 65535	0 - 100%	0	16-bit control for the intensity of the LED settings - 0 to 65535 (full)
2	Intensity - Low Byte				
3	Color Presets	0 - 255	0 - 100%	0	Select presets, variable color filters or chases as follows: Channel OFF (disabled) DMX 0 - 4 Preset 0 (OFF) DMX 5 - 6 Preset 1 DMX 7 - 8 Preset 2 DMX 9 - 10 Preset 3 DMX 11 - 12 Preset 4 DMX 13 - 14 Preset 5 DMX 15 - 16 Preset 6 DMX 17 - 18 CONTINUED NEXT PAGE

Table 11: DMX Channel Mapping (RGBW Full Mode)

3	Color Presets	0 - 255	0 - 100%	0	<p>CONTINUED FROM PREVIOUS PAGE</p> <p> Preset 7 DMX 19 - 20 Preset 8 DMX 21 - 22 Preset 9 DMX 23 - 24 Preset 10 DMX 25 - 26 Preset 11 DMX 27 - 28 Preset 12 DMX 29 - 30 Preset 13 DMX 31 - 32 Preset 14 DMX 33 - 34 Preset 15 DMX 35 - 36 Preset 16 DMX 37 - 38 Preset 17 DMX 39 - 40 Preset 18 DMX 41 - 42 Preset 19 DMX 43 - 44 Preset 20 DMX 45 - 46 Preset 21 DMX 47 - 48 Preset 22 DMX 49 - 50 Preset 23 DMX 51 - 52 Preset 24 DMX 53 - 54 Preset 25 DMX 55 - 56 Preset 26 DMX 57 - 58 Preset 27 DMX 59 - 60 Preset 28 DMX 61 - 62 Preset 29 DMX 63 - 64 Preset 30 DMX 65 - 66 Preset 31 DMX 67 - 68 CF_0_Color OFF DMX 69 - 70 CF_1_White 10000K DMX 71 - 72 CF_2_White 8000K DMX 73 - 74 CF_3_White 6500K DMX 75 - 76 CF_4_White 5600K DMX 77 - 78 CF_5_White 5000K DMX 79 - 80 CF_6_White 4500K DMX 81 - 82 CF_7_White 4000K DMX 83 - 84 CF_8_White 3200K DMX 85 - 86 CF_9_White 3000K DMX 87 - 88 CF_10_White 2700K DMX 89 - 90 CF_11_Moroccan Pink DMX 91 - 92 CF_12_Pink DMX 93 - 94 CF_13_Flesh Pink DMX 95 - 96 CF_14_Bright Rose DMX 97 - 98 CF_15_Follies Pink DMX 99 - 100 CF_16_Fuchsia Pink DMX 101 - 102 CF_17_Surprise Pink DMX 103 - 104 CF_18_Congo Blue DMX 105 - 106 CF_19_Blue DMX 107 - 108 CF_20_Virgin Blue DMX 109 - 110 CF_21_Midnight Maya DMX 111 - 112 CF_22_Double C.T Blue DMX 113 - 114 CF_23_Slate Blue DMX 115 - 116 CF_24_Regal Blue DMX 117 - 118 CF_25_Full C.T Blue DMX 119 - 120 CF_26_Steel Blue DMX 121 - 122 CF_27_Lighter Blue DMX 123 - 124 CF_28_Cyan DMX 125 - 126 CF_29_Marine Blue DMX 127 - 128 CF_30_Soft Green DMX 129 - 130 CF_31_Moss Green DMX 131 - 132 CF_32_Green DMX 133 - 134 CF_33_Fem Green DMX 135 - 136 CF_34_JAS Green DMX 137 - 138 CF_35_Pale Green DMX 139 - 140 CF_36_Spring Yellow DMX 141 - 142 CF_37_Yellow DMX 143 - 144 CF_38_Deep Amber DMX 145 - 146 CF_39_Chrome Orange DMX 147 - 148 CF_40_Orange DMX 149 - 150 CF_41_Magenta DMX 151 - 152 CF_42_Flame Red DMX 153 - 154 CF_43_Purple DMX 155 - 156 Rotate CW Fast -> Slow DMX 157 - 171 Rotate ACW Slow -> Fast DMX 172 - 186 Random Color Fast -> Slow DMX 187 - 201 </p> <p>CONTINUED NEXT PAGE</p>
---	---------------	---------	----------	---	---

Table 11: DMX Channel Mapping (RGBW Full Mode)

3	Color Presets	0 - 255	0 - 100%	0	<p>CONTINUED FROM PREVIOUS PAGE</p> <p>Chase1 DMX 202 - 204 Chase2 DMX 205 - 207 Chase3 DMX 208 - 210 Chase4 DMX 211 - 213 Chase5 DMX 214 - 216 Chase6 DMX 217 - 219 Chase7 DMX 220 - 222 Chase8 DMX 223 - 225 Chase9 DMX 226 - 228 Chase10 DMX 229 - 231 User Chase1 DMX 232 - 234 User Chase2 DMX 235 - 237 User Chase3 DMX 238 - 240 User Chase4 DMX 241 - 243 User Chase5 DMX 244 - 246 User Chase6 DMX 247 - 249 User Chase7 DMX 250 - 252 User Chase8 DMX 253 - 255</p>
4	Strobe Effects	0 - 255	0 - 100%	0	<p>Controls strobe operation as follows:</p> <p>No Effect = DMX 0 - 5 (default) Ramp Up = DMX 6 - 42 Ramp Down = DMX 43 - 85 Ramp up/down = DMX 86 - 128 Random = DMX 129 - 171 Top row only = DMX 172 - 173 Bottom row only = DMX 174 - 175 Left zone only = DMX 176 - 178 Center zone only = DMX 179 - 180 Right zone only = DMX 181 - 182 Checker pattern A = DMX 183 - 184 Checker pattern B = DMX 185 - 186 Random zones = DMX 187 - 214 Circle zone chase CW = DMX 215 - 235 Circle zone chase CCW = DMX 236 - 255</p>
5	Intensity Timing	0 - 255	0 - 100%	255	<p>Allows for timing control of intensity. Channel should default to 255 for smoothest actions using console and/or manual fades.</p>
6	Color Timing	0 - 255	0 - 100%	255	<p>Allows for timing control of color parameters. Channel should default to 255 for smoothest actions using console and/or manual fades.</p>
7	Control Channel	0 - 255	0 - 100%	0	<p>Control channel operation. Set control channel value to desired action, hold value for at least 5 seconds, then turn to 0. Set control channel value to 0 without any scaling.</p> <p>Default Setting on Console = DMX 0-4 Dimming Curve_linear = DMX 30 - 34 Dimming Curve_Square = DMX 35- 39 Dimming Curve_S-Curve = DMX 40 - 44 Dimming Curve_PL-Curve = DMX 45 - 49 Calibration_OFF = DMX 70 - 74 Calibration_ON = DMX 75 - 79 Fan_Auto = DMX 80 - 84 Fan_Off = DMX 85 - 89</p> <p><i>The following is only available for "Zones Mapping" protocol. The following is instantly applied and DOES NOT require the 5 second hold.</i></p> <p>Combined zone control - (all zones follow zone 1 setting) = DMX 100 - 104</p> <p><i>The following is only available for "2 Zones Modes". The following is instantly applied and does not require the 5 second hold:</i> Linear Pattern = DMX 105 - 108* Checker Pattern = 109 - 112* *See Figure 16 on page 27.</p> <p>Not Used = DMX 113 - 250 (<i>Reserved for future use</i>)</p>

Table 11: DMX Channel Mapping (RGBW Full Mode)

8	Zone 1 - 6 Intensity	0 - 255	0 - 100%	0	8-bit control for the intensity of the Zones - 0 to 255 (full)
9	Red 1 - 6 - High	0 - 65535	0 - 100%	0	16-bit control of Red LEDs from 0 to full
10	Red 1 - 6 - Low				
11	Green 1 - 6 - High	0 - 65535	0 - 100%	0	16-bit control of Green LEDs from 0 to full
12	Green 1 - 6 - Low				
13	Blue 1 - 6 - High	0 - 65535	0 - 100%	0	16-bit control of Blue LEDs from 0 to full
14	Blue 1 - 6 - Low				
15	White 1 - 6 - High	0 - 65535	0 - 100%	0	16-bit control of White LEDs from 0 to full
16	White 1 - 6 - Low				
17	Zone 1 - 6 Red Strobe Duration	0 - 255	0 - 100%	0	Controls strobe duration of Red LEDs only. Refer to "Strobe Duration DMX Timing Detail" on page 47.
18	Zone 1 - 6 Red Strobe Rate	0 - 255	0 - 100%	0	Controls strobe rate operation of Red LEDs only. Refer to "Strobe Rate DMX Timing Detail" on page 46.
19	Zone 1 - 6 Green Strobe Duration	0 - 255	0 - 100%	0	Controls strobe duration of Green LEDs only. Refer to "Strobe Duration DMX Timing Detail" on page 47.
20	Zone 1 - 6 Green Strobe Rate	0 - 255	0 - 100%	0	Controls strobe rate operation of Green LEDs only. Refer to "Strobe Rate DMX Timing Detail" on page 46.
21	Zone 1 - 6 Blue Strobe Duration	0 - 255	0 - 100%	0	Controls strobe duration of Blue LEDs only. Refer to "Strobe Duration DMX Timing Detail" on page 47.
22	Zone 1 - 6 Blue Strobe Rate	0 - 255	0 - 100%	0	Controls strobe rate operation of Blue LEDs only. Refer to "Strobe Rate DMX Timing Detail" on page 46.
23	Zone 1 - 6 White Strobe Duration	0 - 255	0 - 100%	0	Controls strobe duration of White LEDs only. Refer to "Strobe Duration DMX Timing Detail" on page 47.
24	Zone 1 - 6 White Strobe Rate	0 - 255	0 - 100%	0	Controls strobe rate operation of White LEDs only. Refer to "Strobe Rate DMX Timing Detail" on page 46.

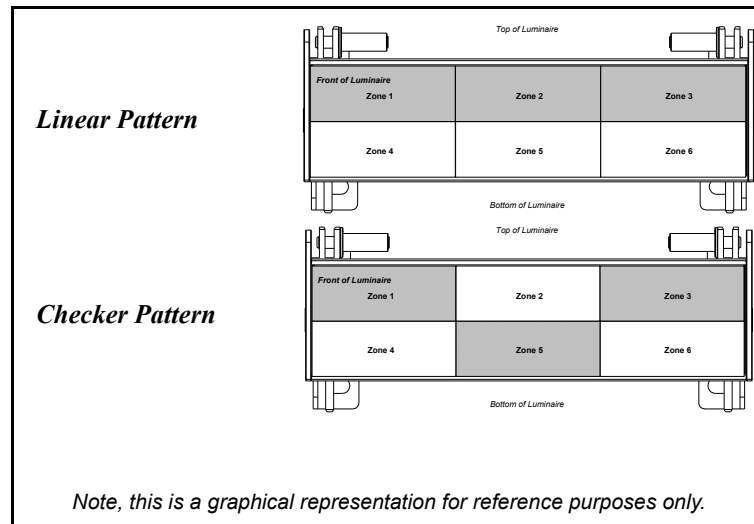

Figure 16: Linear & Checker Pattern

4. RGBW Full Mode (Zones)

Table 12 provides DMX channel mapping of all DMX512 control values when the SL NITRO 510C LED STROBE Luminaire is operated in various Groups (Zones) Control Mode when set to RGBW Full Mode.

Table 12: DMX Channel Mapping (RGBW Full Group Modes)

DMX CHANNEL	6 Zone MODE	3 Zone MODE	2 Zone MODE	1 Zone MODE
1	Master Intensity - High	Master Intensity - High	Master Intensity - High	Master Intensity - High
2	Master Intensity - Low	Master Intensity - Low	Master Intensity - Low	Master Intensity - Low
3	Color Presets	Color Presets	Color Presets	Color Presets
4	Effects	Effects	Effects	Effects
5	Intensity Timing	Intensity Timing	Intensity Timing	Intensity Timing
6	Color Timing	Color Timing	Color Timing	Color Timing
7	Control	Control	Control	Control
8	Zone 1 Intensity	Zone 1+4 Intensity	Zone 1-3 Intensity	Zone 1-6 Intensity
9	Red_1 - High Byte	Red_1+4 - High Byte	Red_1-3 - High Byte	Red_1-6 - High Byte
10	Red_1 - Low Byte	Red_1+4 - Low Byte	Red_1-3 - Low Byte	Red_1-6 - Low Byte
11	Green_1 - High Byte	Green_1+4 - High Byte	Green_1-3 - High Byte	Green_1-6 - High Byte
12	Green_1 - Low Byte	Green_1+4 - Low Byte	Green_1-3 - Low Byte	Green_1-6 - Low Byte
13	Blue_1 - High Byte	Blue_1+4 - High Byte	Blue_1-3 - High Byte	Blue_1-6 - High Byte
14	Blue_1 - Low Byte	Blue_1+4 - Low Byte	Blue_1-3 - Low Byte	Blue_1-6 - Low Byte
15	White_1 - High Byte	White_1+4 - High Byte	White_1-3 - High Byte	White_1-6 - High Byte
16	White_1 - Low Byte	White_1+4 - Low Byte	White_1-3 - Low Byte	White_1-6 - Low Byte
17	Zone 1 Red Strobe Duration	Zone 1+4 Red Strobe Duration	Zone 1-3 Red Strobe Duration	Zone 1-6 Red Strobe Duration
18	Zone 1 Red Strobe Rate	Zone 1+4 Red Strobe Rate	Zone 1-3 Red Strobe Rate	Zone 1-6 Red Strobe Rate
19	Zone 1 Green Strobe Duration	Zone 1+4 Green Strobe Duration	Zone 1-3 Green Strobe Duration	Zone 1-6 Green Strobe Duration
20	Zone 1 Green Strobe Rate	Zone 1+4 Green Strobe Rate	Zone 1-3 Green Strobe Rate	Zone 1-6 Green Strobe Rate
21	Zone 1 Blue Strobe Duration	Zone 1+4 Blue Strobe Duration	Zone 1-3 Blue Strobe Duration	Zone 1-6 Blue Strobe Duration
22	Zone 1 Blue Strobe Rate	Zone 1+4 Blue Strobe Rate	Zone 1-3 Blue Strobe Rate	Zone 1-6 Blue Strobe Rate
23	Zone 1 White Strobe Duration	Zone 1+4 White Strobe Duration	Zone 1-3 White Strobe Duration	Zone 1-6 White Strobe Duration
24	Zone 1 White Strobe Rate	Zone 1+4 White Strobe Rate	Zone 1-3 White Strobe Rate	Zone 1-6 White Strobe Rate
25	Zone 2 Intensity	Zone 2+5 Intensity	Zone 4-6 Intensity	
26	Red_2 - High Byte	Red_2+5 - High Byte	Red_4-6 - High Byte	
27	Red_2 - Low Byte	Red_2+5 - Low Byte	Red_4-6 - Low Byte	
28	Green_2 - High Byte	Green_2+5 - High Byte	Green_4-6 - High Byte	
29	Green_2 - Low Byte	Green_2+5 - Low Byte	Green_4-6 - Low Byte	
30	Blue_2 - High Byte	Blue_2+5 - High Byte	Blue_4-6 - High Byte	
31	Blue_2 - Low Byte	Blue_2+5 - Low Byte	Blue_4-6 - Low Byte	
32	White_2 - High Byte	White_2+5 - High Byte	White_4-6 - High Byte	
33	White_2 - Low Byte	White_2+5 - Low Byte	White_4-6 - Low Byte	
34	Zone 2 Red Strobe Duration	Zone 2+5 Red Strobe Duration	Zone 4-6 Red Strobe Duration	
35	Zone 2 Red Strobe Rate	Zone 2+5 Red Strobe Rate	Zone 4-6 Red Strobe Rate	
36	Zone 2 Green Strobe Duration	Zone 2+5 Green Strobe Duration	Zone 4-6 Green Strobe Duration	
37	Zone 2 Green Strobe Rate	Zone 2+5 Green Strobe Rate	Zone 4-6 Green Strobe Rate	
38	Zone 2 Blue Strobe Duration	Zone 2+5 Blue Strobe Duration	Zone 4-6 Blue Strobe Duration	
39	Zone 2 Blue Strobe Rate	Zone 2+5 Blue Strobe Rate	Zone 4-6 Blue Strobe Rate	
40	Zone 2 White Strobe Duration	Zone 2+5 White Strobe Duration	Zone 4-6 White Strobe Duration	
41	Zone 2 White Strobe Rate	Zone 2+5 White Strobe Rate	Zone 4-6 White Strobe Rate	
42	Zone 3 Intensity	Zone 3+6 Intensity		
43	Red_3 - High Byte	Red_3+6 - High Byte		
44	Red_3 - Low Byte	Red_3+6 - Low Byte		
45	Green_3 - High Byte	Green_3+6 - High Byte		
46	Green_3 - Low Byte	Green_3+6 - Low Byte		
47	Blue_3 - High Byte	Blue_3+6 - High Byte		
48	Blue_3 - Low Byte	Blue_3+6 - Low Byte		
49	White_3 - High Byte	White_3+6 - High Byte		
50	White_3 - Low Byte	White_3+6 - Low Byte		
51	Zone 3 Red Strobe Duration	Zone 3+6 Red Strobe Duration		
52	Zone 3 Red Strobe Rate	Zone 3+6 Red Strobe Rate		
53	Zone 3 Green Strobe Duration	Zone 3+6 Green Strobe Duration		
54	Zone 3 Green Strobe Rate	Zone 3+6 Green Strobe Rate		
55	Zone 3 Blue Strobe Duration	Zone 3+6 Blue Strobe Duration		
56	Zone 3 Blue Strobe Rate	Zone 3+6 Blue Strobe Rate		
57	Zone 3 White Strobe Duration	Zone 3+6 White Strobe Duration		
58	Zone 3 White Strobe Rate	Zone 3+6 White Strobe Rate		
59	Zone 4 Intensity			
60	Red_4 - High Byte			
61	Red_4 - Low Byte			
62	Green_4 - High Byte			
63	Green_4 - Low Byte			
64	Blue_4 - High Byte			
65	Blue_4 - Low Byte			
66	White_4 - High Byte			
67	White_4 - Low Byte			
68	Zone 4 Red Strobe Duration			
69	Zone 4 Red Strobe Rate			
70	Zone 4 Green Strobe Duration			
71	Zone 4 Green Strobe Rate			
72	Zone 4 Blue Strobe Duration			
73	Zone 4 Blue Strobe Rate			
74	Zone 4 White Strobe Duration			
75	Zone 4 White Strobe Rate			
76	Zone 5 Intensity			
77	Red_5 - High Byte			
78	Red_5 - Low Byte			
79	Green_5 - High Byte			
80	Green_5 - Low Byte			
81	Blue_5 - High Byte			
82	Blue_5 - Low Byte			
83	White_5 - High Byte			
84	White_5 - Low Byte			
85	Zone 5 Red Strobe Duration			
86	Zone 5 Red Strobe Rate			
87	Zone 5 Green Strobe Duration			
88	Zone 5 Green Strobe Rate			
89	Zone 5 Blue Strobe Duration			
90	Zone 5 Blue Strobe Rate			
91	Zone 5 White Strobe Duration			
92	Zone 5 White Strobe Rate			
93	Zone 6 Intensity			
94	Red_6 - High Byte			
95	Red_6 - Low Byte			
96	Green_6 - High Byte			
97	Green_6 - Low Byte			
98	Blue_6 - High Byte			
99	Blue_6 - Low Byte			
100	White_6 - High Byte			
101	White_6 - Low Byte			
102	Zone 6 Red Strobe Duration			
103	Zone 6 Red Strobe Rate			
104	Zone 6 Green Strobe Duration			
105	Zone 6 Green Strobe Rate			
106	Zone 6 Blue Strobe Duration			
107	Zone 6 Blue Strobe Rate			
108	Zone 6 White Strobe Duration			
109	Zone 6 White Strobe Rate			

Note: Refer to previous DMX mapping information for Color Presets, Strobe, Duration, Intensity Timing, Color Timing, and Control channels. Also, refer to "Mapping 16-Bit Mode" on page 44 for more information.

5. RGBW Expanded Mode

Table 13 provides DMX channel mapping of the DMX512 control values when the SL NITRO 510C LED STROBE Luminaire is in RGBW Expanded DMX512 mode (as set by the luminaire’s menu system).

Table 13: DMX Channel Mapping (RGBW Expanded Mode)

DMX Channel	Parameter	Range DMX	Range%	Default - recommended console default values	Description
1	Intensity - High Byte	0 - 65535	0 - 100%	0	16-bit control for the intensity of the LED settings - 0 to 65535 (full)
2	Intensity - Low Byte				
3	Color Presets	0 - 255	0 - 100%	0	<p><i>Select presets, variable color filters or chases as follows:</i></p> <p>Channel OFF (disabled) DMX 0 - 4 Preset 0 (OFF) DMX 5 - 6 Preset 1 DMX 7 - 8 Preset 2 DMX 9 - 10 Preset 3 DMX 11 - 12 Preset 4 DMX 13 - 14 Preset 5 DMX 15 - 16 Preset 6 DMX 17 - 18 Preset 7 DMX 19 - 20 Preset 8 DMX 21 - 22 Preset 9 DMX 23 - 24 Preset 10 DMX 25 - 26 Preset 11 DMX 27 - 28 Preset 12 DMX 29 - 30 Preset 13 DMX 31 - 32 Preset 14 DMX 33 - 34 Preset 15 DMX 35 - 36 Preset 16 DMX 37 - 38 Preset 17 DMX 39 - 40 Preset 18 DMX 41 - 42 Preset 19 DMX 43 - 44 Preset 20 DMX 45 - 46 Preset 21 DMX 47 - 48 Preset 22 DMX 49 - 50 Preset 23 DMX 51 - 52 Preset 24 DMX 53 - 54 Preset 25 DMX 55 - 56 Preset 26 DMX 57 - 58 Preset 27 DMX 59 - 60 Preset 28 DMX 61 - 62 Preset 29 DMX 63 - 64 Preset 30 DMX 65 - 66 Preset 31 DMX 67 - 68 CF_0_Color OFF DMX 69 - 70 CF_1_White 1000K DMX 71 - 72 CF_2_White 800K DMX 73 - 74 CF_3_White 6500K DMX 75 - 76 CF_4_White 5600K DMX 77 - 78 CF_5_White 5000K DMX 79 - 80 CF_6_White 4500K DMX 81 - 82 CF_7_White 4000K DMX 83 - 84 CF_8_White 3200K DMX 85 - 86 CF_9_White 3000K DMX 87 - 88 CF_10_White 2700K DMX 89 - 90 CF_11_Moroccan Pink DMX 91 - 92 CF_12_Pink DMX 93 - 94 CF_13_Flesh Pink DMX 95 - 96 CF_14_Bright Rose DMX 97 - 98 CF_15_Follies Pink DMX 99 - 100 CF_16_Fuchsia Pink DMX 101 - 102 CF_17_Surprise Pink DMX 103 - 104 CF_18_Congo Blue DMX 105 - 106 CF_19_Blue DMX 107 - 108 CF_20_Virgin Blue DMX 109 - 110 CF_21_Midnight Maya DMX 111 - 112 CF_22_Double C.T Blue DMX 113 - 114 CF_23_Slate Blue DMX 115 - 116 CF_24_Regal Blue DMX 117 - 118 CF_25_Full C.T Blue DMX 119 - 120 CF_26_Steel Blue DMX 121 - 122</p> <p>CONTINUED NEXT PAGE</p>

Table 13: DMX Channel Mapping (RGBW Expanded Mode)

3	Color Presets	0 - 255	0 - 100%	0	<p>CONTINUED FROM PREVIOUS PAGE</p> <p>CF_27_Lighter Blue DMX 123 - 124 CF_28_Cyan DMX 125 - 126 CF_29_Marine Blue DMX 127 - 128 CF_30_Soft Green DMX 129 - 130 CF_31_Moss Green DMX 131 - 132 CF_32_Green DMX 133 - 134 CF_33_Fem Green DMX 135 - 136 CF_34_JAS Green DMX 137 - 138 CF_35_Pale Green DMX 139 - 140 CF_36_Spring Yellow DMX 141 - 142 CF_37_Yellow DMX 143 - 144 CF_38_Deep Amber DMX 145 - 146 CF_39_Chrome Orange DMX 147 - 148 CF_40_Orange DMX 149 - 150 CF_41_Magenta DMX 151 - 152 CF_42_Flame Red DMX 153 - 154 CF_43_Purple DMX 155 - 156 Rotate CW Fast -> Slow DMX 157 - 171 Rotate ACW Slow -> Fast DMX 172 - 186 Random Color Fast -> Slow DMX 187 - 201</p> <p>Chase1 DMX 202 - 204 Chase2 DMX 205 - 207 Chase3 DMX 208 - 210 Chase4 DMX 211 - 213 Chase5 DMX 214 - 216 Chase6 DMX 217 - 219 Chase7 DMX 220 - 222 Chase8 DMX 223 - 225 Chase9 DMX 226 - 228 Chase10 DMX 229 - 231 User Chase1 DMX 232 - 234 User Chase2 DMX 235 - 237 User Chase3 DMX 238 - 240 User Chase4 DMX 241 - 243 User Chase5 DMX 244 - 246 User Chase6 DMX 247 - 249 User Chase7 DMX 250 - 252 User Chase8 DMX 253 - 255</p>
4	Strobe Effects	0 - 255	0 - 100%	0	<p>Controls strobe operation as follows:</p> <p>No Effect = DMX 0 - 5 (default) Ramp Up = DMX 6 - 42 Ramp Down = DMX 43 - 85 Ramp up/down = DMX 86 - 128 Random = DMX 129 - 171 Top row only = DMX 172 - 173 Bottom row only = DMX 174 - 175 Left zone only = DMX 176 - 178 Center zone only = DMX 179 - 180 Right zone only = DMX 181 - 182 Checker pattern A = DMX 183 - 184 Checker pattern B = DMX 185 - 186 Random zones = DMX 187 - 214 Circle zone chase CW = DMX 215 - 235 Circle zone chase CCW = DMX 236 - 255</p>
5	Intensity Timing	0 - 255	0 - 100%	255	<p>Allows for timing control of intensity. Channel should default to 255 for smoothest actions using console and/or manual fades.</p>
6	Color Timing	0 - 255	0 - 100%	255	<p>Allows for timing control of color parameters. Channel should default to 255 for smoothest actions using console and/or manual fades.</p>

Table 13: DMX Channel Mapping (RGBW Expanded Mode)

7	Control Channel	0 - 255	0 - 100%	0	<p>Control channel operation. Set control channel value to desired action, hold value for at least 5 seconds, then turn to 0. Set control channel value to 0 without any scaling.</p> <p>Default Setting on Console = DMX 0-4 Dimming Curve_linear = DMX 30 - 34 Dimming Curve_Square = DMX 35- 39 Dimming Curve_S-Curve = DMX 40 - 44 Dimming Curve_PL-Curve = DMX 45 - 49 Calibration_OFF = DMX 70 - 74 Calibration_ON = DMX 75 - 79 Fan_Auto = DMX 80 - 84 Fan_Off = DMX 85 - 89</p> <p><i>The following is only available for "Zones Mapping" protocol. The following is instantly applied and DOES NOT require the 5 second hold.</i></p> <p>Combined zone control - (all zones follow zone 1 setting) = DMX 100 - 104</p> <p><i>The following is only available for "2 Zones Modes". The following is instantly applied and does not require the 5 second hold:</i> Linear Pattern = DMX 105 - 108* Checker Pattern = 109 - 112* *See Figure 17.</p> <p>Not Used = DMX 113 - 250 (<i>Reserved for future use</i>)</p>
8	Zone 1 - 6 Intensity	0 - 255	0 - 100%	0	8-bit control for the intensity of the Zones - 0 to 255 (full)
9	Red 1 - 6 - High	0 - 65535	0 - 100%	0	16-bit control of Red LEDs from 0 to full
10	Red 1 - 6 - Low				
11	Green 1 - 6 - High	0 - 65535	0 - 100%	0	16-bit control of Green LEDs from 0 to full
12	Green 1 - 6 - Low				
13	Blue 1 - 6 - High	0 - 65535	0 - 100%	0	16-bit control of Blue LEDs from 0 to full
14	Blue 1 - 6 - Low				
15	White 1 - 6 - High	0 - 65535	0 - 100%	0	16-bit control of White LEDs from 0 to full
16	White 1 - 6 - Low				
17	Zone 1 - 6 RGB Strobe Duration	0 - 255	0 - 100%	0	Controls strobe duration of RGB LEDs only. Refer to "Strobe Duration DMX Timing Detail" on page 47.
18	Zone 1 - 6 RGB Strobe Rate	0 - 255	0 - 100%	0	Controls strobe rate operation RGB LEDs only. Refer to "Strobe Rate DMX Timing Detail" on page 46.
19	Zone 1 - 6 White Strobe Duration	0 - 255	0 - 100%	0	Controls strobe duration of White LEDs only. Refer to "Strobe Duration DMX Timing Detail" on page 47.
20	Zone 1 - 6 White Strobe Rate	0 - 255	0 - 100%	0	Controls strobe rate operation of White LEDs only. Refer to "Strobe Rate DMX Timing Detail" on page 46.

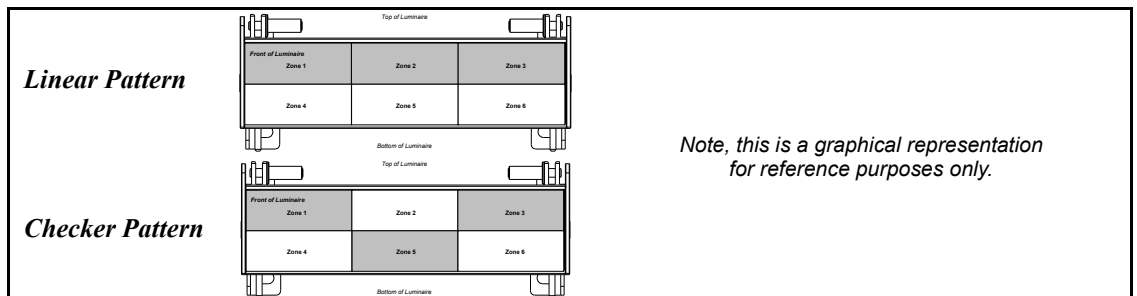

Figure 17: Linear & Checker Pattern

6. RGBW Expanded Mode (Zones)

Table 14 provides DMX channel mapping of all DMX512 control values when the SL NITRO 510C LED STROBE Luminaire is operated in various Groups (Zones) Control Mode when set to RGBW Expanded Mode.

Table 14: DMX Channel Mapping (RGBW Expanded Group Modes)

DMX CHANNEL	RGBW EXPANDED MODE			
	6 Zone MODE	3 Zone MODE	2 Zone MODE	1 Zone MODE
1	Master Intensity - High	Master Intensity - High	Master Intensity - High	Master Intensity - High
2	Master Intensity - Low	Master Intensity - Low	Master Intensity - Low	Master Intensity - Low
3	Color Presets	Color Presets	Color Presets	Color Presets
4	Effects	Effects	Effects	Effects
5	Intensity Timing	Intensity Timing	Intensity Timing	Intensity Timing
6	Color Timing	Color Timing	Color Timing	Color Timing
7	Control	Control	Control	Control
8	Zone 1 Intensity	Zone 1+4 Intensity	Zone 1-3 Intensity	Zone 1-6 Intensity
9	Red_1 - High Byte	Red_1+4 - High Byte	Red_1-3 - High Byte	Red_1-6 - High Byte
10	Red_1 - Low Byte	Red_1+4 - Low Byte	Red_1-3 - Low Byte	Red_1-6 - Low Byte
11	Green_1 - High Byte	Green_1+4 - High Byte	Green_1-3 - High Byte	Green_1-6 - High Byte
12	Green_1 - Low Byte	Green_1+4 - Low Byte	Green_1-3 - Low Byte	Green_1-6 - Low Byte
13	Blue_1 - High Byte	Blue_1+4 - High Byte	Blue_1-3 - High Byte	Blue_1-6 - High Byte
14	Blue_1 - Low Byte	Blue_1+4 - Low Byte	Blue_1-3 - Low Byte	Blue_1-6 - Low Byte
15	White_1 - High Byte	White_1+4 - High Byte	White_1-3 - High Byte	White_1-6 - High Byte
16	White_1 - Low Byte	White_1+4 - Low Byte	White_1-3 - Low Byte	White_1-6 - Low Byte
17	Zone 1 RGB Strobe Duration	Zone 1+4 RGB Strobe Duration	Zone 1-3 RGB Strobe Duration	Zone 1-6 RGB Strobe Duration
18	Zone 1 RGB Strobe Rate	Zone 1+4 RGB Strobe Rate	Zone 1-3 RGB Strobe Rate	Zone 1-6 RGB Strobe Rate
19	Zone 1 White Strobe Duration	Zone 1+4 White Strobe Duration	Zone 1-3 White Strobe Duration	Zone 1-6 White Strobe Duration
20	Zone 1 White Strobe Rate	Zone 1+4 White Strobe Rate	Zone 1-3 White Strobe Rate	Zone 1-6 White Strobe Rate
21	Zone 2 Intensity	Zone 2+5 Intensity	Zone 4-6 Intensity	
22	Red_2 - High Byte	Red_2+5 - High Byte	Red_4-6 - High Byte	
23	Red_2 - Low Byte	Red_2+5 - Low Byte	Red_4-6 - Low Byte	
24	Green_2 - High Byte	Green_2+5 - High Byte	Green_4-6 - High Byte	
25	Green_2 - Low Byte	Green_2+5 - Low Byte	Green_4-6 - Low Byte	
26	Blue_2 - High Byte	Blue_2+5 - High Byte	Blue_4-6 - High Byte	
27	Blue_2 - Low Byte	Blue_2+5 - Low Byte	Blue_4-6 - Low Byte	
28	White_2 - High Byte	White_2+5 - High Byte	White_4-6 - High Byte	
29	White_2 - Low Byte	White_2+5 - Low Byte	White_4-6 - Low Byte	
30	Zone 2 RGB Strobe Duration	Zone 2+5 RGB Strobe Duration	Zone 4-6 RGB Strobe Duration	
31	Zone 2 RGB Strobe Rate	Zone 2+5 RGB Strobe Rate	Zone 4-6 RGB Strobe Rate	
32	Zone 2 White Strobe Duration	Zone 2+5 White Strobe Duration	Zone 4-6 White Strobe Duration	
33	Zone 2 White Strobe Rate	Zone 2+5 White Strobe Rate	Zone 4-6 White Strobe Rate	
34	Zone 3 Intensity	Zone 3+6 Intensity		
35	Red_3 - High Byte	Red_3+6 - High Byte		
36	Red_3 - Low Byte	Red_3+6 - Low Byte	*Note: zone pattern depends on control channel setting	
37	Green_3 - High Byte	Green_3+6 - High Byte		
38	Green_3 - Low Byte	Green_3+6 - Low Byte		
39	Blue_3 - High Byte	Blue_3+6 - High Byte		
40	Blue_3 - Low Byte	Blue_3+6 - Low Byte		
41	White_3 - High Byte	White_3+6 - High Byte		
42	White_3 - Low Byte	White_3+6 - Low Byte		
43	Zone 3 RGB Strobe Duration	Zone 3+6 RGB Strobe Duration		
44	Zone 3 RGB Strobe Rate	Zone 3+6 RGB Strobe Rate		
45	Zone 3 White Strobe Duration	Zone 3+6 White Strobe Duration		
46	Zone 3 White Strobe Rate	Zone 3+6 White Strobe Rate		
47	Zone 4 Intensity			
48	Red_4 - High Byte			
49	Red_4 - Low Byte			
50	Green_4 - High Byte			
51	Green_4 - Low Byte			
52	Blue_4 - High Byte			
53	Blue_4 - Low Byte			
54	White_4 - High Byte			
55	White_4 - Low Byte			
56	Zone 4 RGB Strobe Duration			
57	Zone 4 RGB Strobe Rate			
58	Zone 4 White Strobe Duration			
59	Zone 4 White Strobe Rate			
60	Zone 5 Intensity			
61	Red_5 - High Byte			
62	Red_5 - Low Byte			
63	Green_5 - High Byte			
64	Green_5 - Low Byte			
65	Blue_5 - High Byte			
66	Blue_5 - Low Byte			
67	White_5 - High Byte			
68	White_5 - Low Byte			
69	Zone 5 RGB Strobe Duration			
70	Zone 5 RGB Strobe Rate			
71	Zone 5 White Strobe Duration			
72	Zone 5 White Strobe Rate			
73	Zone 6 Intensity			
74	Red_6 - High Byte			
75	Red_6 - Low Byte			
76	Green_6 - High Byte			
77	Green_6 - Low Byte			
78	Blue_6 - High Byte			
79	Blue_6 - Low Byte			
80	White_6 - High Byte			
81	White_6 - Low Byte			
82	Zone 6 RGB Strobe Duration			
83	Zone 6 RGB Strobe Rate			
84	Zone 6 White Strobe Duration			
85	Zone 6 White Strobe Rate			

Note: Refer to previous DMX mapping information for Color Presets, Strobe, Duration, Intensity Timing, Color Timing, and Control channels. Also, refer to "[Mapping 16-Bit Mode](#)" on page 44 for more information.

7. RGBW 16-Bit Mode

Table 15 provides DMX channel mapping of the DMX512 control values when the SL NITRO 510C LED STROBE Luminaire is in RGBW 16-Bit DMX512 mode (as set by the luminaire's menu system).

Table 15: DMX Channel Mapping (RGBW 16-Bit Mode)

DMX Channel	Parameter	Range DMX	Range%	Default - recommended console default values	Description
1	Intensity - High Byte	0 - 65535	0 - 100%	0	16-bit control for the intensity of the LED settings - 0 to 65535 (full)
2	Intensity - Low Byte				
3	Color Presets	0 - 255	0 - 100%	0	<p>Select presets, variable color filters or chases as follows:</p> <p>Channel OFF (disabled) DMX 0 - 4 Preset 0 (OFF) DMX 5 - 6 Preset 1 DMX 7 - 8 Preset 2 DMX 9 - 10 Preset 3 DMX 11 - 12 Preset 4 DMX 13 - 14 Preset 5 DMX 15 - 16 Preset 6 DMX 17 - 18 Preset 7 DMX 19 - 20 Preset 8 DMX 21 - 22 Preset 9 DMX 23 - 24 Preset 10 DMX 25 - 26 Preset 11 DMX 27 - 28 Preset 12 DMX 29 - 30 Preset 13 DMX 31 - 32 Preset 14 DMX 33 - 34 Preset 15 DMX 35 - 36 Preset 16 DMX 37 - 38 Preset 17 DMX 39 - 40 Preset 18 DMX 41 - 42 Preset 19 DMX 43 - 44 Preset 20 DMX 45 - 46 Preset 21 DMX 47 - 48 Preset 22 DMX 49 - 50 Preset 23 DMX 51 - 52 Preset 24 DMX 53 - 54 Preset 25 DMX 55 - 56 Preset 26 DMX 57 - 58 Preset 27 DMX 59 - 60 Preset 28 DMX 61 - 62 Preset 29 DMX 63 - 64 Preset 30 DMX 65 - 66 Preset 31 DMX 67 - 68 CF_0_Color OFF DMX 69 - 70 CF_1_White 1000K DMX 71 - 72 CF_2_White 8000K DMX 73 - 74 CF_3_White 6500K DMX 75 - 76 CF_4_White 5600K DMX 77 - 78 CF_5_White 5000K DMX 79 - 80 CF_6_White 4500K DMX 81 - 82 CF_7_White 4000K DMX 83 - 84 CF_8_White 3200K DMX 85 - 86 CF_9_White 3000K DMX 87 - 88 CF_10_White 2700K DMX 89 - 90 CF_11_Moroccan Pink DMX 91 - 92 CF_12_Pink DMX 93 - 94 CF_13_Flesh Pink DMX 95 - 96 CF_14_Bright Rose DMX 97 - 98 CF_15_Follies Pink DMX 99 - 100 CF_16_Fuchsia Pink DMX 101 - 102 CF_17_Surprise Pink DMX 103 - 104 CF_18_Congo Blue DMX 105 - 106 CF_19_Blue DMX 107 - 108 CF_20_Virgin Blue DMX 109 - 110 CF_21_Midnight Maya DMX 111 - 112 CF_22_Double C.T Blue DMX 113 - 114 CF_23_Slate Blue DMX 115 - 116 CF_24_Regal Blue DMX 117 - 118 CF_25_Full C.T Blue DMX 119 - 120 CF_26_Steel Blue DMX 121 - 122</p> <p>CONTINUED NEXT PAGE</p>

Table 15: DMX Channel Mapping (RGBW 16-Bit Mode)

3	Color Presets	0 - 255	0 - 100%	0	<p>CONTINUED FROM PREVIOUS PAGE</p> <p>CF_27_Lighter Blue DMX 123 - 124 CF_28_Cyan DMX 125 - 126 CF_29_Marine Blue DMX 127 - 128 CF_30_Soft Green DMX 129 - 130 CF_31_Moss Green DMX 131 - 132 CF_32_Green DMX 133 - 134 CF_33_Fem Green DMX 135 - 136 CF_34_JAS Green DMX 137 - 138 CF_35_Pale Green DMX 139 - 140 CF_36_Spring Yellow DMX 141 - 142 CF_37_Yellow DMX 143 - 144 CF_38_Deep Amber DMX 145 - 146 CF_39_Chrome Orange DMX 147 - 148 CF_40_Orange DMX 149 - 150 CF_41_Magenta DMX 151 - 152 CF_42_Flame Red DMX 153 - 154 CF_43_Purple DMX 155 - 156 Rotate CW Fast -> Slow DMX 157 - 171 Rotate ACW Slow -> Fast DMX 172 - 186 Random Color Fast -> Slow DMX 187 - 201</p> <p>Chase1 DMX 202 - 204 Chase2 DMX 205 - 207 Chase3 DMX 208 - 210 Chase4 DMX 211 - 213 Chase5 DMX 214 - 216 Chase6 DMX 217 - 219 Chase7 DMX 220 - 222 Chase8 DMX 223 - 225 Chase9 DMX 226 - 228 Chase10 DMX 229 - 231 User Chase1 DMX 232 - 234 User Chase2 DMX 235 - 237 User Chase3 DMX 238 - 240 User Chase4 DMX 241 - 243 User Chase5 DMX 244 - 246 User Chase6 DMX 247 - 249 User Chase7 DMX 250 - 252 User Chase8 DMX 253 - 255</p>
4	Strobe Effects	0 - 255	0 - 100%	0	<p>Controls strobe operation as follows:</p> <p>No Effect = DMX 0 - 5 (default) Ramp Up = DMX 6 - 42 Ramp Down = DMX 43 - 85 Ramp up/down = DMX 86 - 128 Random = DMX 129 - 171 Top row only = DMX 172 - 173 Bottom row only = DMX 174 - 175 Left zone only = DMX 176 - 178 Center zone only = DMX 179 - 180 Right zone only = DMX 181 - 182 Checker pattern A = DMX 183 - 184 Checker pattern B = DMX 185 - 186 Random zones = DMX 187 - 214 Circle zone chase CW = DMX 215 - 235 Circle zone chase CCW = DMX 236 - 255</p>
5	Intensity Timing	0 - 255	0 - 100%	255	<p>Allows for timing control of intensity. Channel should default to 255 for smoothest actions using console and/or manual fades.</p>
6	Color Timing	0 - 255	0 - 100%	255	<p>Allows for timing control of color parameters. Channel should default to 255 for smoothest actions using console and/or manual fades.</p>

Table 15: DMX Channel Mapping (RGBW 16-Bit Mode)

7	Control Channel	0 - 255	0 - 100%	0	<p>Control channel operation. Set control channel value to desired action, hold value for at least 5 seconds, then turn to 0. Set control channel value to 0 without any scaling.</p> <p>Default Setting on Console = DMX 0-4 Dimming Curve_linear = DMX 30 - 34 Dimming Curve_Square = DMX 35- 39 Dimming Curve_S-Curve = DMX 40 - 44 Dimming Curve_PL-Curve = DMX 45 - 49 Calibration_OFF = DMX 70 - 74 Calibration_ON = DMX 75 - 79 Fan_Auto = DMX 80 - 84 Fan_Off = DMX 85 - 89</p> <p><i>The following is only available for "Zones Mapping" protocol. The following is instantly applied and DOES NOT require the 5 second hold.</i></p> <p>Combined zone control - (all zones follow zone 1 setting) = DMX 100 - 104</p> <p><i>The following is only available for "2 Zones Modes". The following is instantly applied and does not require the 5 second hold:</i> Linear Pattern = DMX 105 - 108* Checker Pattern = 109 - 112* *See Figure 18.</p> <p>Not Used = DMX 113 - 250 (<i>Reserved for future use</i>)</p>
8	Zone 1 - 6 Intensity	0 - 255	0 - 100%	0	8-bit control for the intensity of the Zones - 0 to 255 (full)
9	Red 1 - 6 - High	0 - 65535	0 - 100%	0	16-bit control of Red LEDs from 0 to full
10	Red 1 - 6 - Low				
11	Green 1 - 6 - High	0 - 65535	0 - 100%	0	16-bit control of Green LEDs from 0 to full
12	Green 1 - 6 - Low				
13	Blue 1 - 6 - High	0 - 65535	0 - 100%	0	16-bit control of Blue LEDs from 0 to full
14	Blue 1 - 6 - Low				
15	White 1 - 6 - High	0 - 65535	0 - 100%	0	16-bit control of White LEDs from 0 to full
16	White 1 - 6 - Low				
17	Zone 1 - 6 Strobe Duration	0 - 255	0 - 100%	0	Controls strobe duration. Refer to "Strobe Duration DMX Timing Detail" on page 47.
18	Zone 1 - 6 Strobe Rate	0 - 255	0 - 100%	0	Controls strobe rate operation. Refer to "Strobe Rate DMX Timing Detail" on page 46.

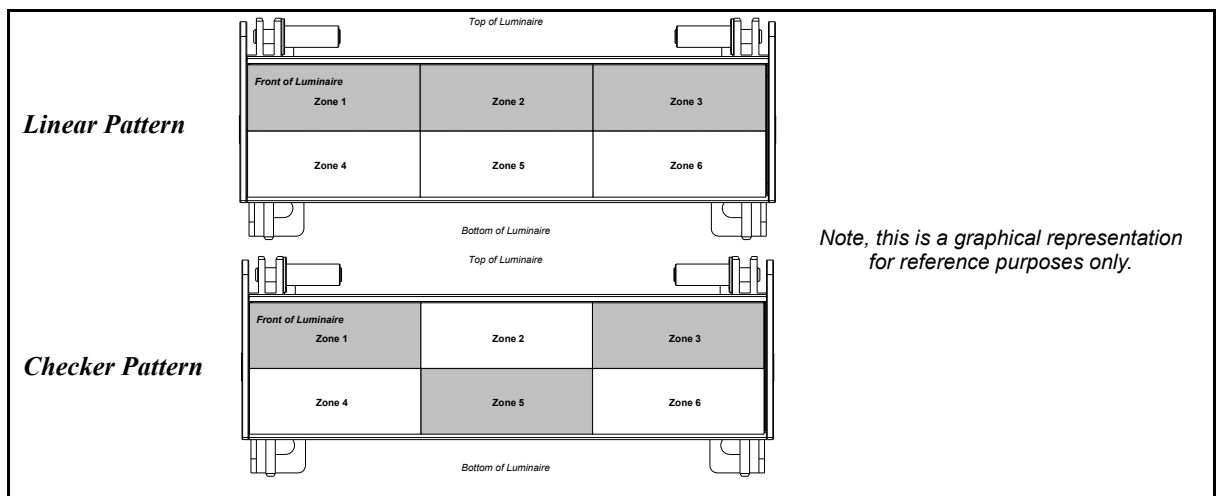

Figure 18: Linear & Checker Pattern

8. RGBW 16-Bit Mode (Zones)

Table 16 provides DMX channel mapping of all DMX512 control values when the SL NITRO 510C LED STROBE Luminaire is operated in various Groups (Zones) Control Mode when set to RGBW 16-Bit Mode.

Table 16: DMX Channel Mapping (RGBW 16-Bit Group Modes)

RGBW 16 BIT MODE				
DMX CHANNEL	6 Zone MODE	3 Zone MODE	2 Zone MODE	1 Zone MODE
1	Master Intensity - High	Master Intensity - High	Master Intensity - High	Master Intensity - High
2	Master Intensity - Low	Master Intensity - Low	Master Intensity - Low	Master Intensity - Low
3	Color Presets	Color Presets	Color Presets	Color Presets
4	Effects	Effects	Effects	Effects
5	Intensity Timing	Intensity Timing	Intensity Timing	Intensity Timing
6	Color Timing	Color Timing	Color Timing	Color Timing
7	Control	Control	Control	Control
8	Zone 1 Intensity	Zone 1+4 Intensity	Zone 1-3 Intensity	Zone 1-6 Intensity
9	Red_1 - High Byte	Red_1+4 - High Byte	Red_1-3 - High Byte	Red_1-6 - High Byte
10	Red_1 - Low Byte	Red_1+4 - Low Byte	Red_1-3 - Low Byte	Red_1-6 - Low Byte
11	Green_1 - High Byte	Green_1+4 - High Byte	Green_1-3 - High Byte	Green_1-6 - High Byte
12	Green_1 - Low Byte	Green_1+4 - Low Byte	Green_1-3 - Low Byte	Green_1-6 - Low Byte
13	Blue_1 - High Byte	Blue_1+4 - High Byte	Blue_1-3 - High Byte	Blue_1-6 - High Byte
14	Blue_1 - Low Byte	Blue_1+4 - Low Byte	Blue_1-3 - Low Byte	Blue_1-6 - Low Byte
15	White_1 - High Byte	White_1+4 - High Byte	White_1-3 - High Byte	White_1-6 - High Byte
16	White_1 - Low Byte	White_1+4 - Low Byte	White_1-3 - Low Byte	White_1-6 - Low Byte
17	Zone 1 Strobe Duration	Zone 1+4 Strobe Duration	Zone 1-3 Strobe Duration	Zone 1-6 Strobe Duration
18	Zone 1 Strobe Rate	Zone 1+4 Strobe Rate	Zone 1-3 Strobe Rate	Zone 1-6 Strobe Rate
19	Zone 2 Intensity	Zone 2+5 Intensity	Zone 4-6 Intensity	
20	Red_2 - High Byte	Red_2+5 - High Byte	Red_4-6 - High Byte	
21	Red_2 - Low Byte	Red_2+5 - Low Byte	Red_4-6 - Low Byte	
22	Green_2 - High Byte	Green_2+5 - High Byte	Green_4-6 - High Byte	
23	Green_2 - Low Byte	Green_2+5 - Low Byte	Green_4-6 - Low Byte	
24	Blue_2 - High Byte	Blue_2+5 - High Byte	Blue_4-6 - High Byte	
25	Blue_2 - Low Byte	Blue_2+5 - Low Byte	Blue_4-6 - Low Byte	
26	White_2 - High Byte	White_2+5 - High Byte	White_4-6 - High Byte	
27	White_2 - Low Byte	White_2+5 - Low Byte	White_4-6 - Low Byte	
28	Zone 2 Strobe Duration	Zone 2+5 Strobe Duration	Zone 4-6 Strobe Duration	
29	Zone 2 Strobe Rate	Zone 2+5 Strobe Rate	Zone 4-6 Strobe Rate	
30	Zone 3 Intensity	Zone 3+6 Intensity		
31	Red_3 - High Byte	Red_3+6 - High Byte		
32	Red_3 - Low Byte	Red_3+6 - Low Byte	*Note: zone pattern depends on control channel setting	
33	Green_3 - High Byte	Green_3+6 - High Byte		
34	Green_3 - Low Byte	Green_3+6 - Low Byte		
35	Blue_3 - High Byte	Blue_3+6 - High Byte		
36	Blue_3 - Low Byte	Blue_3+6 - Low Byte		
37	White_3 - High Byte	White_3+6 - High Byte		
38	White_3 - Low Byte	White_3+6 - Low Byte		
39	Zone 3 Strobe Duration	Zone 3+6 Strobe Duration		
40	Zone 3 Strobe Rate	Zone 3+6 Strobe Rate		
41	Zone 4 Intensity			
42	Red_4 - High Byte			
43	Red_4 - Low Byte			
44	Green_4 - High Byte			
45	Green_4 - Low Byte			
46	Blue_4 - High Byte			
47	Blue_4 - Low Byte			
48	White_4 - High Byte			
49	White_4 - Low Byte			
50	Zone 4 Strobe Duration			
51	Zone 4 Strobe Rate			
52	Zone 5 Intensity			
53	Red_5 - High Byte			
54	Red_5 - Low Byte			
55	Green_5 - High Byte			
56	Green_5 - Low Byte			
57	Blue_5 - High Byte			
58	Blue_5 - Low Byte			
59	White_5 - High Byte			
60	White_5 - Low Byte			
61	Zone 5 Strobe Duration			
62	Zone 5 Strobe Rate			
63	Zone 6 Intensity			
64	Red_6 - High Byte			
65	Red_6 - Low Byte			
66	Green_6 - High Byte			
67	Green_6 - Low Byte			
68	Blue_6 - High Byte			
69	Blue_6 - Low Byte			
70	White_6 - High Byte			
71	White_6 - Low Byte			
72	Zone 6 Strobe Duration			
73	Zone 6 Strobe Rate			

Note: Refer to previous DMX mapping information for Color Presets, Strobe, Duration, Intensity Timing, Color Timing, and Control channels. Also, refer to "Mapping 16-Bit Mode" on page 44 for more information.

9. RGBW 8-Bit Mode

Table 15 provides DMX channel mapping of the DMX512 control values when the SL NITRO 510C LED STROBE Luminaire is in RGBW 8-Bit DMX512 mode (as set by the luminaire’s menu system).

Table 17: DMX Channel Mapping (RGBW 8-Bit Mode)

DMX Channel	Parameter	Range DMX	Range%	Default - recommended console default values	Description
1	Master Intensity	0 - 255	0 - 100%	0	8-bit control for the intensity of the LED settings - 0 to 255 (full)
2	Color Presets	0 - 255	0 - 100%	0	<p>Select presets, variable color filters or chases as follows:</p> <p>Channel OFF (disabled) DMX 0 - 4 Preset 0 (OFF) DMX 5 - 6 Preset 1 DMX 7 - 8 Preset 2 DMX 9 - 10 Preset 3 DMX 11 - 12 Preset 4 DMX 13 - 14 Preset 5 DMX 15 - 16 Preset 6 DMX 17 - 18 Preset 7 DMX 19 - 20 Preset 8 DMX 21 - 22 Preset 9 DMX 23 - 24 Preset 10 DMX 25 - 26 Preset 11 DMX 27 - 28 Preset 12 DMX 29 - 30 Preset 13 DMX 31 - 32 Preset 14 DMX 33 - 34 Preset 15 DMX 35 - 36 Preset 16 DMX 37 - 38 Preset 17 DMX 39 - 40 Preset 18 DMX 41 - 42 Preset 19 DMX 43 - 44 Preset 20 DMX 45 - 46 Preset 21 DMX 47 - 48 Preset 22 DMX 49 - 50 Preset 23 DMX 51 - 52 Preset 24 DMX 53 - 54 Preset 25 DMX 55 - 56 Preset 26 DMX 57 - 58 Preset 27 DMX 59 - 60 Preset 28 DMX 61 - 62 Preset 29 DMX 63 - 64 Preset 30 DMX 65 - 66 Preset 31 DMX 67 - 68 CF_0_Color OFF DMX 69 - 70 CF_1_White 10000K DMX 71 - 72 CF_2_White 8000K DMX 73 - 74 CF_3_White 6500K DMX 75 - 76 CF_4_White 5600K DMX 77 - 78 CF_5_White 5000K DMX 79 - 80 CF_6_White 4500K DMX 81 - 82 CF_7_White 4000K DMX 83 - 84 CF_8_White 3200K DMX 85 - 86 CF_9_White 3000K DMX 87 - 88 CF_10_White 2700K DMX 89 - 90 CF_11_Moroccan Pink DMX 91 - 92 CF_12_Pink DMX 93 - 94 CF_13_Flesh Pink DMX 95 - 96 CF_14_Bright Rose DMX 97 - 98 CF_15_Follies Pink DMX 99 - 100 CF_16_Fuchsia Pink DMX 101 - 102 CF_17_Surprise Pink DMX 103 - 104 CF_18_Congo Blue DMX 105 - 106 CF_19_Blue DMX 107 - 108 CF_20_Virgin Blue DMX 109 - 110 CF_21_Midnight Maya DMX 111 - 112 CF_22_Double C.T Blue DMX 113 - 114 CF_23_Slate Blue DMX 115 - 116 CF_24_Regal Blue DMX 117 - 118 CF_25_Full C.T Blue DMX 119 - 120 CF_26_Steel Blue DMX 121 - 122</p> <p>CONTINUED NEXT PAGE</p>

Table 17: DMX Channel Mapping (RGBW 8-Bit Mode)

2	Color Presets	0 - 255	0 - 100%	0	<p>CONTINUED FROM PREVIOUS PAGE</p> <p>CF_27_Lighter Blue DMX 123 - 124 CF_28_Cyan DMX 125 - 126 CF_29_Marine Blue DMX 127 - 128 CF_30_Soft Green DMX 129 - 130 CF_31_Moss Green DMX 131 - 132 CF_32_Green DMX 133 - 134 CF_33_Fem Green DMX 135 - 136 CF_34_JAS Green DMX 137 - 138 CF_35_Pale Green DMX 139 - 140 CF_36_Spring Yellow DMX 141 - 142 CF_37_Yellow DMX 143 - 144 CF_38_Deep Amber DMX 145 - 146 CF_39_Chrome Orange DMX 147 - 148 CF_40_Orange DMX 149 - 150 CF_41_Magenta DMX 151 - 152 CF_42_Flame Red DMX 153 - 154 CF_43_Purple DMX 155 - 156 Rotate CW Fast -> Slow DMX 157 - 171 Rotate ACW Slow -> Fast DMX 172 - 186 Random Color Fast -> Slow DMX 187 - 201</p> <p>Chase1 DMX 202 - 204 Chase2 DMX 205 - 207 Chase3 DMX 208 - 210 Chase4 DMX 211 - 213 Chase5 DMX 214 - 216 Chase6 DMX 217 - 219 Chase7 DMX 220 - 222 Chase8 DMX 223 - 225 Chase9 DMX 226 - 228 Chase10 DMX 229 - 231 User Chase1 DMX 232 - 234 User Chase2 DMX 235 - 237 User Chase3 DMX 238 - 240 User Chase4 DMX 241 - 243 User Chase5 DMX 244 - 246 User Chase6 DMX 247 - 249 User Chase7 DMX 250 - 252 User Chase8 DMX 253 - 255</p>
3	Strobe Effects	0 - 255	0 - 100%	0	<p>Controls strobe operation as follows:</p> <p>No Effect = DMX 0 - 5 (default) Ramp Up = DMX 6 - 42 Ramp Down = DMX 43 - 85 Ramp up/down = DMX 86 - 128 Random = DMX 129 - 171 Top row only = DMX 172 - 173 Bottom row only = DMX 174 - 175 Left zone only = DMX 176 - 178 Center zone only = DMX 179 - 180 Right zone only = DMX 181 - 182 Checker pattern A = DMX 183 - 184 Checker pattern B = DMX 185 - 186 Random zones = DMX 187 - 214 Circle zone chase CW = DMX 215 - 235 Circle zone chase CCW = DMX 236 - 255</p>
4	Timing	0 - 255	0 - 100%	255	<p>Allows for timing control of intensity and color. Channel should default to 255 for smoothest actions using console and/or manual fades.</p>

Table 17: DMX Channel Mapping (RGBW 8-Bit Mode)

5	Control Channel	0 - 255	0 - 100%	0	<p>Control channel operation. Set control channel value to desired action, hold value for at least 5 seconds, then turn to 0. Set control channel value to 0 without any scaling.</p> <p>Default Setting on Console = DMX 0-4 Dimming Curve_linear = DMX 30 - 34 Dimming Curve_Square = DMX 35- 39 Dimming Curve_S-Curve = DMX 40 - 44 Dimming Curve_PL-Curve = DMX 45 - 49 Calibration_OFF = DMX 70 - 74 Calibration_ON = DMX 75 - 79 Fan_Auto = DMX 80 - 84 Fan_Off = DMX 85 - 89</p> <p><i>The following is only available for "Zones Mapping" protocol. The following is instantly applied and DOES NOT require the 5 second hold.</i></p> <p>Combined zone control - (all zones follow zone 1 setting) = DMX 100 - 104</p> <p><i>The following is only available for "2 Zones Modes". The following is instantly applied and does not require the 5 second hold:</i> Linear Pattern = DMX 105 - 108* Checker Pattern = 109 - 112* *See Figure 19.</p> <p>Not Used = DMX 113 - 250 (<i>Reserved for future use</i>)</p>
6	Zone 1 - 6 Intensity	0 - 255	0 - 100%	0	8-bit control for the intensity of the Zones - 0 to 255 (full)
7	Red 1 - 6	0 - 255	0 - 100%	0	8-bit control of Red LEDs from 0 to full
8	Green 1 - 6	0 - 255	0 - 100%	0	8-bit control of Green LEDs from 0 to full
9	Blue 1 - 6	0 - 255	0 - 100%	0	8-bit control of Blue LEDs from 0 to full
10	White 1 - 6	0 - 255	0 - 100%	0	8-bit control of White LEDs from 0 to full
11	Zone 1 - 6 Strobe Duration	0 - 255	0 - 100%	0	Controls strobe duration. Refer to "Strobe Duration DMX Timing Detail" on page 47.
12	Zone 1 - 6 Strobe Rate	0 - 255	0 - 100%	0	Controls strobe rate operation. Refer to "Strobe Rate DMX Timing Detail" on page 46.

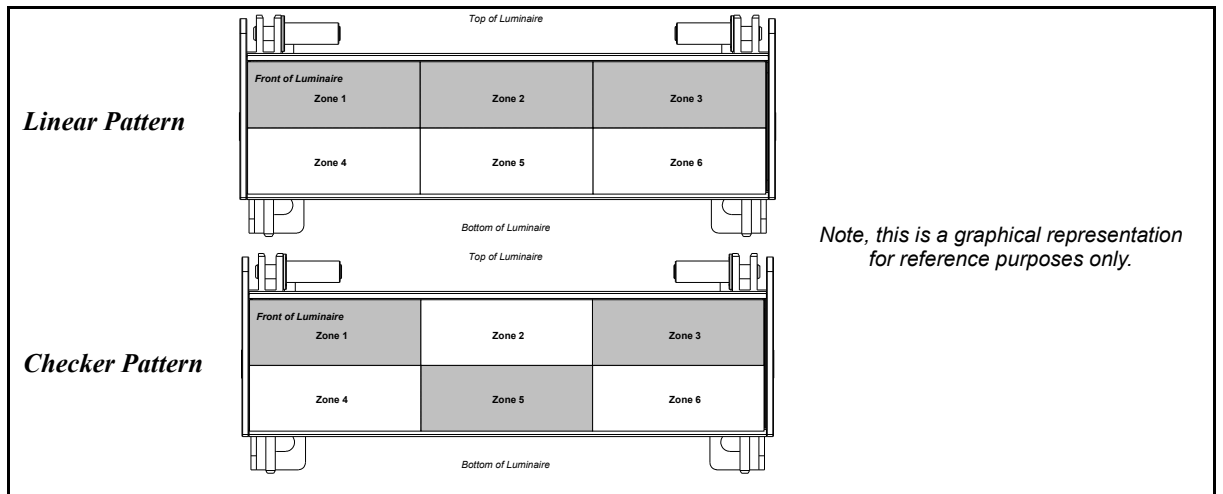

Figure 19: Linear & Checker Pattern

10. RGBW 8-Bit Mode (Zones)

Table 18 provides DMX channel mapping of all DMX512 control values when the SL NITRO 510C LED STROBE Luminaire is operated in various Groups (Zones) Control Mode when set to RGBW 8-Bit Mode.

Table 18: DMX Channel Mapping (RGBW 8-Bit Group Modes)

RGBW 8 BIT MODE				
DMX CHANNEL	6 Zone MODE	3 Zone MODE	2 Zone MODE	1 Zone MODE
1	Master Intensity	Master Intensity	Master Intensity	Master Intensity
2	Color Presets	Color Presets	Color Presets	Color Presets
3	Effects	Effects	Effects	Effects
4	Timing	Timing	Timing	Timing
5	Control	Control	Control	Control
6	Zone 1 Intensity	Zone 1+4 Intensity	Zone 1-3 Intensity	Zone 1-6 Intensity
7	Red_1	Red_1+4	Red_1-3	Red_1-6 - High Byte
8	Green_1	Green_1+4	Green_1-3	Green_1-6 - High Byte
9	Blue_1	Blue_1+4	Blue_1-3	Blue_1-6 - High Byte
10	White_1	White_1+4	White_1-3	White_1-6 - High Byte
11	Zone 1 Strobe Duration	Zone 1+4 Strobe Duration	Zone 1-3 Strobe Duration	Zone 1-6 Strobe Duration
12	Zone 1 Strobe Rate	Zone 1+4 Strobe Rate	Zone 1-3 Strobe Rate	Zone 1-6 Strobe Rate
13	Zone 2 Intensity	Zone 2+5 Intensity	Zone 4-6 Intensity	
14	Red_2	Red_2+5	Red_4-6	
15	Green_2	Green_2+5	Green_4-6	
16	Blue_2	Blue_2+5	Blue_4-6	
17	White_2	White_2+5	White_4-6	
18	Zone 2 Strobe Duration	Zone 2+5 Strobe Duration	Zone 4-6 Strobe Duration	
19	Zone 2 Strobe Rate	Zone 2+5 Strobe Rate	Zone 4-6 Strobe Rate	
20	Zone 3 Intensity	Zone 3+6 Intensity		
21	Red_3	Red_3+6		
22	Green_3	Green_3+6	*Note: zone pattern depends on control channel setting	
23	Blue_3	Blue_3+6		
24	White_3	White_3+6		
25	Zone 3 Strobe Duration	Zone 3+6 Strobe Duration		
26	Zone 3 Strobe Rate	Zone 3+6 Strobe Rate		
27	Zone 4 Intensity			
28	Red_4			
29	Green_4			
30	Blue_4			
31	White_4			
32	Zone 4 Strobe Duration			
33	Zone 4 Strobe Rate			
34	Zone 5 Intensity			
35	Red_5			
36	Green_5			
37	Blue_5			
38	White_5			
39	Zone 5 Strobe Duration			
40	Zone 5 Strobe Rate			
41	Zone 6 Intensity			
42	Red_6			
43	Green_6			
44	Blue_6			
45	White_6			
46	Zone 6 Strobe Duration			
47	Zone 6 Strobe Rate			

Note: Refer to previous DMX mapping information for Color Presets, Strobe, Duration, Intensity Timing, Color Timing, and Control channels. Also, refer to "[Mapping 16-Bit Mode](#)" on page 44 for more information.

11. 6-Channel Mode

Table 19 provides DMX channel mapping of the DMX512 control values when the SL NITRO 510C LED STROBE Luminaire is in 6-Channel DMX512 mode (as set by the luminaire’s menu system).

Table 19: DMX Channel Mapping (6-Channel Mode)

DMX Channel	Parameter	Range DMX	Range%	Default - recommended console default values	Description
1	Master Intensity	0 - 255	0 - 100%	0	8-bit control for the intensity of the LED settings - 0 to 255 (full)
2	Color Presets	0 - 255	0 - 100%	0	<p>Select presets, variable color filters or chases as follows:</p> <p>Channel OFF (disabled) DMX 0 - 4 Preset 0 (OFF) DMX 5 - 6 Preset 1 DMX 7 - 8 Preset 2 DMX 9 - 10 Preset 3 DMX 11 - 12 Preset 4 DMX 13 - 14 Preset 5 DMX 15 - 16 Preset 6 DMX 17 - 18 Preset 7 DMX 19 - 20 Preset 8 DMX 21 - 22 Preset 9 DMX 23 - 24 Preset 10 DMX 25 - 26 Preset 11 DMX 27 - 28 Preset 12 DMX 29 - 30 Preset 13 DMX 31 - 32 Preset 14 DMX 33 - 34 Preset 15 DMX 35 - 36 Preset 16 DMX 37 - 38 Preset 17 DMX 39 - 40 Preset 18 DMX 41 - 42 Preset 19 DMX 43 - 44 Preset 20 DMX 45 - 46 Preset 21 DMX 47 - 48 Preset 22 DMX 49 - 50 Preset 23 DMX 51 - 52 Preset 24 DMX 53 - 54 Preset 25 DMX 55 - 56 Preset 26 DMX 57 - 58 Preset 27 DMX 59 - 60 Preset 28 DMX 61 - 62 Preset 29 DMX 63 - 64 Preset 30 DMX 65 - 66 Preset 31 DMX 67 - 68 CF_0_Color OFF DMX 69 - 70 CF_1_White 10000K DMX 71 - 72 CF_2_White 8000K DMX 73 - 74 CF_3_White 6500K DMX 75 - 76 CF_4_White 5600K DMX 77 - 78 CF_5_White 5000K DMX 79 - 80 CF_6_White 4500K DMX 81 - 82 CF_7_White 4000K DMX 83 - 84 CF_8_White 3200K DMX 85 - 86 CF_9_White 3000K DMX 87 - 88 CF_10_White 2700K DMX 89 - 90 CF_11_Moroccan Pink DMX 91 - 92 CF_12_Pink DMX 93 - 94 CF_13_Flesh Pink DMX 95 - 96 CF_14_Bright Rose DMX 97 - 98 CF_15_Follies Pink DMX 99 - 100 CF_16_Fuchsia Pink DMX 101 - 102 CF_17_Surprise Pink DMX 103 - 104 CF_18_Congo Blue DMX 105 - 106 CF_19_Blue DMX 107 - 108 CF_20_Virgin Blue DMX 109 - 110 CF_21_Midnight Maya DMX 111 - 112 CF_22_Double C.T Blue DMX 113 - 114 CF_23_Slate Blue DMX 115 - 116 CF_24_Regal Blue DMX 117 - 118 CF_25_Full C.T Blue DMX 119 - 120 CF_26_Steel Blue DMX 121 - 122</p> <p>CONTINUED NEXT PAGE</p>

Table 19: DMX Channel Mapping (6-Channel Mode)

2	Color Presets	0 - 255	0 - 100%	0	<p>CONTINUED FROM PREVIOUS PAGE</p> <p>CF_27_Lighter Blue DMX 123 - 124 CF_28_Cyan DMX 125 - 126 CF_29_Marine Blue DMX 127 - 128 CF_30_Soft Green DMX 129 - 130 CF_31_Moss Green DMX 131 - 132 CF_32_Green DMX 133 - 134 CF_33_Fem Green DMX 135 - 136 CF_34_JAS Green DMX 137 - 138 CF_35_Pale Green DMX 139 - 140 CF_36_Spring Yellow DMX 141 - 142 CF_37_Yellow DMX 143 - 144 CF_38_Deep Amber DMX 145 - 146 CF_39_Chrome Orange DMX 147 - 148 CF_40_Orange DMX 149 - 150 CF_41_Magenta DMX 151 - 152 CF_42_Flame Red DMX 153 - 154 CF_43_Purple DMX 155 - 156 Rotate CW Fast -> Slow DMX 157 - 171 Rotate ACW Slow -> Fast DMX 172 - 186 Random Color Fast -> Slow DMX 187 - 201</p> <p>Chase1 DMX 202 - 204 Chase2 DMX 205 - 207 Chase3 DMX 208 - 210 Chase4 DMX 211 - 213 Chase5 DMX 214 - 216 Chase6 DMX 217 - 219 Chase7 DMX 220 - 222 Chase8 DMX 223 - 225 Chase9 DMX 226 - 228 Chase10 DMX 229 - 231 User Chase1 DMX 232 - 234 User Chase2 DMX 235 - 237 User Chase3 DMX 238 - 240 User Chase4 DMX 241 - 243 User Chase5 DMX 244 - 246 User Chase6 DMX 247 - 249 User Chase7 DMX 250 - 252 User Chase8 DMX 253 - 255</p>
3	Strobe Duration	0 - 255	0 - 100%	0	Controls strobe duration. Refer to "Strobe Duration DMX Timing Detail" on page 47.
4	Strobe Rate	0 - 255	0 - 100%	0	Controls strobe rate operation. Refer to "Strobe Rate DMX Timing Detail" on page 46.
5	Strobe Effects	0 - 255	0 - 100%	0	<p>Controls strobe operation as follows:</p> <p>No Effect = DMX 0 - 5 (default) Ramp Up = DMX 6 - 42 Ramp Down = DMX 43 - 85 Ramp up/down = DMX 86 - 128 Random = DMX 129 - 171 Top row only = DMX 172 - 173 Bottom row only = DMX 174 - 175 Left zone only = DMX 176 - 178 Center zone only = DMX 179 - 180 Right zone only = DMX 181 - 182 Checker pattern A = DMX 183 - 184 Checker pattern B = DMX 185 - 186 Random zones = DMX 187 - 214 Circle zone chase CW = DMX 215 - 235 Circle zone chase CCW = DMX 236 - 255</p>

Table 19: DMX Channel Mapping (6-Channel Mode)

6	Control Channel	0 - 255	0 - 100%	0	<p>Control channel operation. Set control channel value to desired action, hold value for at least 5 seconds, then turn to 0. Set control channel value to 0 without any scaling.</p> <p>Default Setting on Console = DMX 0-4 Dimming Curve_linear = DMX 30 - 34 Dimming Curve_Square = DMX 35- 39 Dimming Curve_S-Curve = DMX 40 - 44 Dimming Curve_PL-Curve = DMX 45 - 49 Calibration_OFF = DMX 70 - 74 Calibration_ON = DMX 75 - 79 Fan_Auto = DMX 80 - 84 Fan_Off = DMX 85 - 89</p> <p><i>The following is only available for "Zones Mapping" protocol. The following is instantly applied and DOES NOT require the 5 second hold.</i></p> <p>Combined zone control - (all zones follow zone 1 setting) = DMX 100 - 104</p> <p><i>The following is only available for "2 Zones Modes". The following is instantly applied and does not require the 5 second hold:</i> Linear Pattern = DMX 105 - 108* Checker Pattern = 109 - 112* *See Figure 20.</p> <p>Not Used = DMX 113 - 250 (<i>Reserved for future use</i>)</p>
---	-----------------	---------	----------	---	---

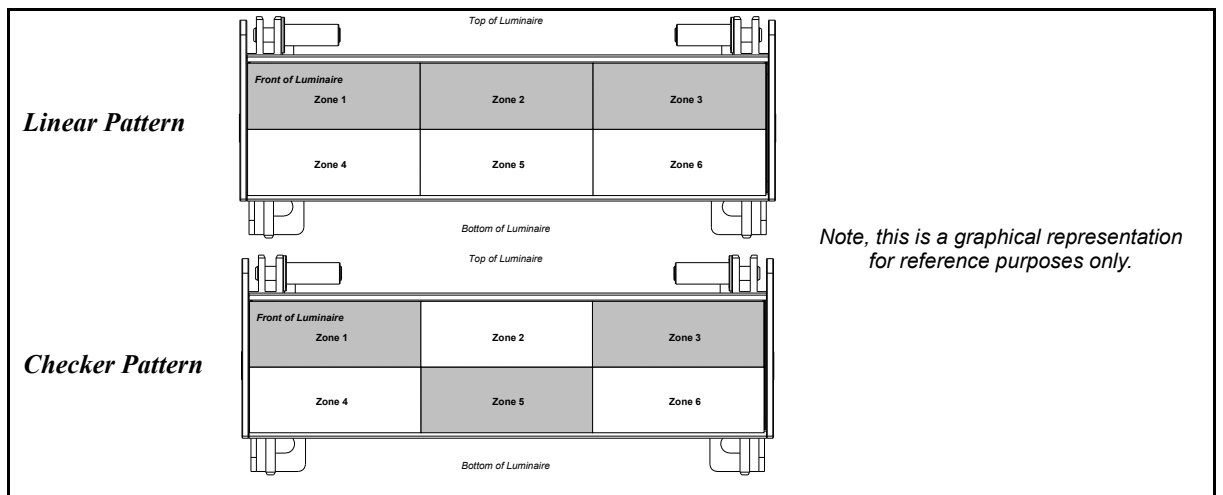

Figure 20: Linear & Checker Pattern

12. Mapping 16-Bit Mode

Table 20 provides DMX channel mapping of the DMX512 control values when the SL NITRO 510C LED STROBE Luminaire is in Mapping 16-Bit DMX512 mode (as set by the luminaire's menu system).

Note: When using pixel mapping software with the SL NITRO 510C LED STROBE Luminaire, it is suggested to only map the RGB channels and utilize the white channels independently. Refer to "RGB & W Operation" on page 24 for more information.

Table 20: DMX Channel Mapping (Mapping 16-Bit Mode)

DMX Channel	Parameter	Range DMX	Range%	Default - recommended console default values	Description
1	Red 1 - High	0 - 65535	0 - 100%	0	16-bit control of Red 1 LEDs from 0 to full
2	Red 1 - Low				
3	Green 1 - High	0 - 65535	0 - 100%	0	16-bit control of Green 1 LEDs from 0 to full
4	Green 1 - Low				
5	Blue 1 - High	0 - 65535	0 - 100%	0	16-bit control of Blue 1 LEDs from 0 to full
6	Blue 1 - Low				
7	White 1 - High	0 - 65535	0 - 100%	0	16-bit control of White 1 LEDs from 0 to full
8	White 1 - Low				
9	Red 2 - High	0 - 65535	0 - 100%	0	16-bit control of Red 2 LEDs from 0 to full
10	Red 2 - Low				
11	Green 2 - High	0 - 65535	0 - 100%	0	16-bit control of Green 2 LEDs from 0 to full
12	Green 2 - Low				
13	Blue 2 - High	0 - 65535	0 - 100%	0	16-bit control of Blue 2 LEDs from 0 to full
14	Blue 2 - Low				
15	White 2 - High	0 - 65535	0 - 100%	0	16-bit control of White 2 LEDs from 0 to full
16	White 2 - Low				
17	Red 3 - High	0 - 65535	0 - 100%	0	16-bit control of Red 3 LEDs from 0 to full
18	Red 3 - Low				
19	Green 3 - High	0 - 65535	0 - 100%	0	16-bit control of Green 3 LEDs from 0 to full
20	Green 3 - Low				
21	Blue 3 - High	0 - 65535	0 - 100%	0	16-bit control of Blue 3 LEDs from 0 to full
22	Blue 3 - Low				
23	White 3 - High	0 - 65535	0 - 100%	0	16-bit control of White 3 LEDs from 0 to full
24	White 3 - Low				
25	Red 4 - High	0 - 65535	0 - 100%	0	16-bit control of Red 4 LEDs from 0 to full
26	Red 4 - Low				
27	Green 4 - High	0 - 65535	0 - 100%	0	16-bit control of Green 4 LEDs from 0 to full
28	Green 4 - Low				
29	Blue 4 - High	0 - 65535	0 - 100%	0	16-bit control of Blue 4 LEDs from 0 to full
30	Blue 4 - Low				
31	White 4 - High	0 - 65535	0 - 100%	0	16-bit control of White 4 LEDs from 0 to full
32	White 4 - Low				
33	Red 5 - High	0 - 65535	0 - 100%	0	16-bit control of Red 5 LEDs from 0 to full
34	Red 5 - Low				
35	Green 5 - High	0 - 65535	0 - 100%	0	16-bit control of Green 5 LEDs from 0 to full
36	Green 5 - Low				
37	Blue 5 - High	0 - 65535	0 - 100%	0	16-bit control of Blue 5 LEDs from 0 to full
38	Blue 5 - Low				
39	White 5 - High	0 - 65535	0 - 100%	0	16-bit control of White 5 LEDs from 0 to full
40	White 5 - Low				

Table 20: DMX Channel Mapping (Mapping 16-Bit Mode)

41	Red 6 - High	0 - 65535	0 - 100%	0	16-bit control of Red 6 LEDs from 0 to full
42	Red 6 - Low				
43	Green 6 - High	0 - 65535	0 - 100%	0	16-bit control of Green 6 LEDs from 0 to full
44	Green 6 - Low				
45	Blue 6 - High	0 - 65535	0 - 100%	0	16-bit control of Blue 6 LEDs from 0 to full
46	Blue 6 - Low				
47	White 6 - High	0 - 65535	0 - 100%	0	16-bit control of White 6 LEDs from 0 to full
48	White 6 - Low				

13. SL NITRO 510C LED Groups/Zones

Table 12 on page 28, Table 14 on page 32, Table 16 on page 36, and Table 18 on page 40 provides DMX channel mapping of all DMX512 control values when the SL NITRO 510C LED STROBE Luminaire is set to multiple LED groups/zones (as set by the luminaire’s menu system). **Figure 21** indicates each Zone in relationship to the front of the luminaire.

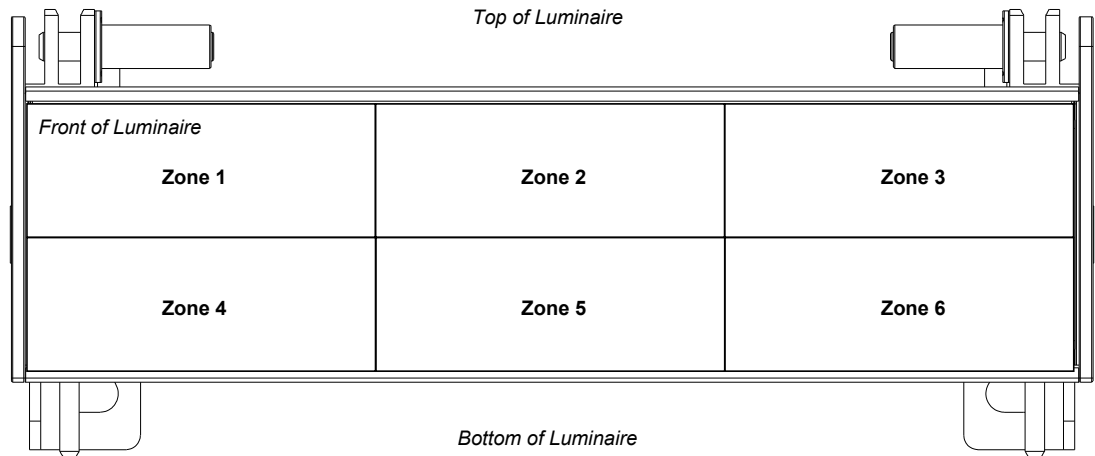

Note, this is a graphical representation for Zone identification purposes only.

Figure 21: SL NITRO 510C LED STROBE Luminaire Zones

Note: For DMX Channel Mapping, refer to Table 12, “DMX Channel Mapping (RGBW Full Group Modes),” on page 28, Table 14, “DMX Channel Mapping (RGBW Expanded Group Modes),” on page 32, Table 16, “DMX Channel Mapping (RGBW 16-Bit Group Modes),” on page 36, or Table 18, “DMX Channel Mapping (RGBW 8-Bit Group Modes),” on page 40.

14. Strobe Rate DMX Timing Detail

The chart below describes the Strobe Rate DMX parameters of the SL NITRO 510C LED STROBE Luminaire.

DMX Value	Percent (%)	Frequency (Hz)	DMX Value	Percent (%)	Frequency (Hz)	DMX Value	Percent (%)	Frequency (Hz)	DMX Value	Percent (%)	Frequency (Hz)	DMX Value	Percent (%)	Frequency (Hz)
0	0		60		0.635	120	47	0.910	168	66	1.386	228		4.065
1			61	24	0.635	121		0.910	169		1.418	229		4.065
2			62		0.642	122		0.924	170		1.418	230	90	4.355
3	1		63		0.642	123		0.924	171	67	1.452	231		4.355
4			64	25	0.649	124		0.938	172		1.452	232	91	4.690
5	2		65		0.649	125	49	0.938	173	68	1.452	233		4.690
6		0.500	66	26	0.656	126		0.953	174		1.487	234		5.081
7		0.500	67		0.656	127		0.953	175		1.487	235	92	5.081
8	3	0.504	68		0.663	128	50	0.968	176	69	1.524	236		5.543
9		0.504	69	27	0.663	129		0.968	177		1.524	237	93	5.543
10	4	0.508	70		0.670	130	51	0.983	178		1.563	238		6.098
11		0.508	71	28	0.670	131		0.983	179	70	1.563	239		6.098
12		0.512	72		0.678	132		1.000	180		1.605	240	94	6.775
13	5	0.512	73		0.678	133	52	1.000	181	71	1.605	241		6.775
14		0.517	74	29	0.685	134		1.016	182		1.648	242	95	7.622
15	6	0.517	75		0.685	135	53	1.016	183		1.648	243		7.622
16		0.521	76	30	0.693	136		1.033	184	72	1.694	244		8.711
17		0.521	77		0.693	137		1.033	185		1.694	245	96	8.711
18	7	0.526	78		0.701	138	54	1.051	186	73	1.742	246		10.163
19		0.526	79	31	0.701	139		1.051	187		1.742	247	97	10.163
20	8	0.530	80		0.709	140	55	1.070	188		1.793	248		12.195
21		0.530	81		0.709	141		1.070	189	74	1.793	249		12.195
22		0.535	82	32	0.717	142		1.089	190		1.848	250	98	15.244
23	9	0.535	83		0.717	143	56	1.089	191	75	1.848	251		15.244
24		0.540	84	33	0.726	144		1.089	192		1.905	252	99	20.325
25	10	0.540	85		0.726	145	57	1.109	193		1.905	253		20.325
26		0.544	86		0.735	146		1.109	194	76	1.967	254		30.488
27		0.544	87	34	0.735	147		1.129	195		1.967	255	100	30.488
28	11	0.549	88		0.735	148	58	1.129	196	77	2.033			
29		0.549	89	35	0.744	149		1.150	197		2.033			
30		0.554	90		0.744	150	59	1.150	198		2.103			
31	12	0.554	91		0.753	151		1.173	199	78	2.103			
32		0.554	92	36	0.753	152		1.173	200		2.103			
33	13	0.559	93		0.762	153	60	1.196	201	79	2.178			
34		0.559	94	37	0.762	154		1.196	202		2.178			
35		0.565	95		0.772	155		1.220	203		2.258			
36	14	0.565	96		0.772	156	61	1.220	204	80	2.258			
37		0.570	97	38	0.782	157		1.244	205		2.345			
38	15	0.570	98		0.782	158	62	1.244	206	81	2.345			
39		0.575	99	39	0.792	159		1.270	207		2.439			
40		0.575	100		0.792	160		1.270	208		2.439			
41	16	0.581	101		0.802	161	63	1.297	209	82	2.541			
42		0.581	102	40	0.802	162		1.297	210		2.541			
43	17	0.586	103		0.813	163	64	1.326	211		2.651			
44		0.586	104		0.813	164		1.326	212	83	2.651			
45		0.592	105	41	0.824	165		1.355	213		2.772			
46	18	0.592	106		0.824	166	65	1.355	214	84	2.772			
47		0.598	107	42	0.835	167		1.386	215		2.904			
48	19	0.598	108		0.835	168	66	1.386	216		2.904			
49		0.604	109		0.847	169		1.418	217	85	3.049			
50		0.604	110	43	0.847	170		1.418	218		3.049			
51	20	0.610	111		0.859	171	67	1.452	219	86	3.209			
52		0.610	112	44	0.859	172		1.452	220		3.209			
53		0.616	113		0.871	173	68	1.452	221		3.388			
54	21	0.616	114		0.871	174		1.487	222	87	3.388			
55		0.622	115	45	0.884	175		1.487	223		3.587			
56	22	0.622	116		0.884	176	69	1.524	224	88	3.587			
57		0.629	117	46	0.884	177		1.524	225		3.811			
58		0.629	118		0.897	178		1.563	226		3.811			
59	23	0.635	119		0.897	179	70	1.563	227	89	4.065			

NOTE: Continuous Mode (when strobe duration is also at 255)

Note: Continuous ON Mode illuminates all LEDs without strobing. This feature is activated when Strobe Rate and Strobe Duration are both set to DMX value 255.

15. Strobe Duration DMX Timing Detail

The chart below describes the Strobe Duration DMX parameters of the SL NITRO 510C LED STROBE Luminaire.

DMX Value	Percent (%)	Time (ms)	DMX Value	Percent (%)	Time (ms)	DMX Value	Percent (%)	Time (ms)	DMX Value	Percent (%)	Time (ms)	DMX Value	Percent (%)	Time (ms)
0	0	0	60		1968	120	47	3936	180		5904	240	94	7872
1		33	61	24	2001	121		3969	181	71	5937	241		7905
2		66	62		2034	122	48	4002	182		5970	242	95	7938
3	1	98	63		2066	123		4034	183		6002	243		7970
4		131	64	25	2099	124		4067	184	72	6035	244		8003
5	2	164	65		2132	125	49	4100	185		6068	245	96	8036
6		197	66	26	2165	126		4133	186	73	6101	246		8069
7		230	67		2198	127		4166	187		6134	247	97	8102
8	3	262	68		2230	128	50	4198	188		6166	248		8134
9		295	69	27	2263	129		4231	189	74	6199	249		8167
10	4	328	70		2296	130	51	4264	190		6232	250	98	8200
11		361	71	28	2329	131		4297	191	75	6265	251		8233
12		394	72		2362	132		4330	192		6298	252	99	8266
13	5	426	73		2394	133	52	4362	193		6330	253		8298
14		459	74	29	2427	134		4395	194	76	6363	254		8331
15	6	492	75		2460	135	53	4428	195		6396	255	100	8364
16		525	76	30	2493	136		4461	196	77	6429			
17		558	77		2526	137		4494	197		6462			
18	7	590	78		2558	138	54	4526	198		6494			
19		623	79	31	2591	139		4559	199	78	6527			
20	8	656	80		2624	140	55	4592	200		6560			
21		689	81		2657	141		4625	201	79	6593			
22		722	82	32	2690	142		4658	202		6626			
23	9	754	83		2722	143	56	4690	203		6658			
24		787	84	33	2755	144		4723	204	80	6691			
25	10	820	85		2788	145	57	4756	205		6724			
26		853	86		2821	146		4789	206	81	6757			
27		886	87	34	2854	147		4822	207		6790			
28	11	918	88		2886	148	58	4854	208		6822			
29		951	89	35	2919	149		4887	209	82	6855			
30		984	90		2952	150	59	4920	210		6888			
31	12	1017	91		2985	151		4953	211		6921			
32		1050	92	36	3018	152		4986	212	83	6954			
33	13	1082	93		3050	153	60	5018	213		6986			
34		1115	94	37	3083	154		5051	214	84	7019			
35		1148	95		3116	155		5084	215		7052			
36	14	1181	96		3149	156	61	5117	216		7085			
37		1214	97	38	3182	157		5150	217	85	7118			
38	15	1246	98		3214	158	62	5182	218		7150			
39		1279	99	39	3247	159		5215	219	86	7183			
40		1312	100		3280	160		5248	220		7216			
41	16	1345	101		3313	161	63	5281	221		7249			
42		1378	102	40	3346	162		5314	222	87	7282			
43	17	1410	103		3378	163	64	5346	223		7314			
44		1443	104		3411	164		5379	224	88	7347			
45		1476	105	41	3444	165		5412	225		7380			
46	18	1509	106		3477	166	65	5445	226		7413			
47		1542	107	42	3510	167		5478	227	89	7446			
48	19	1574	108		3542	168	66	5510	228		7478			
49		1607	109		3575	169		5543	229		7511			
50		1640	110	43	3608	170		5576	230	90	7544			
51	20	1673	111		3641	171	67	5609	231		7577			
52		1706	112	44	3674	172		5642	232	91	7610			
53		1738	113		3706	173	68	5674	233		7642			
54	21	1771	114		3739	174		5707	234		7675			
55		1804	115	45	3772	175		5740	235	92	7708			
56	22	1837	116		3805	176	69	5773	236		7741			
57		1870	117	46	3838	177		5806	237	93	7774			
58		1902	118		3870	178		5838	238		7806			
59	23	1935	119		3903	179	70	5871	239		7839			

NOTE: Cont nuous Mode (when strobe rate is also at 255)

Note: Continuous ON Mode illuminates all LEDs without strobing. This feature is activated when Strobe Rate and Strobe Duration are both set to DMX value 255.

16. SL NITRO 510C LED STROBE Luminaire RDM Parameter IDs

The following tables outline and describe all the RDM parameters IDs associated with SL NITRO 510C LED STROBE Luminaires.

- Table 21, “SL NITRO 510C LED STROBE Luminaire RDM Product Parameters IDs”
- Table 22, “SL NITRO 510C LED STROBE Luminaire RDM UID”
- Table 23, “SL NITRO 510C LED STROBE Luminaire RDM Parameters IDs”
- Table 24, “SL NITRO 510C LED STROBE Luminaire RDM Manufacturer Status IDs,” on page 50
- Table 25, “SL NITRO 510C LED STROBE Luminaire RDM Manufacturer Specific PIDs for Root Device,” on page 50
- Table 26, “SL NITRO 510C LED STROBE Luminaire RDM Manufacturer Specific PIDs for Sub Device,” on page 51

Table 21: SL NITRO 510C LED STROBE Luminaire RDM Product Parameters IDs

Model ID	Manufacturer	Model Description	Product Category
0x11C0	Entertain. Lighting Asia	SL NITRO 510C	0x0509

Table 22: SL NITRO 510C LED STROBE Luminaire RDM UID

UID					
MSB of ESTA 50H	LSB of ESTA 41H	1st of Unique Seq.	2nd of Unique Seq.	3rd of Unique Seq.	4th of Unique Seq.

Table 23: SL NITRO 510C LED STROBE Luminaire RDM Parameters IDs

Get Allowed	Set Allowed	RDM Parameter IDs	Value	Comment	Implemented
<i>Category - Network Management</i>					
		DISC_UNIQUE_BRANCH	0x0001		■
		DISC_MUTE	0x0002		■
		DISC_UN_MUTE	0x0003		■
■		PROXIED_DEVICES	0x0010		
■		PROXIED_DEVICES_COUNT	0x0011		
■	■	COMMS_STATUS	0x0015		
<i>Category - Status Collection</i>					
■		QUEUED_MESSAGE	0x0020		■
■		STATUS_MESSAGES	0x0030		■
■		STATUS_ID_DESCRIPTION	0x0031		■
	■	CLEAR_STATUS_ID	0x0032		■
■	■	SUB_DEVICE_STATUS_REPORT_THRESHOLD	0x0033		
<i>Category - RDM Information</i>					
■		SUPPORTED_PARAMETERS	0x0050	<i>Support required only if supporting Parameters beyond the minimum required set.</i>	■
■		PARAMETER_DESCRIPTION	0x0051	<i>Support required for Manufacturer-Specific PIDs exposed in SUPPORTED_PARAMETERS message.</i>	■
<i>Category - Product Information</i>					

Table 23: SL NITRO 510C LED STROBE Luminaire RDM Parameters IDs

Get Allowed	Set Allowed	RDM Parameter IDs	Value	Comment	Implemented
■		DEVICE_INFO	0x0060		■
■		PRODUCT_DETAIL_ID_LIST	0x0070		
■		DEVICE_MODEL_DESCRIPTION	0x0080		■
■		MANUFACTURER_LABEL	0x0081		■
■	■	DEVICE_LABEL	0x0082		■
■	■	FACTORY_DEFAULTS	0x0090		■
■		LANGUAGE_CAPABILITIES	0x00A0		
■	■	LANGUAGE	0x00B0		
■		SOFTWARE_VERSION_LABEL	0x00C0		■
■		BOOT_SOFTWARE_VERSION_ID	0x00C1		
■		BOOT_SOFTWARE_VERSION_LABEL	0x00C2		
Category - DMX512 Setup					
■	■	DMX_PERSONALITY	0x00E0		■
■		DMX_PERSONALITY_DESCRIPTION	0x00E1		■
■	■	DMX_START_ADDRESS	0x00F0	Required if device uses a DMX Slot	■
■		SLOT_INFO	0x0120		■
■		SLOT_DESCRIPTION	0x0121		■
■		DEFAULT_SLOT_VALUE	0x0122		
Category - Sensors 0x02xx					
■		SENSOR_DEFINITION	0x0200		■
■	■	SENSOR_VALUE	0x0201		■
	■	RECORD_SENSORS	0x0202		
Category - Dimmer Settings 0x03xx - FUTURE USE					
Category - Power / Lamp Settings 0x04xx					
■	■	DEVICE_HOURS	0x0400		
■	■	LAMP_HOURS	0x0401		
■	■	LAMP_STRIKES	0x0402		
■	■	LAMP_STATE	0x0403		
■	■	LAMP_ON_MODE	0x0404		
■	■	DEVICE_POWER_CYCLES	0x0405		
Category - Display Settings 0x05xx					
■	■	DISPLAY_INVERT	0x0500		■
■	■	DISPLAY_LEVEL	0x0501		
Category - Configuration 0x06xx					
■	■	PAN_INVERT	0x0600		
■	■	TILT_INVERT	0x0601		
■	■	PAN_TILT_SWAP	0x0602		
■	■	REAL_TIME_CLOCK	0x0603		
Category - Control 0x10xx					
■	■	IDENTIFY_DEVICE	0x1000		■
	■	RESET_DEVICE	0x1001		
■	■	POWER_STATE	0x1010		

Table 23: SL NITRO 510C LED STROBE Luminaire RDM Parameters IDs

Get Allowed	Set Allowed	RDM Parameter IDs	Value	Comment	Implemented
■	■	PERFORM_SELFTEST	0x1020		
■		SELF_TEST_DESCRIPTION	0x1021		
	■	CAPTURE_PRESET	0x1030		
■	■	PRESET_PLAYBACK	0x1031		

Table 24: SL NITRO 510C LED STROBE Luminaire RDM Manufacturer Status IDs

<p>Manufacturer Specific messages are in the range of 0x8000 - 0xFFDF. Each Manufacturer-specific Status ID shall have a unique meaning, which shall be consistent across all products having a given Manufacturer ID. See Table B-2, ANSI E1.20-2010.</p>				
Status ID Message	Value	Data Value 1	Data Value 2	Status ID Description
8100H		00H	00H	ALL OK

Table 25: SL NITRO 510C LED STROBE Luminaire RDM Manufacturer Specific PIDs for Root Device

Get Allowed	Set Allowed	RDM Parameter IDs	Type	Length	Unit	Prefix	Min	Max	Default	Description
<i>Manufacturer Defined PIDs range is 0x8000-0xffdf. See Table A-3, ANSI E1.20-2010</i>										
■	■	8A00H	U8	1	None	None	0	100	100	Dimmer
■	■	8AB2H	U8	1	None	None	1	18	1	Chase
■	■	8AB0H	U8	1	None	None	0	43	0	Color Filter
■	■	8AB1H	U8	1	None	None	0	31	0	Preset
■	■	8A97H	U8	1	None	None	0	1	0	Fan Auto / Off Setup
■	■	8A98H	U8	1	None	None	0	255	0	Effect
■	■	8AC0H	U8	1	None	None	0	255	255	Intensity Timing
■	■	8AC2H	U8	1	None	None	0	255	0	Color Timing
■	■	8A40H	U8	1	None	None	0	1	0	Link Mode
■	■	8A42H	U8	1	None	None	0	1	0	Incandescent Effect
■	■	8AA1H	U8	1	None	None	0	3	0	Dimming Curve
■	■	8A0CH	U8	1	None	None	0	3	0	DMX Fail Mode
■	■	8AA0H	U8	1	None	None	0	4	0	Backlight Off Time
■	■	8AA2H	U8	1	None	None	0	94	0	Power Up Setup
■	■	8A44H	U8	1	None	None	0	1	0	Calibration On/Off Setup
■	■	8A41H	U8	1	None	None	0	1	0	Lock Fixture

Table 26: SL NITRO 510C LED STROBE Luminaire RDM Manufacturer Specific PIDs for Sub Device

Get Allowed	Set Allowed	RDM Parameter IDs	Type	Length	Unit	Prefix	Min	Max	Default	Description
<i>Manufacturer Defined PIDs range is 0x8000-0xffdf. See Table A-3, ANSI E1.20-2010</i>										
■	■	8A92H	U8	1	None	None	0	255	0	Strobe
■	■	8A94H	U8	1	None	None	0	255	0	Duration
■	■	8A04H	U8	1	None	None	0	100	100	Dimmer RED
■	■	8A05H	U8	1	None	None	0	100	100	Dimmer GREEN
■	■	8A06H	U8	1	None	None	0	100	100	Dimmer BLUE
■	■	8A07H	U8	1	None	None	0	100	100	Dimmer WHITE

CLEANING AND CARE



WARNING! All cleaning should be performed with power completely removed from the luminaire. Never remove protective covers when luminaire is powered. Wear appropriate protective eye wear and gloves when cleaning the fixture. All service and maintenance, other than described herein, should be performed by a qualified technician or Authorized Service Center.

1. Special Cleaning and Care Instructions

Being a solid-state fixture, and unlike most fixtures, the SL NITRO 510C LED STROBE Luminaire requires very little routine maintenance by the user. This section covers portions of the luminaire that can be removed for cleaning. The SL NITRO 510C LED STROBE Luminaire special care when it comes to cleaning front lens assembly. Additional care needs to be taken with the plastic components because they are much easier to scratch or damage than glass.

The following is a list of cleaning materials required to care for your SL NITRO 510C LED STROBE Luminaire:

- Lint free lens tissue
 - Lint or powder free gloves
 - Reagent grade isopropyl alcohol*
 - A mild soap solution.
-

Note: *Reagent grade isopropyl alcohol is good to use on the SL NITRO 510C LED STROBE Luminaire plastic optics with anti-reflection coatings.

If the lens is still dirty after using isopropyl alcohol, for instance if fingerprints or oil is just redistributed and not cleaned off the optic, then a mild soap and water solution can be used to gently wash the lens. Repeat the cleaning with isopropyl alcohol to eliminate streaks and soap residue.



WARNING! Under no circumstances should ammonia-based cleaners, acetone, or other harsh solvents be used on or near the SL NITRO 510C LED STROBE Luminaire. These types of cleaners or solvents can permanently damage the optics or housings of the fixture.

If you have any questions regarding the use or care of your SL NITRO 510C LED STROBE Luminaire, please contact Showline technical support or your local Authorized Dealer.

2. Front Lens Cleaning

To clean the front lens:

- Step 1. Disconnect luminaire from power and allow to cool completely.
- Step 2. Apply a small amount of reagent grade isopropyl alcohol to lint-free lens tissue.
- Step 3. Wipe all debris, dirt, fingerprints, etc. from lens.
- Step 4. Using a second lint-free lens tissue, wipe off any alcohol residue.

3. Service and Maintenance

For all other service and maintenance issues, please contact your local Showline office or an Authorized Service Center.



WARNING! Disassembly (other than as described herein), alterations, unauthorized service, etc. will void the product warranty. Contact your local Showline office or an Authorized Service Center for technical support and service.

TECHNICAL SPECIFICATIONS

1. SL NITRO 510C LED STROBE Luminaire Operational Specifications

Source:	High Intensity RGB & W LED Array (x264 Red, Green, Blue / x 264 White)
Beam Angle:	120 Degrees
Light Output:	> 50,000 lumens
Strobe Operation:	Variable Strobe: 0 to 650 ms / Strobe Rate: 0 to 30 flashes per second
Color Temperature:	6500K
Input Voltage (AC):	100V to 240V (+/- 10%, auto-ranging)
Current (AC):	3.6 Amps (100V) / 1.50 Amps (240V)
Frequency:	50/60Hz
Control Protocols:	DMX512 (1990) / DMX512A (RDM) / On-Board Menu
Ambient Temperature:	-20 to 40 Degrees C (-4 to 104 Degrees F)
Humidity:	5%-95% Non condensing
Cooling:	Forced Air Cooling
Weight:	17.6 lbs (8 kg) - Luminaire only (no accessories)
Housing:	Die Cast Aluminium with Powder Coating
Compliance:	cETLus marked (North American models) / CE Marked (International models) / cTick
IP Rating:	IP20

2. SL NITRO 510C LED STROBE Luminaire Dimensions

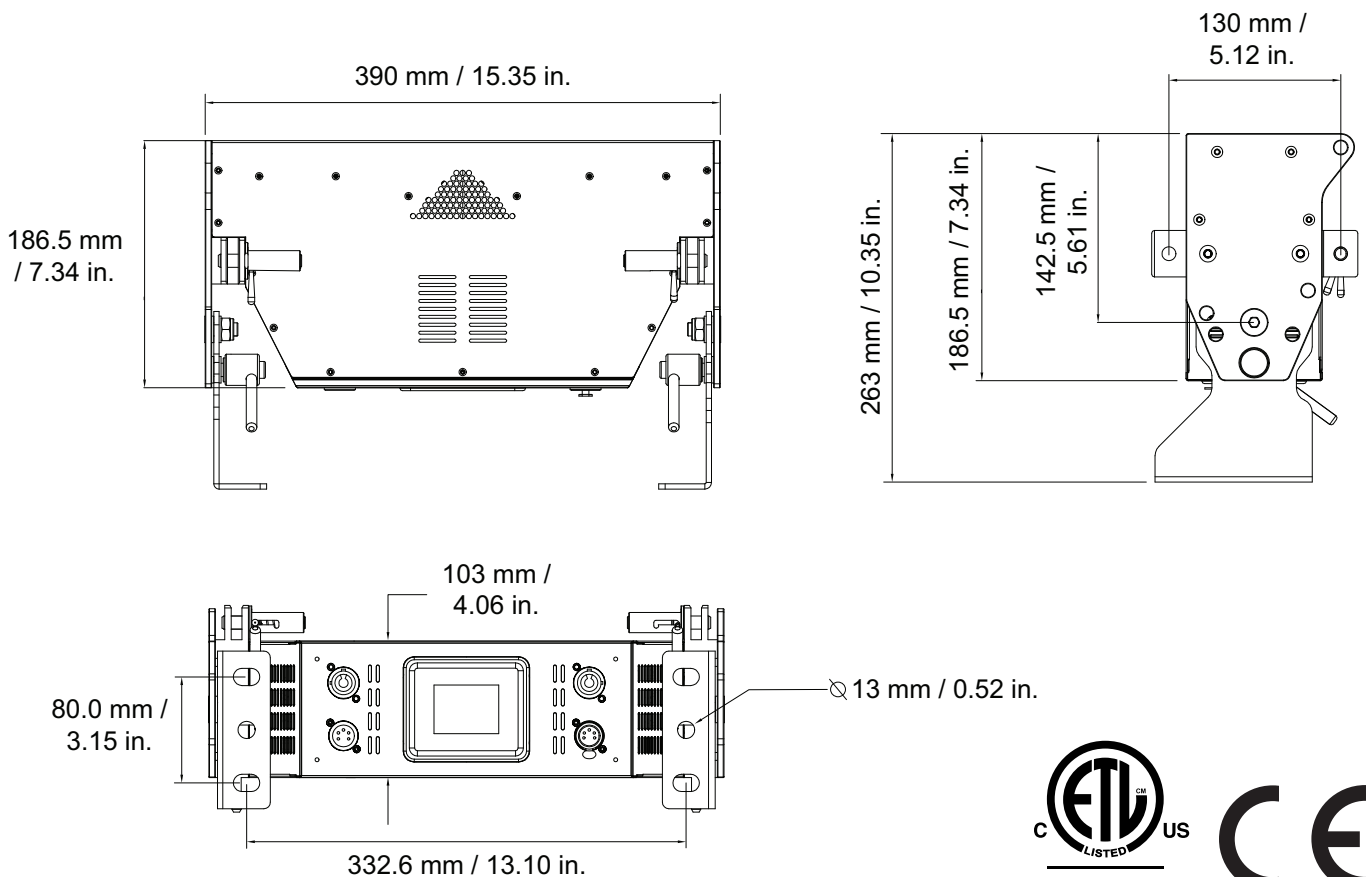

TECHNICAL SUPPORT

GLOBAL 24HR TECHNICAL SUPPORT:

Call: +1 214 647 7880
entertainment.service@signify.com

NORTH AMERICA SUPPORT:

Call: 877-VARI-LITE (877-827-4583)
entertainment.service@signify.com

EUROPEAN CUSTOMER SERVICE CENTER:

Call: +31 (0) 543 542 531
entertainment.europe@signify.com

©2022 Signify Holding. All rights reserved.

All trademarks are owned by Signify Holding or their respective owners. The information provided herein is subject to change, without notice. Signify does not give any representation or warranty as to the accuracy or completeness of the information included herein and shall not be liable for any action in reliance thereon. The information presented in this document is not intended as any commercial offer and does not form part of any quotation or contract, unless otherwise agreed by Signify. Data subject to change.

vls_copyright