

Automatic Release Options

Electro Thermal Link

- Used to connect the fire curtain system to fire alarms or other electrical systems
- Link separates when electricity is applied
- UL Listed



**Electro Thermal Link
016-ETL**

Resettable Electro Thermal Link

- Allows fire detection systems such as rate of rise detectors or other electrical signals to release the fire curtain
- Works with sensors using either "Normally Open" or "Normally Closed" contacts
- When triggered, the mechanism releases tension in the fire line, allowing the fire safety curtain to close
- The release mechanism may be attached to the end of the fire line and does not interfere with other release mechanisms
- Requires 24V AC/DC (2.3 amps) to operate and release from building fire alarm system
- UL Listed

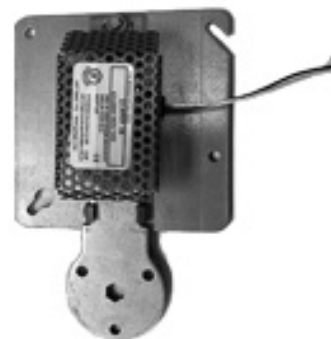

**Resettable Electro Thermal Link
016-2841**

Rate of Rise Detector

- Used to release fire curtain when:
 - Temperature raises 15°F (7.1°C) in one minute
 - Temperature exceeds 135°F (57.2°C)
- Normally open contact
- UL Listed



**Rate of Rise Detector
099-5601P**

Fusible Link

- Placed in the fire line to release the fire curtain
- Link separates at a temperature of 165°F (74°C)
- UL Listed

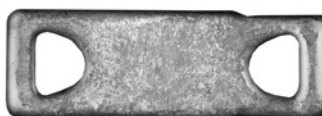

**Fusible Link
016-7519**

Order Information

Number	Description
016-ETL	Electro Thermal Link
016-2841	Resettable Electro Thermal Link
099-5601P	Rate of Rise Detector
016-7519	Fusible Link

Dimensions

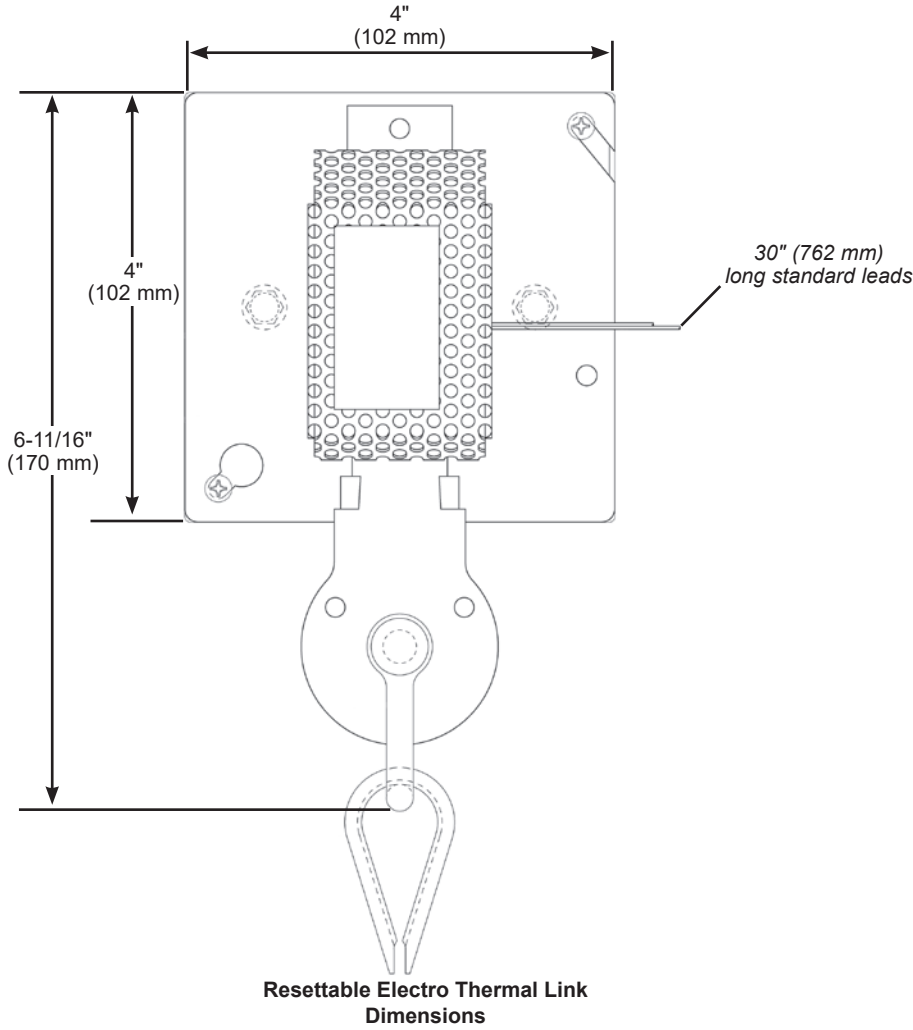
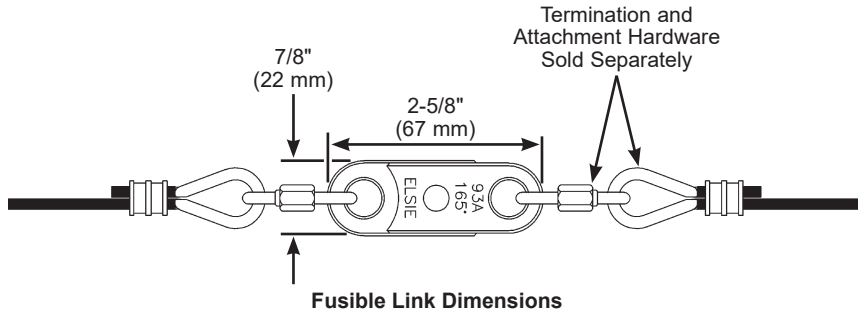

Music Education and Performing Arts

Owatonna Office: Phone 800.4WENGER (493-6437) Worldwide +1.507.455.4100 | Parts & Service 800.887.7145 | wengercorp.com
555 Park Drive, PO Box 448 | Owatonna | MN 55060-0448

Syracuse Office: Phone 800.836.1885 Worldwide +1.315.451.3440 | jrclancy.com | 7041 Interstate Island Road | Syracuse | NY 13209-9713

Athletics Phone 800.493.6437 | email gearboss@wengercorp.com | gearboss.com | 555 Park Drive, PO Box 448 | Owatonna | MN 55060-0448