

# EuroLock

- Single handed operation
- Positive locking mechanism with button release
- Sliding cam locking device reduces wear on hand line
- Adjustable tensioning to accommodate 3/4"-1" diameter ropes
- Mounts on standard JR Clancy locking rails
- Pad-lock compatible for safe lock-out

**Please Note:**

Rope locks are not designed to hold an imbalance of more than 50 lb (22.6 kg), nor to be used as a speed control.

## Dimensions

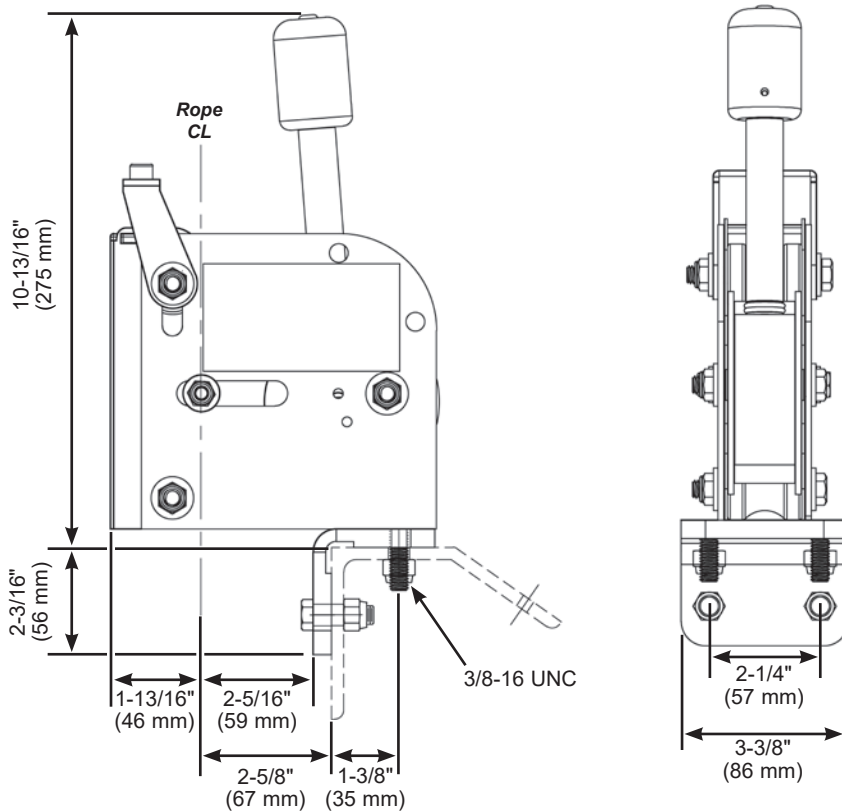

## Order Information

Number	Description	RWL	Weight
010-2852	EuroLock	50 lb (22.6 kg)	12 lb (5.4 kg)
010-PLOCK	Padlock for Rope Lock	—	1 lb (0.45 kg)

**RWL:** RWL is maximum load that can be applied to the rope lock which is in "like new" condition and has been properly installed, maintained, and operated.



© 2022 Wenger Corporation  
USA/2022-10

### MUSIC EDUCATION AND PERFORMING ARTS

Owatonna Office: Phone 800.4WENGER (493-6437) Worldwide +1.507.455.4100 | Parts & Service 800.887.7145 | wengercorp.com  
555 Park Drive, PO Box 448 | Owatonna | MN 55060-0448

Syracuse Office: Phone 800.836.1885 Worldwide +1.315.451.3440 | jrclancy.com | 7041 Interstate Island Road | Syracuse | NY 13209-9713

**ATHLETICS** Phone 800.493.6437 | email gearboss@wengercorp.com | gearboss.com | 555 Park Drive, PO Box 448 | Owatonna | MN 55060-0448