

Light Duty Blocks

- For use in light duty applications such as supporting fire lines
- 3" (76 mm) diameter steel sheaves
- Formed steel base allows vertical or horizontal mounting
- Available with 3/8" (9.5 mm) or 1/8" (3.175 mm) groove



**Light Duty Block
013-175**

Dimensions

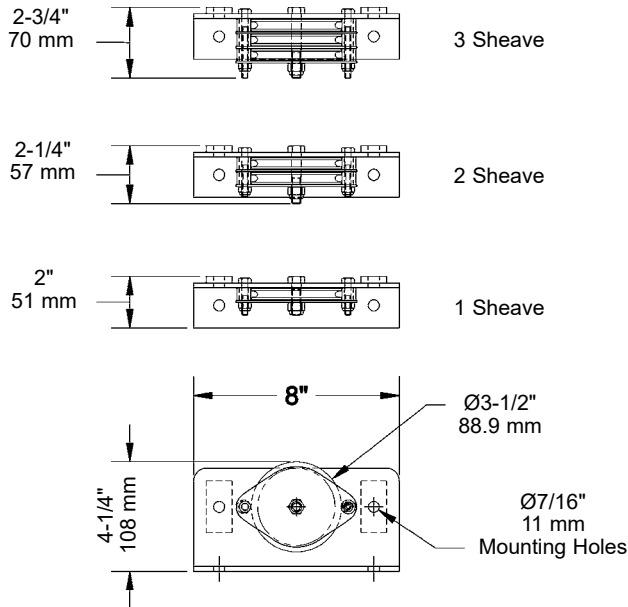

Order Information

Number	Description	RWL	Weight
Grooved for 3/8" (9.5 mm) Rope			
013-175	3" (76 mm, 1 Sheave for 3/8" (9.5 mm) Rope	50 lb (27.6 kg)	3.5 lb (1.6 kg)
013-275	3" (76 mm, 2 Sheave for 3/8" (9.5 mm) Rope	100 lb (45.3 kg)	3.5 lb (1.6 kg)
013-375	3" (76 mm, 3 Sheave for 3/8" (9.5 mm) Rope	150 lb (68 kg)	3.5 lb (1.6 kg)
Grooved for 1/8" (3.175 mm) Rope			
013-176	3" (76 mm, 1 Sheave for 1/8" (3 mm) Rope	50 lb (27.6 kg)	3.5 lb (1.6 kg)
013-276	3" (76 mm, 2 Sheave for 1/8" (3 mm) Rope	100 lb (45.3 kg)	3.5 lb (1.6 kg)
013-376	3" (76 mm, 3 Sheave for 1/8" (3 mm) Rope	150 lb (68 kg)	3.5 lb (1.6 kg)
RWL: RWL is maximum load that can be applied to a block which is in "like new" condition and has been properly installed, maintained, and operated.			

MUSIC EDUCATION AND PERFORMING ARTS

Owatonna Office: Phone 800.4WENGER (493-6437) Worldwide +1.507.455.4100 | Parts & Service 800.887.7145 | wengercorp.com
555 Park Drive, PO Box 448 | Owatonna | MN 55060-0448

Syracuse Office: Phone 800.836.1885 Worldwide +1.315.451.3440 | jrclancy.com | 7041 Interstate Island Road | Syracuse | NY 13209-9713

ATHLETICS Phone 800.493.6437 | email gearboss@wengercorp.com | gearboss.com | 555 Park Drive, PO Box 448 | Owatonna | MN 55060-0448