

Rope Locks

- One piece ASTM A536 ductile iron body
- 10" (254 mm) handle, powder-coated ductile iron, contoured for comfort and ease of use
- Two iron cams grip rope with socket head adjustment screw for 5/8"-1" (15.875-25.4 mm) rope. Adjustment screw has a nylon tip for quiet operation.
- Integral ears for optional padlock
- Vinyl coated steel oval locking ring
- Rubber pad to quiet handle when it is opened

Please note:

Rope locks are not designed to hold an imbalance of more than 50 lb (22.6 kg), nor to be used as a speed control.



Rope Lock
010-533R

Dimensions

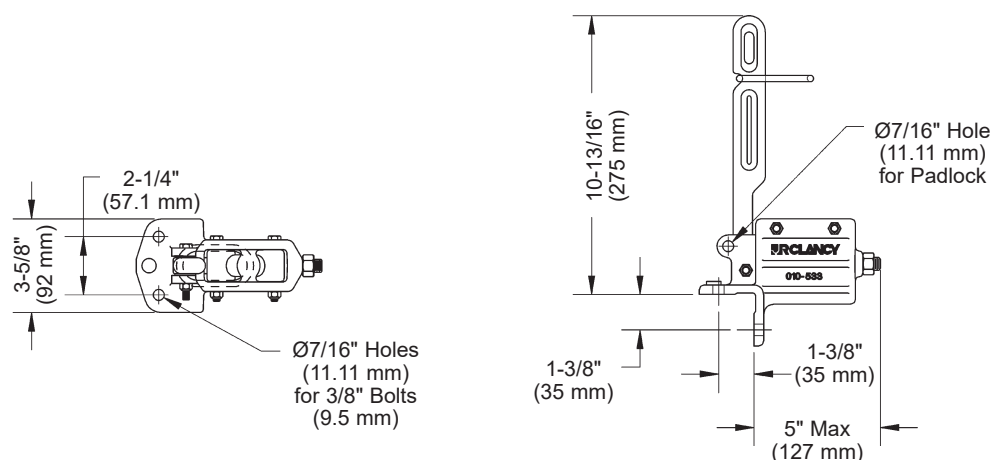

Order Information

Number	Description	RWL	Weight
010-533R	Rope Lock	50 lb (22.6 kg)	8 lb (3.6 kg)
010-PLOCK	Padlock for Rope Lock	—	1 lb (0.45 kg)
110-533C	Replacement Oval Ring, Vinyl Coated	—	0.1 lb (0.04 kg)

RWL: RWL is maximum load that can be applied to the rope lock which is in "like new" condition and has been properly installed, maintained, and operated.

MUSIC EDUCATION AND PERFORMING ARTS

Owatonna Office: Phone 800.4WENGER (493-6437) Worldwide +1.507.455.4100 | Parts & Service 800.887.7145 | wengercorp.com
555 Park Drive, PO Box 448 | Owatonna | MN 55060-0448

Syracuse Office: Phone 800.836.1885 Worldwide +1.315.451.3440 | jrclancy.com | 7041 Interstate Island Road | Syracuse | NY 13209-9713

ATHLETICS Phone 800.493.6437 | email gearboss@wengercorp.com | gearboss.com | 555 Park Drive, PO Box 448 | Owatonna | MN 55060-0448