

Motorized Fire Curtain Hoist

- Manufactured to Federal Specification RRC-271-E
- Motorized fire curtain hoist with integral speed regulation used to raise and lower fire curtains - up to 1,100 lb (499 kg)

Note: Hoist is designed for constant load between 500 lb (227 kg) and 1,100 lb (499 kg).
Brail curtains may require additional pipe weight to operate properly.

- Weight: 550 lb (249 kg)
- Max travel: Up to 30' (9144 mm)
- Available as wall mount or floor mount
- Push button control stations for easy operation
- Emergency lowering speed controlled by hydraulic speed regulator
- 50' (15.24 m) of 5/16" (7.9 mm) of drive line included
- Meets requirements of ANSI E1.22 – 2016 "Entertainment Technology Fire Safety Curtain Systems" or NFPA 80 "Standard for Fire Doors and Other Opening Protectives – 2016"
- Control Station included
- Available for operation on 208, 380 or 480 VAC 3 phase power, please confirm voltage at time of ordering

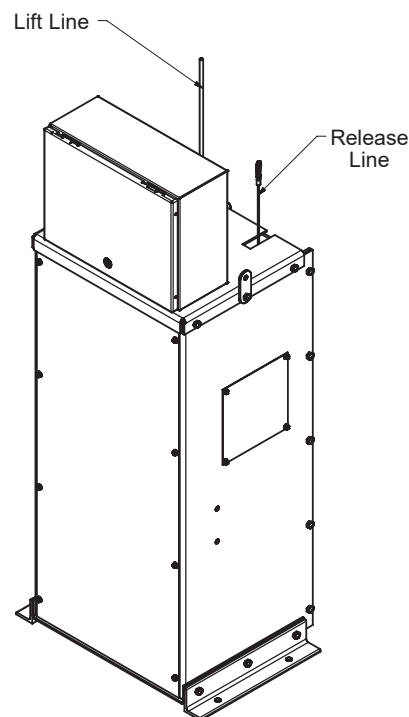

Motorized Fire Curtain Hoist

Dimensions

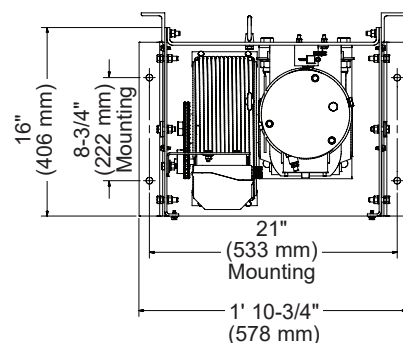
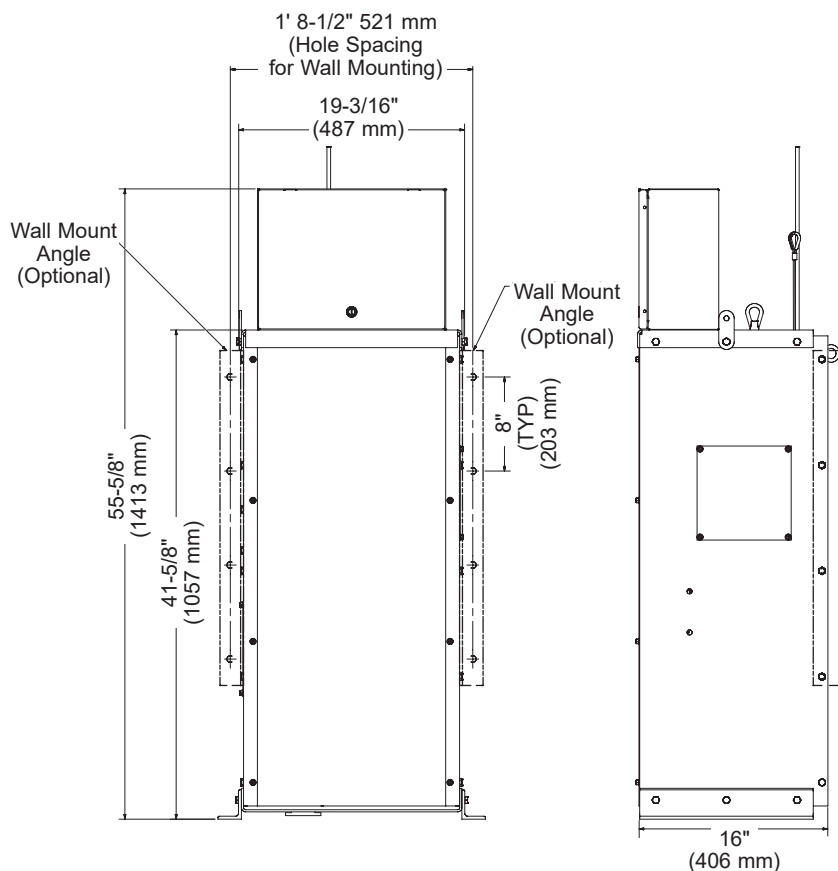

Music Education and Performing Arts

Owatonna Office: Phone 800.4WENGER (493-6437) Worldwide +1.507.455.4100 | Parts & Service 800.887.7145 | wengercorp.com
555 Park Drive, PO Box 448 | Owatonna | MN 55060-0448

Syracuse Office: Phone 800.836.1885 Worldwide +1.315.451.3440 | jrclancy.com | 7041 Interstate Island Road | Syracuse | NY 13209-9713

Athletics Phone 800.493.6437 | email gearboss@wengercorp.com | gearboss.com | 555 Park Drive, PO Box 448 | Owatonna | MN 55060-0448