



Features

- U. L. Listed
- Removable wireway covers
- High visibility circuit numbers
- Pre-wired for quick installation
- Flush mounted or pigtail connectors
- Rugged 16-gauge steel construction
- Custom built to customer specifications
- May be installed horizontally or vertically

Connector Strips



Description

EDI connector strips feature 16-gauge steel wireways with removable 6-ft. covers. The black finish aids concealment above the stage, while the two-inch pressure-sensitive white vinyl letters are easily readable.

All strips, including connector type, location, capacity, connector spacing, hanger brackets, labeling, and overall length, are built to customer specifications.

Hanger brackets for one, two, or three pipes are available, as

are ceiling/wall mounting brackets.

Connectors can be either flush mounted, or specified-length 12/3 SO pigtails. The connector strip is internally wired from the connector to a labeled terminal strip inside the terminal box (see Gridiron Box data sheet for multi-conductor cable and hardware details).

Terminal box connection to a flexible cable can be at center or either end.

Ordering Information

All connector strips are described by assigning the project-specific information to the position in the order number.

Example: CS 24 / 9 - 9 / 20GSP / P18 / 5S / BL
 1 2 3 4 5 6 7

Connector Types

(1) PBG	(2) GTL	(3) GSP
Parallel Blade Ground	Grounded Twist Lock	Grounded Stage Pin

Connector Strip / - / / / /
 1 2 3 4 5 6 7

Connector Strip

- 1. (length, ft.)
- 2. (# circuits)
- 3. (# connectors)

4. Connector Type

- (1) PBG: 5-20R 20A
- (2) GTL: L5-20R 20A
- (3) GSP: 20A
- 60A
- 100A
- (4) SP

5. Conn. Style

- Flush
- Pigtail
- Length:

6. Mounting Brackets

- S.. Single Pipe
- D.. Double Pipe
- T.. Triple Pipe
- W.. Ceiling or Wall
- C.. Custom

7. Terminal Box

- BL
- BR
- BC

JOB NUMBER:

APPROVAL STAMP

JOB NAME:

CUSTOMER:

P. O. #

Mounting Brackets

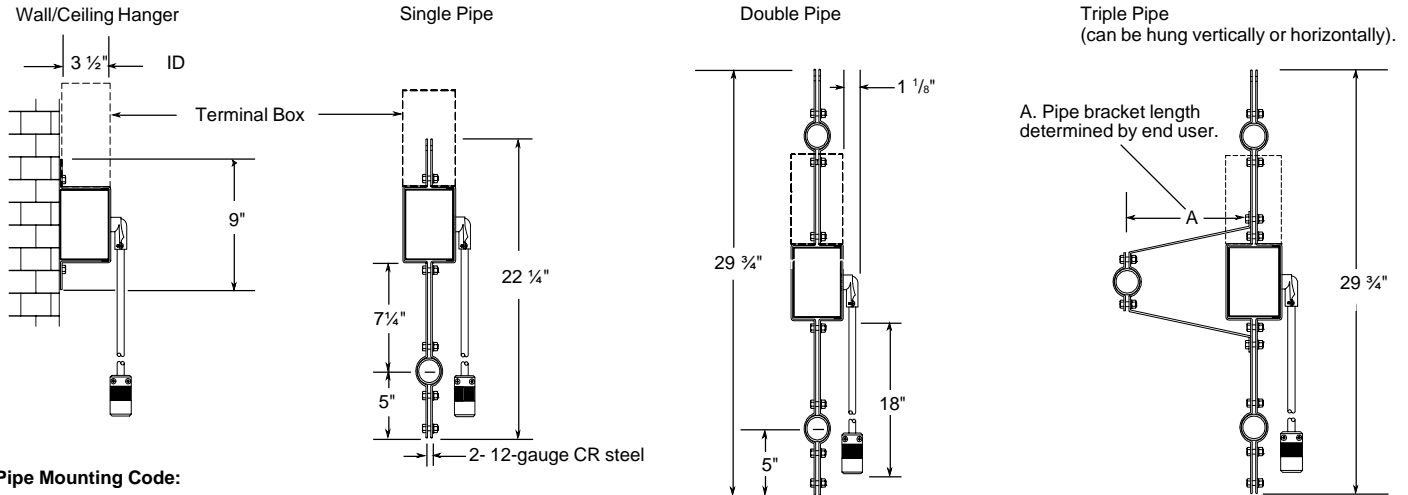

Pipe Mounting Code:

Single Pipe.. S Ceiling/Wall.. W
 Double Pipe.. D Custom..... C
 Triple Pipe.. T

Standard Connector Strip Includes:

1. Hanging brackets as specified, with hardware, for mounting every five feet.
2. Eyelet position on top of each pipe bracket for cable suspension.
3. Pressure sensitive white vinyl numbers or lettering, or as specified.
4. Numbers and circuits on the upstage side of *onstage* connector strips.
5. Numbers on both sides of *catwalk/FOH* connector strips.
6. Eighteen-inch pigtailed standard.

Shipping Weight: Approximately 12 lbs. (5.44kg) per foot. Connector strips are boxed and banded for ease of transportation.

Terminal Box

Over stage area, circuit numbers are viewed from upstage. Order **BL** or **BR**.

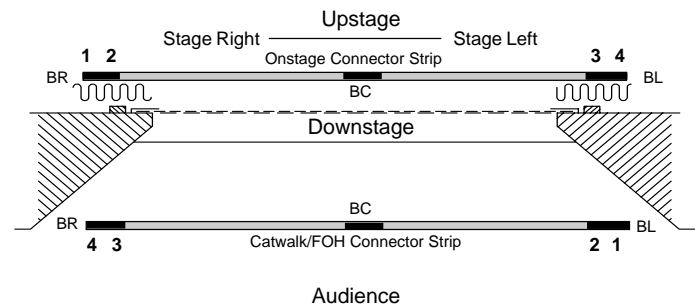

Specifications

1. This unit shall consist of a 3 1/2" x 4 3/4" 16-gauge cold-rolled steel wireway with removable cover sections for access, labeled with circuit numbers.
2. Each strip shall have a terminal compartment which shall be factory labeled and installed on the right, left, or center, as required.
3. Internal wiring shall be rated at 125° C, U.L. listed, sized according to load.
4. The connector strip shall be provided with 2-12-gauge cold-rolled steel brackets for mounting on 5' centers, to fit up to 2" pipe. 1.5" I.D. (2" O.D.) Schedule 40 black pipe to be supplied by others.
5. Type 12/3 SO cable pigtailed shall be furnished with three-pole, grounded female receptacles. Flush receptacles are available in lieu of pigtailed.
6. Circuit capacity shall be 20, 50, 60 or 100 Amp, per drawings, or as scheduled.
7. Circuits shall be marked with 2" permanent, pressure-sensitive white vinyl labels.
8. Exterior finish shall be baked black polyurethane enamel paint, and the entire unit shall be U.L. listed.
9. The connector strip shall be as manufactured by Electronics Diversified, Inc., Hillsboro, Oregon, U.S.A.

Specifications subject to change without notice. Specification applicable to standard products only.
 ©1998 Electronics Diversified, Inc. All rights reserved. Printed in USA.
 D101 0898