



Architectural Dimmers

Features

- Space-saving design
- Economical load control for a small number of dimmers
- Convection cooled, requires no fans
- Dims standard and low-voltage incandescent, quartz, fluorescent, neon and cold-cathode sources
- Class II low-voltage control circuitry in Analog 0 -10V
- Single 20 amp or Dual 10 amp capacity per module
- 120V, 240V and 277V models available
- Optional slider controls
- Overtemp protected
- U.L. listed

Versa-Pak Analog Dimmer



Description

The Versa-Pak wall-mount dimmer is designed for smaller lighting applications. The compact, self-contained enclosure utilizes a single module to dim incandescent, quartz, low-voltage, fluorescent, neon and cold-cathode sources.

Although designed for architectural dimming, the Versa-Pak wall-mount dimmer is engineered with the same quality

standards demanded in performance industry dimming systems.

Each module includes a backbox, heatsink, temperature sensor to monitor operating temperature, a reliable 40 Amp SSR package, toroidal filter and control electronics.

Order Information:

Incandescent Modules:

- VP-2/I-120 VP-D1/I-120
- VP-2/I-240 VP-D1/I-240
- VP-2/I-277

Neon/Cold-Cathode:

- VP-2/NC-120
- VP-2/NC-240
- VP-2/NC-277

Non-Dim Modules:

- VP-ND
- VP-ND-240
- VP-ND-277

Fluorescent, Mark VII

- Mark VII CICB
- VP-2/ADV-120
- VP-2/ADV-277

Control Option:

- Slider on Dimmer
- Sliders Remote

JOB NUMBER:

APPROVAL STAMP

JOB NAME:

CUSTOMER:

P. O. #

Electronics Diversified, Inc.

PRODUCT DATA SHEET

1675 N.W. Cornelius Pass Road ● Hillsboro, Oregon 97124 U.S.A.
 Phone: (503) 645-5533 ● FAX: (503) 629-9877 ● Web Site: www.edionline.com

A130

Electrical Characteristics

Input Power: Single phase, 120/240 VAC, 50/60 Hz. 20 Amp.
Circuit Breaker: by others,

Control Voltage: 0 - +10VDC

Operating Environment: Temperature range: 32° F. (0° C) to 104° F. (40° C).
Humidity range: 0% - 90% non-condensing.

Physical Characteristics

Dimensions: 9½" H x 6" W x 4" D
(24.13cm x 15.24cm x 10.16cm)

Shipping Weight: 9 lbs (4.08kg)

Dimming Module Description

All Versa-Pak modules are U.L. listed and labeled for load operation.

Incandescent

Model Number	Description
VP-2/I-120	Single 20 Amp (2400W) 120VAC dimmer
VP-2/I-240	Single 20 Amp (4800W) 240VAC dimmer
VP-2/I-277	Single 20 Amp 277VAC dimmer
VP-D1/I-120	Dual 10 Amp (1200W) 120VAC dimmer
VP-D1/I-240	Dual 10 Amp (2400W) 240VAC dimmer

Neon/Cold-Cathode

Model Number	Description
VP-2/NC-120	Single 20 Amp 120VAC neon or cold-cathode dimmer
VP-2/NC-240	Single 20 Amp 240VAC neon or cold-cathode dimmer
VP 2/NC-277	Single 20 Amp 277VAC neon or cold-cathode dimmer

System Riser

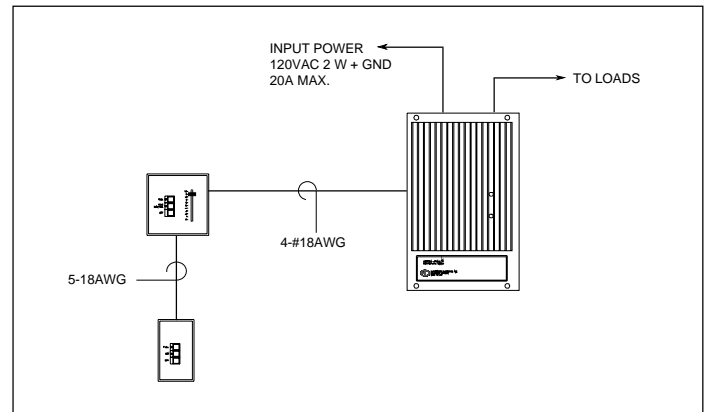

Non-Dim Modules

Model Number	Description
VP-ND-120	Single 20 Amp 120VAC non-dim
VP-ND-240	Single 20 Amp 240VAC non-dim
VP-ND-277	Single 20 Amp 277VAC non-dim

Fluorescent Ballast

Model Number	Description
Mark VII CICB	Consult factory for specific ballast information.
VP-2/ADV-120	Single 20 Amp 120VAC fluorescent dimmer
VP-2/ADV-277	Single 20 Amp 277VAC fluorescent dimmer

Specifications

- The enclosure shall surface mount.
- The enclosure shall accommodate single 20 Amp and/or Dual 10 Amp dimmers.
- The dimmers shall dim standard and low voltage incandescent, quartz, standard and/or dimming ballast fluorescent, and neon, or cold-cathode.
- The dimming system shall be convection cooled. The module shall include a thermal sensor to shut down the dimmer if the heatsink temperature exceeds 185° F. (85° C).
- The dimmers shall use an encapsulated pair of silicon controlled rectifiers to provide symmetrical alternating current output to the load at any output level from OFF to FULL intensity. The entire load of the dimmer shall be carried solely by the silicon-controlled rectifiers. The silicon-controlled rectifier shall inherently be designed in such a manner so that it is impossible for any spurious voltage to be transferred to the control wires and damage low voltage electronics. In addition to the optical isolation provided internally in the power cube device, the protection design shall employ a combination of Metal Oxide Varistors (MOV's), pico fuses and/or transzorb to provide complete protection. Dimmer modules without an individual thermal sensor shall not be acceptable.
- Each module shall have a toroidal, copper-wound, iron-core high performance choke. Performance rise time shall be no less than 325 µS. All measurements are from 10% to 90% at full load.
- Filters shall not be required for fluorescent or neon/cold-cathode models.
- The maximum heat loss for each 2.4Kw dimmer shall be no greater than 59 watts per dimmer or 100 BTU's per hour per connected Kw of load.
- The dimmer shall respond to a 0 - +10VDC signal. All control inputs shall be electrically isolated from the incoming line and control electronics.
- The dimmers shall operate over an input voltage range of 90 to 140 VAC. Nominal input voltage shall be 120 VAC. (120 VAC dimmers only).
- Incandescent dimmers shall function properly with any load from 25 watts to rated capacity.
- All control electronics shall be incorporated on a single double-sided FR4-G10, U.L. Listed, printed circuit board.
- The dimmer enclosure and modules shall be U.L. Listed.
- The dimmer system shall be the Versa-Pak series as manufactured by Electronics Diversified, Inc., Hillsboro, Oregon 97124, USA.

Specifications subject to change without notice. Specification applicable to standard products only.
©1998 Electronics Diversified, Inc. All rights reserved. Printed in U.S.A.
A130 0898