



VARI\***LITE**

VL3200 LT PROFILE IP

**USER MANUAL**

# INTRODUCTION

## OUR GOAL

---

We are committed to providing you the highest quality in customer service. Our comprehensive resources are available to help your business succeed and ensure you get the full benefit of being a Vari-Lite customer.

## TECHNICAL SUPPORT

Our Service and Support team is tasked with online and field support, repair, demo, commissioning, maintenance contracts, and technical training for fixtures and systems. In addition, this team plays a large role in Systems sales, responsible for administering final commissioning, record-keeping, and organizing services. Refer to the back cover of this user manual for contacts in your region or visit [WWW.VARI-LITE.COM/SUPPORT](http://WWW.VARI-LITE.COM/SUPPORT).

## CUSTOMER SERVICE

Customer Service is responsible for boxed goods and spare parts quotations, order entry and fulfilment, project delivery, lead times, and general account management. They also manage all after sales warranty fulfilment, RGA, and repairs invoicing in tandem with our After Sales Service & Support team. Visit our website to find a customer service agent in your region.

## ADDITIONAL DOCUMENTATION

Additional product documentation, including DMX maps, software, and photometric reports, is available for download on our website.

For more information on installing DMX512 control systems, the following publication is available for purchase from the United States Institute for Theatre Technology (USITT), "Recommended Practice for DMX512: A Guide for Users and Installers, 2nd edition" (ISBN: 9780955703522).

USITT Contact Information:

USITT

315 South Crouse Avenue, Suite 200

Syracuse, New York 13210-1844 USA

Phone: 800-938-7488 or +1-315-463-6463

Fax: 866-398-7488 or +1-315-463-6525

Website: [www.usitt.org](http://www.usitt.org)

## ABOUT THIS DOCUMENT

---

Read all instructions before installing or using this product. Retain this user manual for future reference.

Additional product information and descriptions may be found on the product data sheet(s) which can be downloaded from the Vari-Lite website at [WWW.VARI-LITE.COM](http://WWW.VARI-LITE.COM).

This user manual provides necessary information regarding safety, installation, operation and routine maintenance for Vari-Lite VL3200 LT Profile IP. Familiarizing yourself with this information will help you to get the most out of your product.



---

**WARNING:** It is important to read ALL accompanying safety and installation instructions to avoid damage to the product and potential injury to yourself or others.

---

This user manual covers the following model(s):

- VL3200 LT Profile IP; order code(s) 74812-020, 74812-120

## SAFETY WARNINGS AND NOTICES

Read this user manual in full before attempting to install, operate or maintain the fixture to which it relates. This user manual is intended to provide general guidance to such suitably qualified personnel. Installation and operation of the fixture are to be performed by qualified personnel only.

When using electrical equipment, basic safety precautions should always be followed including the following:

### READ AND FOLLOW ALL SAFETY INSTRUCTIONS.

- Fixtures must be installed per the IP rating as marked on the unit. Failure to follow those markings may cause an unsafe condition and void warranty.
- Use safety tether when mounting.
- Equipment should be mounted in locations and at heights where it will not be readily subjected to tampering by unauthorized personnel.
- Not for residential use. Do not use this equipment for other than intended use.
- Note distance requirement(s) from combustible materials or illuminated objects. Do not mount near gas or electric heaters.
- Install only in locations with adequate ventilation. Ensure sure that ventilation slots are not blocked.
- Ensure that the voltage and frequency of the power supply match the power requirements of the fixture.
- The fixture must be earthed/grounded to the appropriate conductor.
- Do not operate fixture outside the specified ambient temperature range.
- Do not connect the fixture to any dimmer pack.
- The use of accessory equipment not recommended by the manufacturer may cause an unsafe condition and void warranty.
- Refer service to qualified personnel. This fixture contains no user serviceable parts.
- Prior to first use, carefully inspect fixture to ensure no damage has occurred during shipping.
- Materials used in the manufacturing process can cause strong odors when the product is new. These odors dissipate over time.
- Prior to each use, carefully inspect power cables and replace any damaged cables.
- Exterior surfaces of the luminaire will be hot during operation. Take appropriate precautions.
- Continuous use of the fixture may shorten the lifespan. Power down the fixture when not in use.
- Do not cycle power on and off repeatedly. Disconnect mains power if the fixture is not used for an extended period.
- Clean fixtures regularly, particularly when working in a dusty environment.
- Never touch power cables or wires while the fixture is powered on.
- Avoid entangling power wires with other cables.
- In the event of a serious operating problem, immediately discontinue using the fixture.
- It is hazardous to operate luminaires without lens or shield. Shields, lenses, or ultraviolet screens shall be changed if they have become visibly damaged to such an extent that their effectiveness is impaired, for example, by cracks or deep scratches.
- Original packing materials can be reused for transporting the fixture.
- Do not look directly at the LED light beam while the fixture is on.
- This is a Class A product. In a domestic environment this product may cause radio interference, in which case, the user may be required to take adequate measures.
- The light source contained in this luminaire shall only be replaced by the manufacturer or service agent or similarly qualified person.

### SAVE THESE INSTRUCTIONS.



**WARNING:** Refer to National Electrical Code® and local codes for cable specifications. Failure to use proper cable can result in damage to equipment or danger to personnel. Caution Against Direct Sunlight Through Front Lens Assembly

Caution! The luminaire should be positioned so that prolonged staring into the luminaire at a distance closer than 3.5 m is not expected. RG2

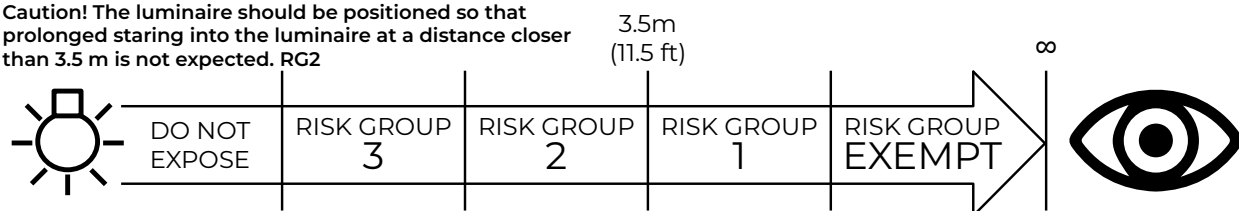

### CAUTION AGAINST DIRECT SUNLIGHT THROUGH FRONT LENS ASSEMBLY

The design and nature of the front lens assembly in Vari-Lite LLC luminaires is to efficiently focus the light energy from the luminaire's lamp for maximum light output.

- When the front lens assembly is exposed to direct sunlight or intense light from neighboring fixtures, the lens will collect and intensify this light and focus it back into the fixture. Intense sunlight or beams from other fixtures can cause damage to internal assemblies contained within the fixture.
- When fixture is not in use and direct sunlight or other intense light is present, position luminaires so their front lens assembly is not directly exposed to the light source.

### CAUTION AGAINST DAMAGED LENSES, SHIELDS OR SCREENS

- Replace shields, lenses or ultraviolet screens if they have become visibly damaged to such an extent that their effectiveness is impaired, for example by cracks or deep scratches

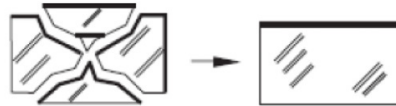

### CAUTION AGAINST POWERING LUMINAIRES FROM DIMMER CIRCUITS

It is not recommended to power any Vari-Lite LLC luminaire from a dimmer - even in 'NONDIM' mode. Dimmer modules are not suitable sources of power because their output modifies the AC wave form. This may work for a short time, but eventually results in power problems, luminaire mis-operation and/or failure. Use constant current or relay modules only.

- When using a power distribution rack, do not use dimmer modules to power any Vari-Lite LLC luminaire. Damage to the luminaire can occur. Use constant current or relay modules only.
- Using a dimmer or non-dim module to power your Vari-Lite LLC luminaire will void your luminaire's warranty.

### CAUTION AGAINST THE USE OF THIRD PARTY PARTS OR ACCESSORIES

- Heat and heat distribution are important factors when operating Vari-Lite LLC luminaires. Vari-Lite LLC luminaires are designed to dissipate heat efficiently and safely. Any blockages or obstructions, such as aftermarket baffles, covers, enclosures, etc. can interrupt the luminaire's ability to dissipate heat properly and can damage the luminaire.
- Vari-Lite LLC cannot be responsible for issues arising from non-approved parts and accessories installed on or used with any Vari-Lite LLC product. Customers of such products should contact the manufacturer directly for assistance and support.

## TRANSPORTING LUMINAIRES

When shipping or transporting luminaires, Vari-Lite LLC recommends that the luminaire(s) be sufficiently protected against any (including, but not limited to) shock, vibration, drops, jarring, exposure to the environment, etc.

Failure to sufficiently protect any Vari-Lite LLC luminaire during shipping or transportation will result in damage and void the luminaire's warranty. Vari-Lite LLC will not be responsible for any shipping damage or breakage of any product under any circumstances. Vari-Lite LLC will not be responsible for any third party case manufacturer's cases.



**NOTE:** As with all automated luminaires, proper handling and suitable protective shipping cases should be used when transporting fixtures to reduce the risk of damage.

### TRANSPORTATION AND SHIPPING CASE REQUIREMENTS

Cases to transport Vari-Lite LLC luminaires should meet the following loading requirements:

- Luminaire head, yoke, and enclosure sub-assemblies shall be equally supported and constrained where no one sub-assembly (head, yoke, or enclosure) fully supports the entire mass of the luminaire.
- The interior of the case shall be of high quality and uniform density foam. The foam shall be of the same type and density throughout as to equally and uniformly support loading at every contact surface.
- The case shall, when laid on any of its six (6) surfaces, maintain the loading requirements outlined above.
- All cases not meeting the aforementioned loading requirements, with wheels, shall have markings on the exterior of the case that the unit is to be transported on it wheels only (e.g. "Case must be transported and remain [at all times] on its wheels").

## COMPLIANCE NOTICE

---



### FCC DECLARATION OF CONFORMITY

This equipment has been tested and found to comply with the limits for a Class A digital device pursuant to Part 15 of FCC Rules. These limits are designed to provide reasonable protection against harmful interference when this equipment is operated in a commercial environment. This equipment generates, uses, and can radiate radio frequency energy and, if not installed and used in accordance with Vari-Lite system, service, and safety guidelines, may cause harmful interference to radio communications.

As tested under this standard:

#### FCC 47CFR 15B

FCC Part 15 Subpart B Class B

Operation of this equipment in a residential area is likely to cause harmful interference, in which case the user will be required to correct the interference at his/her own expense.

### ISED DECLARATION OF CONFORMITY

This equipment has been tested and found to comply with the limits set by ICES-005 Issue 5 Class B as tested under this standard: ANSI C63.4



### RCM DECLARATION OF CONFORMITY

This equipment has been tested and found to comply with the limits set by CISPR 15 of Equipment Regulations as tested under this standard:

AS CISPR 15



### EU DECLARATION OF CONFORMITY

We, Vari-Lite LLC., 10911 Petal Street, Dallas, Texas 75238, declare under our responsibility for the products contained herein are in conformity with the essential requirements of the following European Directives and harmonized standards:

#### Low Voltage Director (LVD)

EN IEC 60598-2-17 used in conjunction with EN IEC 60598-1

#### Electromagnetic Compatibility Directive (EMC)

EN IEC 55015, EN IEC 61000-3-2, EN 61000-3-3, EN 61547



### UK DECLARATION OF CONFORMITY

#### Electrical Equipment (Safety) Regulations

BS EN IEC 60598-2-17 used in conjunction with BS EN IEC 60598-1

#### Electromagnetic Compatibility Regulations

BS EN IEC 55015, BS EN IEC 61000-3-2, BS EN 61000-3-3, BS EN 61547



### ETL AUTHORIZATION TO MARK

Vari-Lite LLC. declares that this product conforms to UL Standard UL 1573 and is certified to CAN/CSA Standard CSA C22.2#166

### GLOBAL CB CERTIFICATION/IECEE

IEC 60598-2-17 used in conjunction with IEC 60598-1

## HOW TO OBTAIN WARRANTY SERVICE

---

A copy of the Limited Warranty card was included in the shipping package for this product.

To obtain warranty service, please contact customer service at 1-214-647-7880, or [entertainment.service@signify.com](mailto:entertainment.service@signify.com) and request a Return Material Authorization (RMA) for warranty service. You will need to provide the model and serial number of the item being returned, a description of the problem or failure and the name of the registered user or organization. If available, you should have your sales invoice to establish the date of sale as the beginning of the warranty period. Once you obtain the RMA, pack the unit in a secure shipping container or in its original packing box. Be sure to clearly indicate the RMA number on all packing lists, correspondence, and shipping labels. If available, please include a copy of your invoice (as proof of purchase) in the shipping container.

With the RMA number written legibly on or near the shipping address label, return the unit, freight prepaid, to:

Vari-Lite LLC  
Attention: Warranty Service (RMA# \_\_\_\_\_)  
10911 Petal Street  
Dallas, Texas 75238  
USA

As stated in the warranty, it is required that the shipment be insured and FOB our service center.



---

**IMPORTANT!** When returning products to Vari-Lite for repairs (warranty or out-of-warranty) from a country other than the USA, “Vari-Lite LLC”, must appear in the address block as the Importer of Record (IOR) on all shipping documentation, Commercial Invoices, etc. This must be done in order to clear customs in a timely manner and prevent returns.

---

# 1 DESCRIPTION

- Long throw production profile luminaire with small footprint and high levels of illumination (>22,000 Lux @ 10m / 4722fc @ 32ft.) – high-output lighting in a compact fixture.
- Optimized long throw optical system offering a 3° to 45° zoom range – tailored zoom for key lighting at distance.
- IP65 outdoor rating – outstanding performance no matter the weather.
- CMY+CTO graduated color wheel mixing system – provides a wide color mixing spectrum with a homogenization of color that completely fills the front lens at all times, improving direct view applications on stage or on camera.
- Full set of fixture features to meet the needs of the most demanding show – two gobo wheels with interchanging gobos, continuous animation wheel, four blade full wipe framing system, iris, frost, and dual prism system which includes both an effects and scenic prism.
- V\*Track Focus System – advanced 16-bit focus control that ensures the edge and zoom remain aligned throughout the full zoom range with no need to switch between controls at the narrowest end of the range.
- V\*Track Calibration\* System – Size and power with none of the unwanted movement. Limit movement during calibration and reduce start up time. reduce risk of the fixture hitting set objects or shaking the rig. \*Patent pending
- Wireless DMX using Lumen Radio CRMX TiMo RX™ – cable-free connection of your DMX / RDM data to the fixture fitted as standard. Dynamic wireless system that ensures an improved cognitive coexistence across wireless networks.

For detailed product information, please refer to the Product Guide at <https://www.vari-lite.com/global/products/vl3200-lt-profile-ip>

Download the product datasheet(s) from the Vari-Lite website at [WWW.VARI-LITE.COM](http://WWW.VARI-LITE.COM) for the full technical specifications.

# 2 INSTALLATION & SETUP

## POWER AND DATA CABLING REQUIREMENTS

### CONNECTING POWER

This fixture requires standard AC power distribution from 100-240VAC, 50/60 Hz. Current required depends on the AC supply voltage and product model



**NOTE:** The mating True1 IP 65 compatible connector is supplied; however, you will need to purchase or construct a cable appropriate for your application.

Depending on the application, the luminaire's AC input cable may require a different connector. If required, install a new connector meeting your requirements using the following wire color code reference:

WIRE*	CONNECTION
Green/yellow	AC ground
Blue	AC neutral
Brown	AC line

\* International (Harmonized) Standard

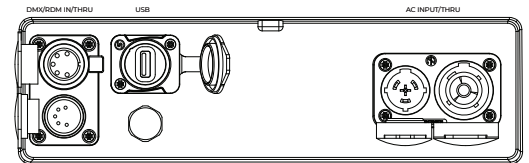

**WARNING:** DO NOT connect to three-phase service in countries with 240V power.

For single-phase power from 100-240 volts RMS:

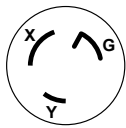

CONNECTION	PIN
AC neutral	X
AC line	Y
Ground (earth)	G

For three-phase power at 208 volts RMS:

CONNECTION	PIN
Phase 1	X
Phase 2	Y
Ground (earth)	G

### CURRENT VERSUS VOLTAGE

**TABLE 1** provides the luminaire's current draw at specific voltages. Total luminaire current is calculated with the lamp on and all motors sequencing.



**WARNING!** It is the responsibility of the user to adequately protect supply source with a correct size and type circuit breaker and not overload circuits.



**WARNING!** It is not recommended to power any Vari-Lite luminaire from a dimmer - even in 'NONDIM' mode. Dimmer modules are not suitable sources of power because their output modifies the AC wave form. This may work for a short time, but will eventually result in power problems, luminaire mis-operation and/or failure and may void the luminaire's warranty. Use constant current or relay modules only.

**TABLE 1. CURRENT VS. VOLTAGE**

AC VOLTAGE	VL3200 LT IP PROFILE
120V/60Hz	6.19A
180V/60Hz	4.07A
208V/60Hz	3.55A
230V/50Hz	3.66A
240V/50Hz	3.12A
264V/50Hz	2.88A
277V/60Hz	2.78A

## DATA CABLE - DMX512/RDM

The luminaire is equipped with two, 5-pin XLR connectors for DATA IN and DATA THRU (out) applications. DATA IN requires a 5-pin, female XLR connector and DATA THRU requires a 5-pin, male XLR connector. When purchasing or constructing data cable, it is important that not only the correct cable type be used, but also quality cable to ensure a reliable DMX512 system. All cable must be IP65 rated or higher. Your cabling should meet the following USITT DMX specification requirements:

- Suitable for use with EIA485 (RS485) operation at 250k baud
- **MUST BE IP65 RATED OR HIGHER - see below**
- Characteristic impedance 85-150 ohms, nominally 120 ohms
- Low capacitance
- Two twisted pairs
- Foil and braid shielded
- 24 AWG min. gauge for runs up to 1000 feet (300m)
- 22 AWG min. gauge for runs up to 1640 feet (500m)



**NOTE:** Microphone type cable and other general purpose, two-core audio or signal cable are not suitable for use with DMX512.

Refer to the USITT Recommended Practice for DMX512 guide for additional information regarding DMX512 systems.

The XLR 5-pin connectors should be wired as follows:

### RECOMMENDED CABLE TYPES/MANUFACTURERS

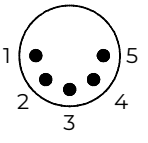
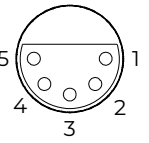
Pin/Wire Code to XLR Connectors						
Data Thru Cable Pinout	Pin 1	Pin 2	Pin 3	Pin 4	Pin 5	Data In Cable Pinout
	Foil & Braided Shield	1st conductor of 1st twisted pair	2nd conductor of 1st twisted pair	1st conductor of 2nd twisted pair	2nd conductor of 2nd twisted pair	
Male Conn.		Data (-)	Data (+)	Data (-)	Data (+)	Female Conn.

These are only a few of the suitable cable types. Any quality EIA485, twisted pair, 120 ohm, shielded cable will also work. Refer to [TABLE 2](#).

## IP65 CONNECTORS

IP65 rated connectors can include, but are not limited to

- NEUTRIK TOP Series
- Seetronic W Series



**NOTE:** Check cable o-ring and rubber seals prior to use. If damaged or missing required lubricant then the cable should not be used.

**TABLE 2. RECOMMENDED CABLES**

TYPE	PAIRS	ZΩ*	JACKET	AWG	USE	TEMP (°F)	TEMP (°C)
<b>BELDEN CABLES</b>							
1215A	2	150	PVC	26	IBM Type 6 Office cable	75	24
1269A	2	100	PTFE	22 (solid)	High Temp, Plenum cable	200	93
8102	2	100	PVC	24	UL2919	80	27
8132	2	120	PVC	28	UL2919	80	27
8162	2	100	PVC	24	UL2493	60	16
82729	2	100	PTFE	24	High Temp, Plenum cable	200	93
88102	2	100	PTFE	24	High Temp, Plenum cable	200	93
89696	2	100	PTFE	22	High Temp, Plenum cable	200	93
89729	2	100	PTFE	24	High Temp, Plenum cable	200	93
89855	2	100	PTFE	22	High Temp, Plenum cable	200	93
9729	2	100	PVC	24	UL2493	60	16
9804	2	100	PVC	28	UL2960	60	16
9829	2	100	PVC	24	UL2919	80	27
9842	2	120	PVC	24	UL2919	80	27
<b>PROPEX CABLES</b>							
PC224P	2	110	Polyurethane	22	Heavy Duty and Portable	105	41
PC224T	2	110	PVC	22	UL2464	105	41
PC226T	3	110	PVC	22	UL2464		

\* Characteristic impedance

### TERMINATION CONNECTOR

A XLR termination connector is required at the last luminaire (or “far end of the line”) to prevent signal reflections. Signal reflections may cancel out the signal at certain line lengths, resulting in errors. The terminator is also necessary for software downloads and running tests on multiple luminaires. To construct your own connector, you will need the following components:

- 5-pin, male XLR connector.
- Two 1/4W 5% 120 ohm resistors.

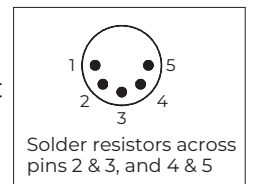

**NOTE:** A male termination connector is available as an accessory from Vari-Lite.

### DATA CABLES - NETWORK/RJ45

The luminaire is equipped with two RJ45 Ethernet compatible connectors. This pair of connectors include a passive pass-thru that will allow signal to pass even if one unit is powered down. Cables should be Cat5, Cat5e or Cat6 and should be equipped with IP65 or higher rated etherCON compatible connectors.

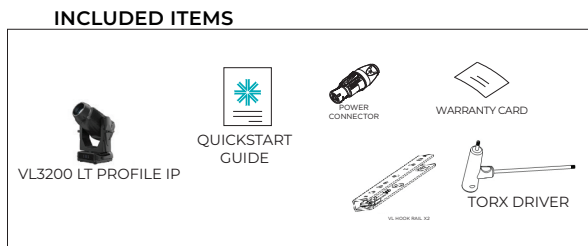

**TABLE 3. INCLUDED ITEMS**

## HANGING THE FIXTURE

The VL3200 LT Profile IP can be hung in any orientation from any structure designed to work with the type of load created by this moving luminaire. Two mounting truss hooks or other mounting hardware are required. Many compatible truss hooks are available from different manufacturers for your particular needs.

A minimum of two hooks per luminaire is required. If mounting method does not use truss hooks, two attachment points, per luminaire, are required.

### Install mounting hardware and brackets:

Step 1. Install truss hooks on two provided truss hook brackets as required as shown.

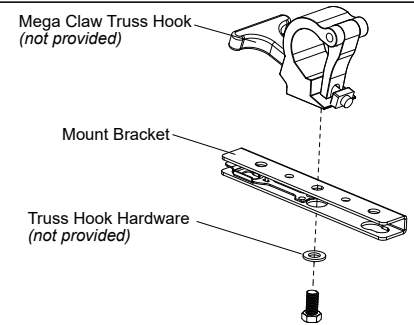

**NOTE:** Various types of truss hooks can be used. The Mega Claw truss hook (as shown in the example above) as well as many other standard hooks, can be ordered separately.



### TRUSS HOOK HARDWARE (BY OTHERS)

When installing hanging hooks on mounting brackets, Vari-Lite strongly recommends the use of a Belleville washer when installing a truss hook or claw. The Belleville washer's size should be approximately 13-25mm (0.5-1.0 in) diameter. Belleville washers are available in various thicknesses and any of the following thicknesses are acceptable for the application described: 0.9mm, 1.0mm, 1.3mm, 1.9mm (0.035-inch, 0.043-inch, 0.050-inch, 0.073-inch).

The washer serves two purposes:

- **To spread out the load.** When a washer IS NOT used, the bolt head (without a washer) concentrates the load in a smaller area, creating focused stress on the steel bracket, making premature failure possible. A steel washer is recommended to spread this load over a larger surface area.
- **To keep the bolt in place.** The recommended Belleville washer maintains tension in the bolted assembly and prevents it from vibrating loose.

If a Belleville washer is not available, a regular flat washer measuring in diameter of 25mm (1 inch) minimum can be used in conjunction with a suitable split lock washer situated between the bolt head and flat washer.

Step 2. Determine required configuration of bracket installation. Brackets may be installed in many different orientations.

Step 3. While pulling up on locking mechanism release, fit keyed holes onto raised mounting buttons at bottom of enclosure. Slide forward and release locking mechanism to lock in place. Ensure brackets are locked securely.

**WARNING:** Ensure that the bracket locking mechanism is fully seated after the bracket is installed on the luminaire.



### Installing in Truss:

Step 1. Using two people, lift luminaire into mounting position.

Step 2. Secure in place with truss hook. Ensure truss hook hardware that locks hook in place (e.g. wing bolt) is properly tightened and that luminaire is fully supported.

Step 3. Attach safety cable (as required) as follows:

- Loop safety cable at least once around safety cable anchor point rod.
- Loop safety cable at least once around truss/pipe and secure around pipe.

Step 4. Make sure tilt and pan locks are disengaged so luminaire moves freely.

Step 5. Connect power and data cables.

When the fixture is mounted in a side hanging orientation, you must enable side hang in the menu for proper operation. To enable side hang, press MENU. Select CONFIG > MOVEMENT > SIDE HANG > ENABLE.



### FLOOR MOUNTING

All luminaires included in this manual are designed to sit directly on its base in a floor installation application. When used in this type of application, be sure to leave enough space around the luminaire to allow proper, uninterrupted airflow for cooling and movement.

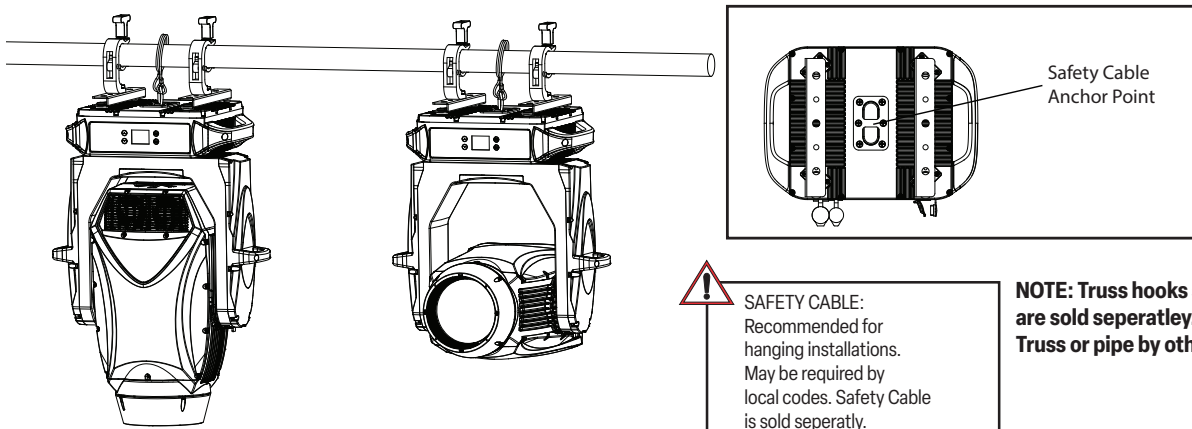
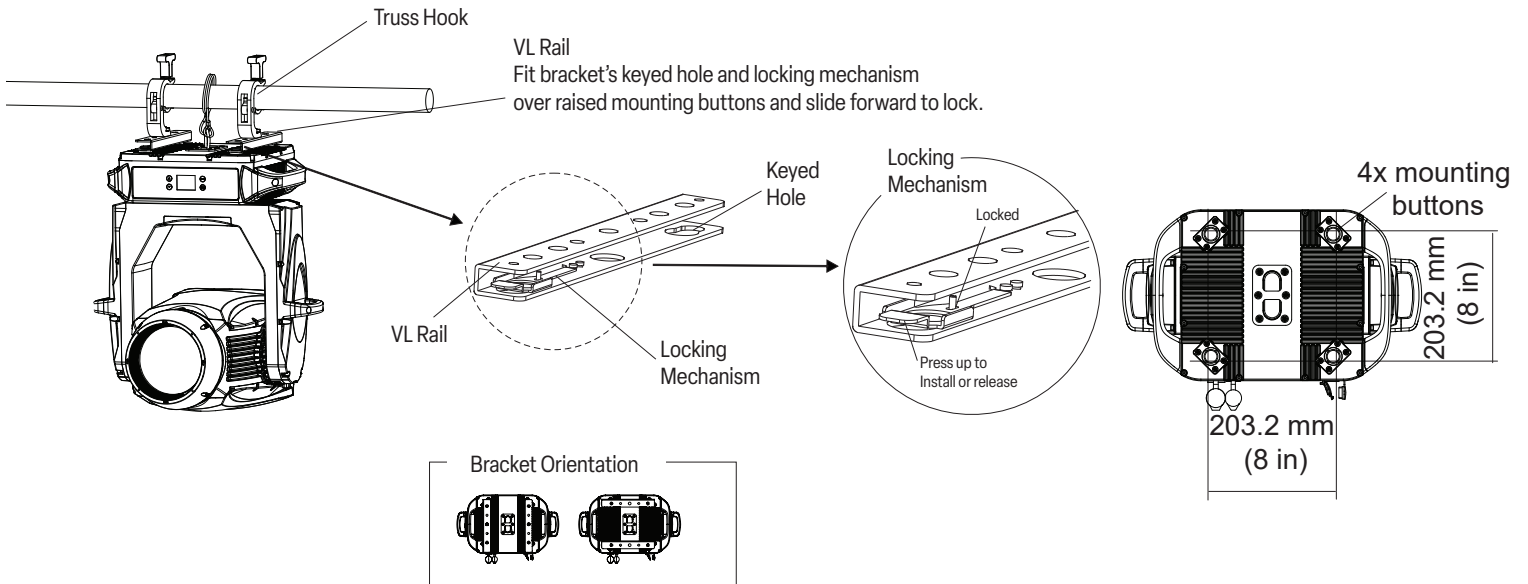
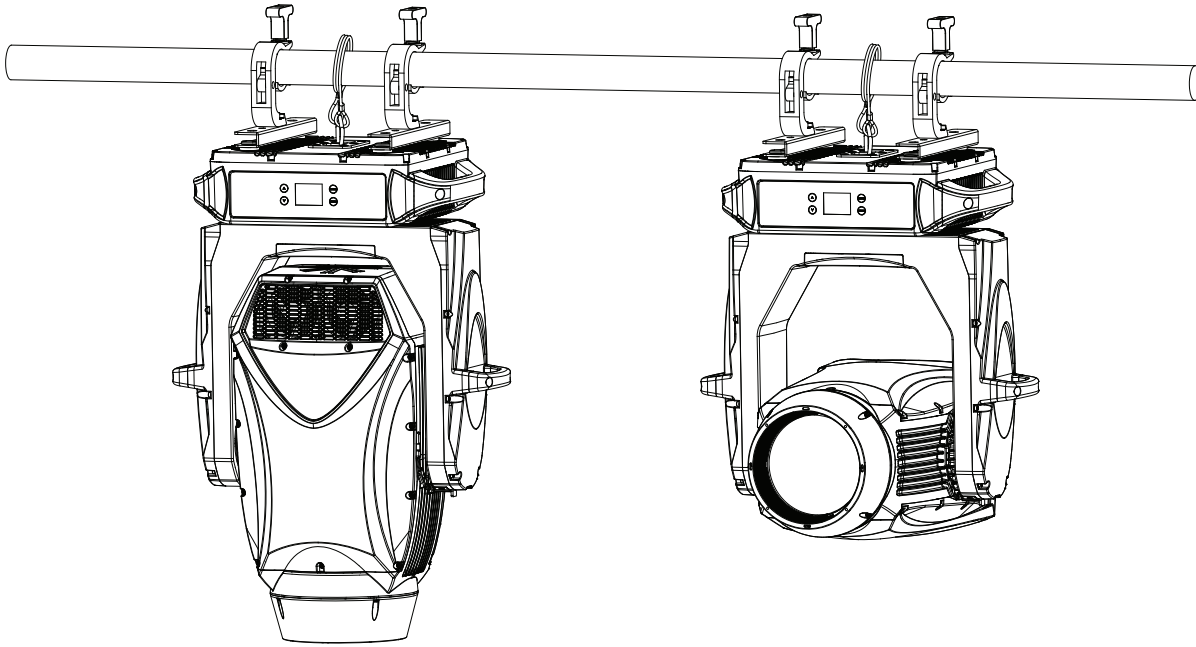

**!** SAFETY CABLE: Recommended for hanging installations. May be required by local codes. Safety Cable is sold separately.

**NOTE: Truss hooks shown are sold separately. Truss or pipe by others.**

## CONNECTING DATA AND POWER

A maximum of 32 luminaires may be connected in any one DMX data link.



**NOTE:** This maximum limit applies to the luminaire “daisy chain” only. Your system or console may require fewer luminaires on a single data link path. Consult your console documentation for more information.

### To connect power and data:

- Step 1. Connect data cable from console to first luminaire in chain at DATA IN connector.
- Step 2. If required, connect additional data cables from DATA THRU connectors to DATA IN connectors of remaining luminaires in link.
- Step 3. At last luminaire in link, install male termination connector at DATA THRU connector. (Luminaires and other devices on the same DMX chain may not function properly without termination.)
- Step 4. Connect AC Input Cable connector to power input source.
- Step 5. Dress AC input and data cables and secure them so that they will not interfere with luminaire head and yoke movement.

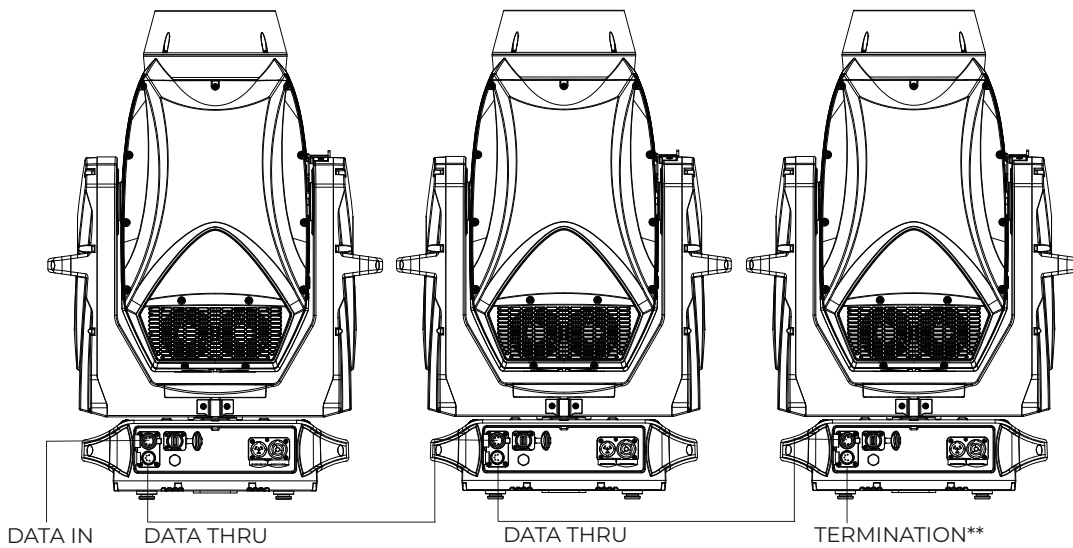

**WARNING!** It is not recommended to power any Vari-Lite luminaire from a dimmer - even in 'NONDIM' mode. Dimmer modules are not suitable sources of power because their output modifies the AC wave form. This may work for a short time, but will eventually result in power problems, luminaire mis-operation and/or failure and may void the luminaire's warranty. Use constant current or relay modules only.

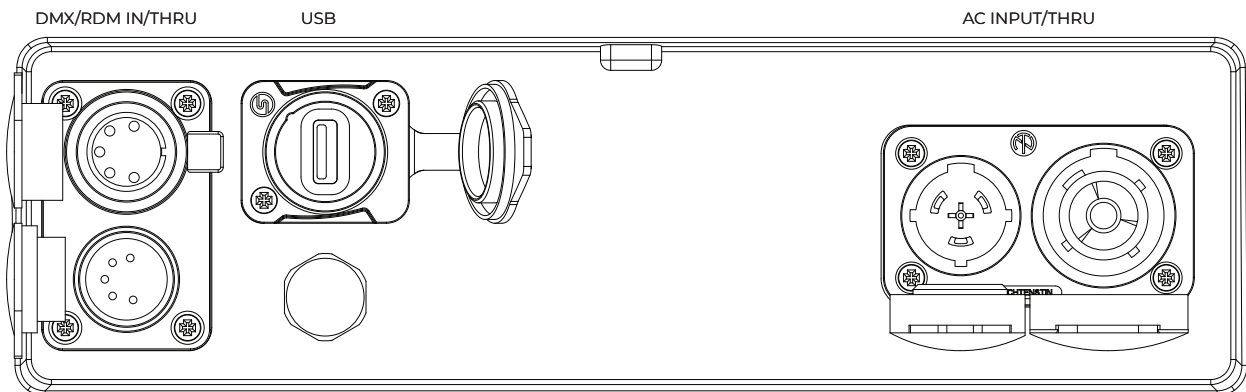

## POWERING UP

### POWER-UP PROCEDURE

When AC power is applied, the luminaire immediately begins a calibration sequence. Pan and Tilt will either move direct to the home position or to the current DMX values depending on menu settings. The internal color and beam mechanisms will also move through a full range of motion. After calibration, the luminaire head will either stop at its “home” position (which positions the pan axis at mid-rotation and the head parallel to the yoke with the lens pointing away from the luminaire enclosure) or move to its current DMX-defined position if DMX data is present. All internal mechanisms also move to their “home” or DMX-defined positions.



**CAUTION:** Before applying power, be sure the luminaire is hung (or positioned), and the pan and tilt locks are disengaged, so that the head and yoke can move freely without restriction.

#### To power up:

- Step 1. At each luminaire, apply power connecting the power cable to the unit.
- Step 2. Luminaire automatically steps through calibration and stops at “home” position (only if DMX is not present).

## ADDRESSING

### PROGRAM STARTING ADDRESS

The address setting for DMX console controlled systems is entered using the Menu Display. The luminaire retains the DMX address even if power is removed.

#### DMX ADDRESS

##### To set, edit, and save a DMX address:

- Step 1. Press [MENU].
- Step 2. Press [UP] / [DOWN] arrows until Address appears. Press [ENTER].
- Step 3. Use [UP] and [DOWN] arrow buttons to scroll through all available starting address.
- Step 4. Once correct starting address is selected, press [ENTER] to set..



**NOTE:** The luminaire has an auto lock function on the Menu Display. To unlock, while touching the ENTER button, touch UP -> DOWN -> UP -> DOWN if unit is sitting. If hanging, while touching the ENTER button, touch DOWN -> UP -> DOWN -> UP.

### PROGRAM STARTING ADDRESS WITHOUT CALIBRATION

It is possible to bypass the calibration sequence and go directly to the Menu Display programming in order to pre-program an address setting.

To program starting address without calibrating luminaire:

- Power the luminaire on. As soon as the display says ‘Calibrating’ touch and hold the MENU button.
- After a few seconds, release the menu button and then program address as in Program Starting Address above.



**NOTE:** The luminaire will require a reset to restore control.

Program starting address in Battery Mode:

- To activate menu in Battery Mode when the fixture is not connected to a power source, touch and hold the MENU button, and at same time press and hold the battery enable button on the rear. Once the screen boots you can release both and access menu normally. Pressing the MENU button from the top level or home screen will shutoff display.

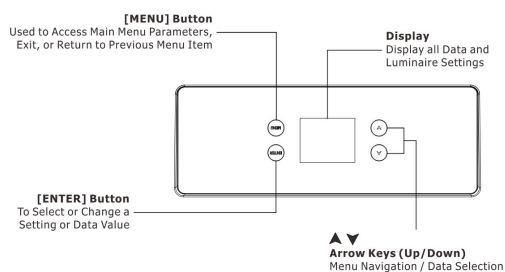

## TRANSPORTING

---

When shipping or transporting luminaires, Vari-Lite recommends that the luminaire(s) be sufficiently protected against any (including, but not limited to) shock, vibration, drops, jarring, exposure to the environment, etc.

Failure to sufficiently protect any Vari-Lite luminaire during shipping or transportation will result in damage and void the luminaire's warranty. Vari-Lite will not be responsible for any shipping damage or breakage of any product under any circumstances. Vari-Lite will not be responsible for any third-party case manufacturer's cases.



**NOTE:** As with all automated luminaires, proper handling and suitable protective shipping cases should be used when transporting fixtures to reduce the risk of damage. For more information, please refer to Vari-Lite technical notice (TN-235) "Transportation and Shipping Case Requirements" in the "Support" area of the Vari-Lite web site.

---

## TRANSPORTATION AND SHIPPING CASE REQUIREMENTS

Cases to transport Vari-Lite luminaires should meet the following loading requirements:

- Luminaire head, yoke, and enclosure sub-assemblies shall be equally supported and constrained where no one sub-assembly (head, yoke, or enclosure) fully supports the entire mass of the luminaire.
- The interior of the case shall be of high quality and uniform density foam. The foam shall be of the same type and density throughout as to equally and uniformly support loading at every contact surface.
- The case shall, when laid on any of its six (6) surfaces, maintain the loading requirements outlined above.
- If using the provided SIP, ensure it fits securely into the case.
- All cases not meeting the aforementioned loading requirements, with wheels, shall have markings on the exterior of the case that the unit is to be transported on it wheels only (e.g. "Case must be transported and remain [at all times] on its wheels").

# 3 OPERATION

## COLOR WHEEL

The VL3200 LT Profile IP each contains one fixed color wheel.



**NOTE:** Fixed colors can only be changed by an authorized service center.

Color Wheel

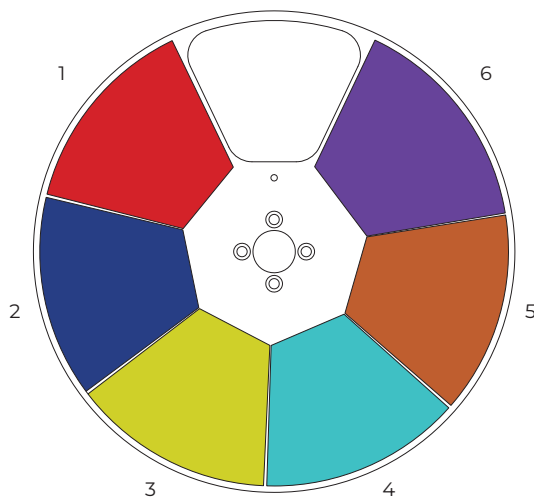

SLOT	DMX RANGE	CENTER
1	32 - 63	48
2	64 - 95	80
3	96 - 127	112
4	128 - 159	144
5	160 - 191	176
6	192 - 223	208

## ANIMATION WHEEL



**NOTE:** VL\*FX Wheel images can only be changed by an authorized service center.

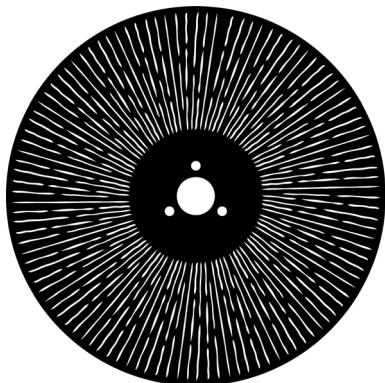

## GOBO WHEEL

The VL3200 LT Profile IP accommodates glass gobos. There are two wheels, with Gobo Wheel 1 offering 8 fixed gobos plus one open position and Gobo Wheel 2 offering 8 rotatable, indexable gobos plus one open position.

### Gobo Wheel 1



1. Leafy Breakup



2. Medium Circle

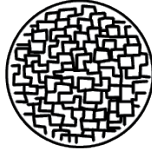

3. Square Pile

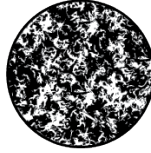

4. Dust



5. Neurons



6. Radial Breakup



7. Blobs



8. Staples

GOBO SLOT		
	DMX RANGE	CENTER OF IMAGE
<b>1</b>	<b>26 - 51</b>	<b>38</b>
<b>2</b>	<b>52 - 77</b>	<b>64</b>
<b>3</b>	<b>78 - 103</b>	<b>90</b>
<b>4</b>	<b>104 - 129</b>	<b>116</b>
<b>5</b>	<b>130 - 155</b>	<b>142</b>
<b>6</b>	<b>156 - 181</b>	<b>168</b>
<b>7</b>	<b>182 - 207</b>	<b>194</b>
<b>8</b>	<b>208 - 233</b>	<b>220</b>



**CAUTION:** VL3200 LT Profile IP accepts glass gobos only. Use of metal gobos in these luminaires may damage gobo assembly and will void the luminaire warranty.

## Gobo Wheel 2



1. Night Sky



2. New Twirler



3. Bricked Out

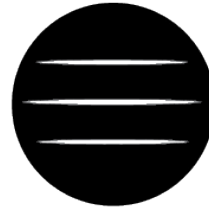

4. Horizontal Slits

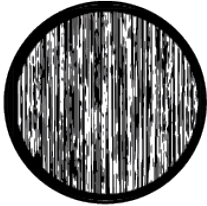

5. Super Alpha Rays



6. Honey Comb Reverse

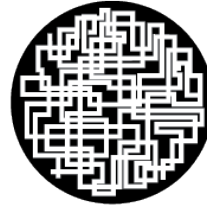

7. Pipes Breakout



8. On the Rocks

GOBO SLOT	INDEX		ROTATION		MEGA STEPPING	
	DMX RANGE	CENTER OF IMAGE	DMX RANGE	CENTER OF IMAGE	DMX RANGE	CENTER OF IMAGE
1	9 - 17	13	90 - 98	94	171 - 179	175
2	18 - 26	22	99 - 107	103	180 - 188	184
3	27 - 35	31	108 - 116	112	189 - 197	193
4	36 - 44	40	117 - 125	123	198 - 206	200
5	45 - 53	47	126 - 134	130	207 - 215	210
6	54 - 62	60	135 - 143	139	216 - 224	220
7	63 - 71	67	144 - 152	150	225 - 233	230
8	72 - 80	78	153 - 161	158	234 - 242	240

GOBO	MATERIAL	REFLECTION	THICKNESS	OUTER SIZE	IMAGE SIZE	CARRIER
Rotating Gobo Black and White, VL3200 LT Profile IP	Corning glass with aluminum & titanium film	>88%	1.1mm*	20mm	16mm	Yes
Rotating Gobo On the Rocks	high-temp glass	0%	2.5mm	20mm	16mm	Yes
Fixed Gobo Black and White, VL3200 LT Profile IP	Corning glass with aluminum & titanium film	>88%	1.1mm*	20mm	16mm	Yes

\*Custom glass gobos thicker than 1.1mm should be installed into the carrier and secured in place with a high quality clear silicon RTV in lieu of the stock conical spring. Vari-Lite recommends 'Loctite Brand 5083 Translucent Dual-Cure Silicon Adhesive'. The maximum height of the Rotating Gobo Carrier is 4.8mm, and the maximum height for the Fixed Gobo Carrier is 2.8mm. The specified maximum height shall include the gobo and the silicon RTV

Compatible carriers for gobos are shown below.

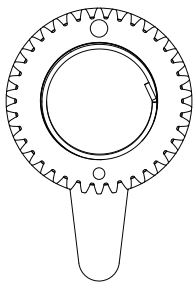

Rotate Gobo Carrier with Magnet  
3033003089

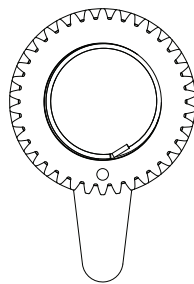

Rotate Gobo Carrier  
3033003090

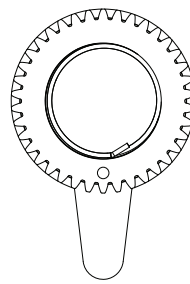

Rotate Gobo Carrier On The Rocks  
3033003091

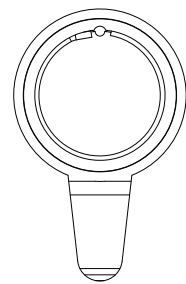

Fixed Gobo Carrier  
3033003088

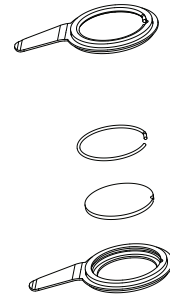
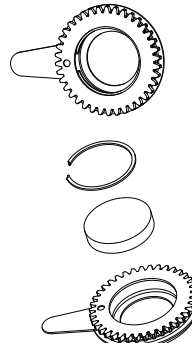
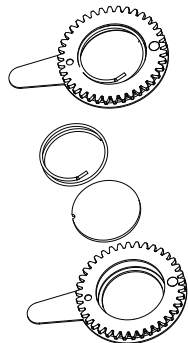
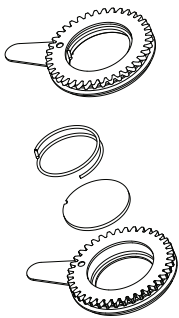

## REMOVE AND INSTALL LUMINAIRE COVERS



**WARNING:** This procedure should only be performed by authorized service personnel. Refer to the VL3200 LT Profile IP Service Manuals for additional details.

VL3200 LT Profile IP luminaires require special attention when the removal of any covers is required. The seals must be inspected, and care taken when replacing the covers.



**WARNING:** Failure to follow instructions may cause damage to unit and void warranty. Only authorized service personnel should attempt.

### To remove head covers:

- Step 1. Remove power from luminaire.
- Step 2. Using a Torx T-20 driver (one is supplied with each luminaire) remove the 13 x M4x12mm SHCP T20 screws at each cover. There is no need to remove the waterproof silicon gasket.



**NOTE:** There is a tether connecting the covers to the luminaire. If removing, use caution when re-attaching to avoid damage to threads.

### To replace head covers (See Fig below):

- Step 1. If gasket has been removed, inspect the groove and remove any residue. Place the flat side of the IP sealing gasket inward and the rounded side outward.
- Step 2. Align the gasket with the groove and install it, again with the flat side in the groove. The rounded side should protrude out of the groove about 1mm.
- Step 3. Install 1 x M4x12mm SHCP T20 screw into position 2 two-thirds of the length.
- Step 4. Install 2 x M4x12mm SHCP T20 screws into positions 9 and 8 two-thirds of the length.
- Step 5. Install 2 x M4x12mm SHCP T20 screw into position 7 and 10 two-thirds of the length.
- Step 6. Install 2 x M4x12mm SHCP T20 screws into positions 1 and 3 two-thirds of the length.
- Step 7. Install the remaining M4x12mm SHCP T20 screws into positions 4,5,6,11,12, and 13 two-thirds of the length.
- Step 8. Tighten positions 1 and 8 to 20 kgf.cm (1.96 Nm / 1.45 lbf.ft)
- Step 9. Tighten positions 3 and 9 to 20 kgf.cm (1.96 Nm / 1.45 lbf.ft)
- Step 10. Tighten all remaining positions 2,4,5,6,7,10,11,12,13 to 20 kgf.cm (1.96 Nm / 1.45 lbf.ft)



**WARNING:** If the gasket has any damage or 'dents' it must be replaced.

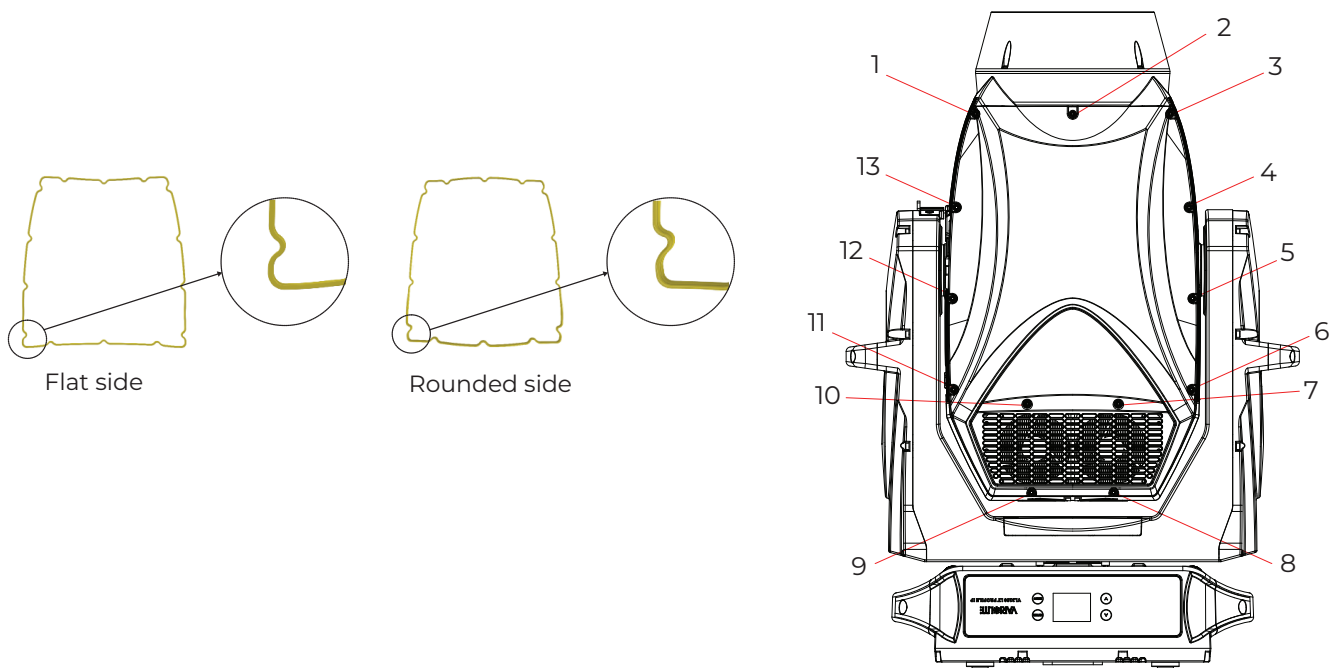

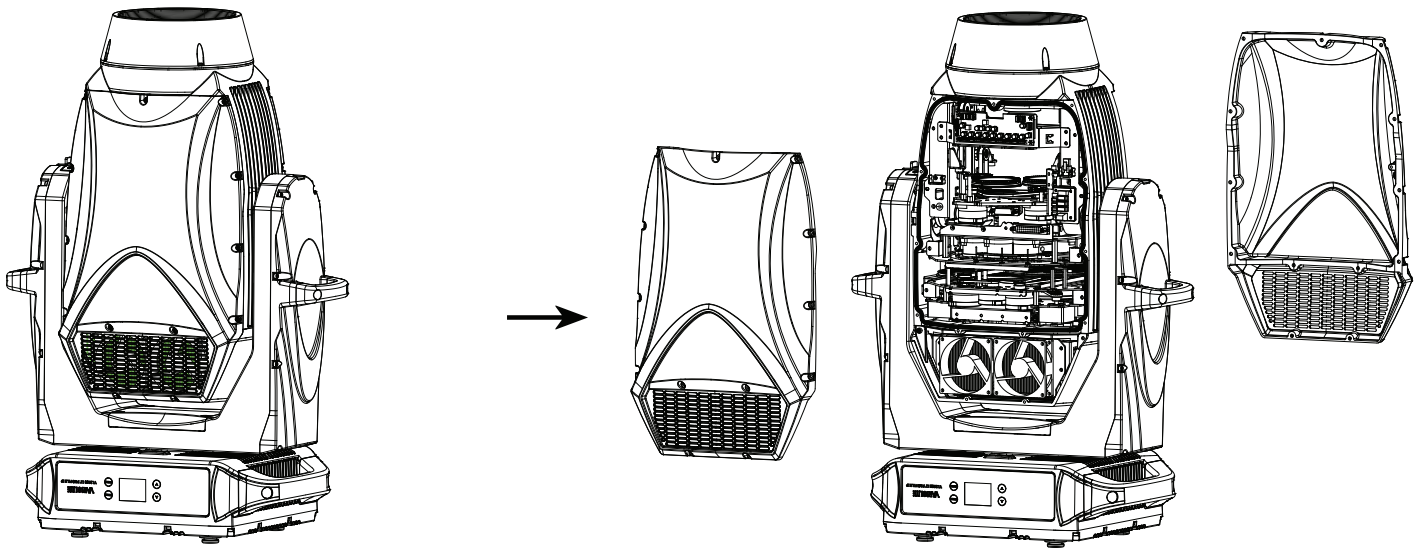

## REPLACE A ROTATING GOBO

### To replace a rotating gobo (see below):

- Step 1. Remove power from luminaire.
- Step 2. Remove top head cover as described on previous page. Top head cover, with fixture sitting on its enclosure, with lens pointing up and tilt lock on your left hand side.

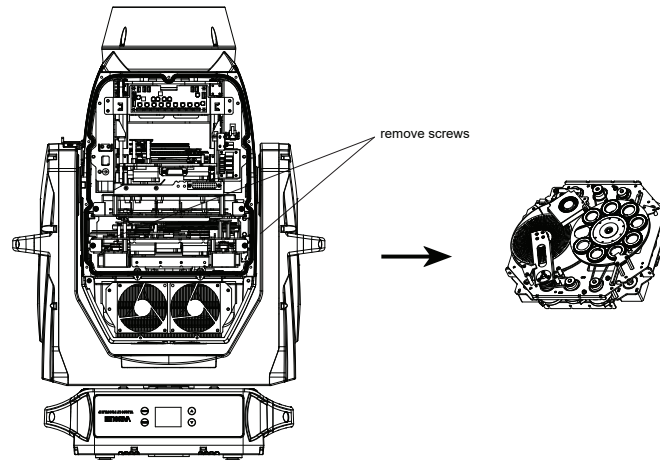

- Step 3. At interconnect board, disconnect 1 x 4pin and 1 x 3pin cable connecting gobo assy
- Step 4. Remove the 2 screws and remove the gobo/color assembly.

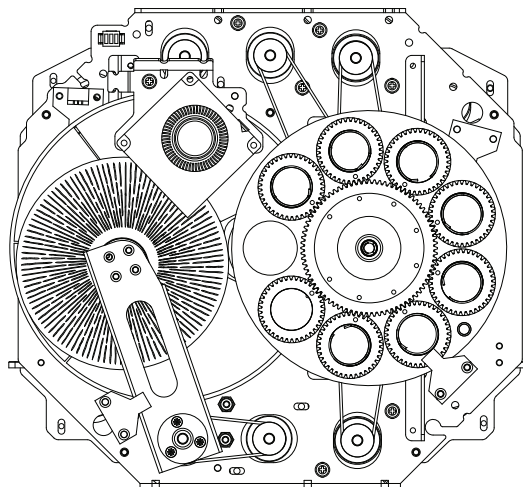

- Step 5. Lift up on the edge of the rotating gobo carrier you wish to remove and slowly pull out.
- Step 6. Remove the Spring at E with an appropriate tool like tweezers. There is some silicon RTV holding the gobo/spring into the carrier, carefully remove it before removing the spring to avoid damage to the gobo.
- Step 7. Do not touch the surface of the gobo with bare fingers (wear gloves). Put the gobo and the spring back into the carrier, aligning the mark on the gobo with the mark on the carrier as shown in F. The coated side should face upwards. Apply a small amount of silicon RTV to hold the gobo in place.
- Step 8. Ensure the sun gear on the gobo wheel is oriented so that all 8 timing marks on the sun gear align with the timing marks on the gobos. If they do not, turn the sun gear until all gobos are aligned.



**NOTE:** Take care when removing wheels as there are spacers present. Ensure you keep track of these and replace in the proper orientation/position.

- Step 9. Insert the gobo holder back into the rotating gobo wheel ensuring the timing mark on the gobo carrier aligns with the timing mark on the sun gear.

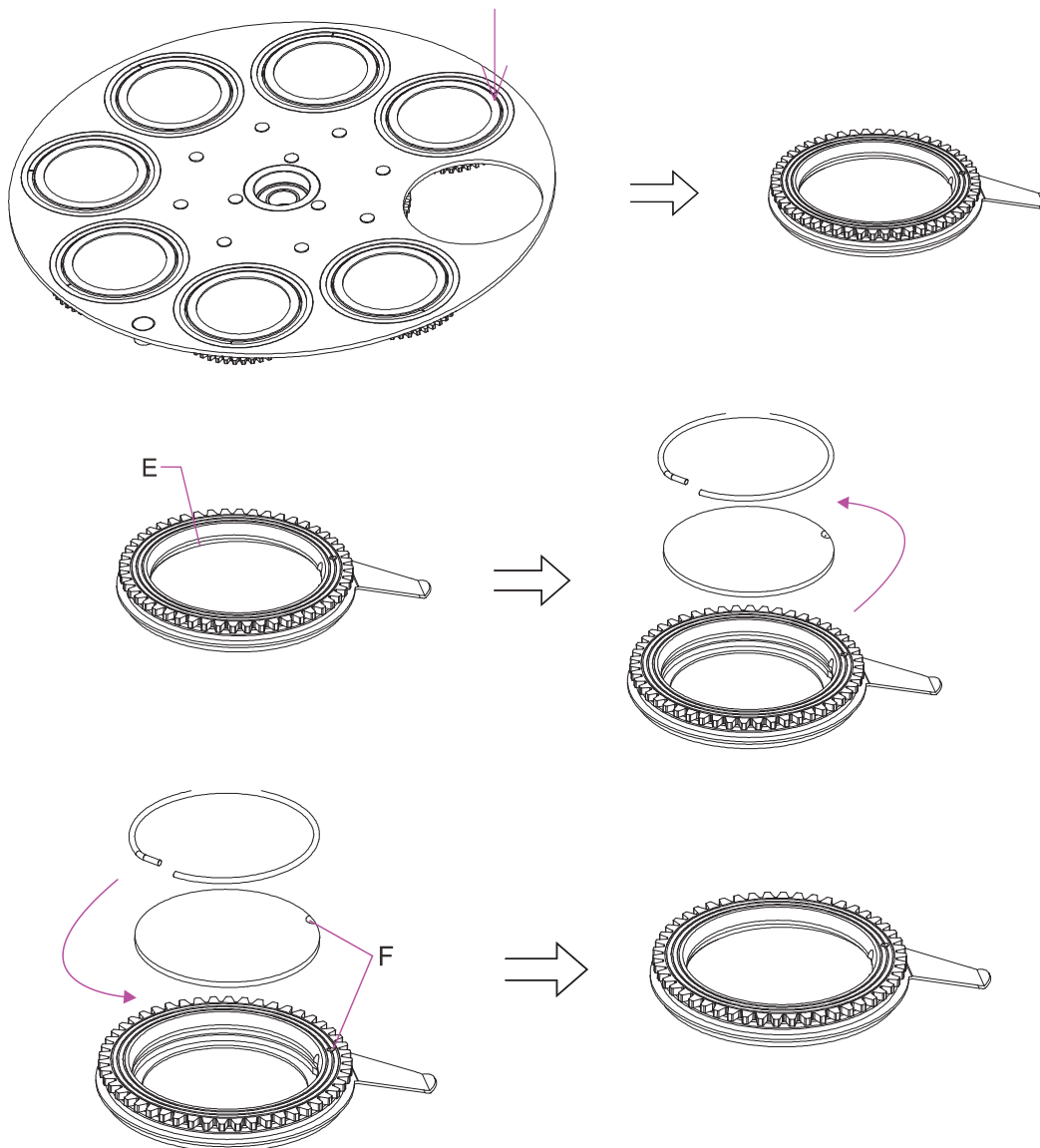

gobo holder  
with magnet

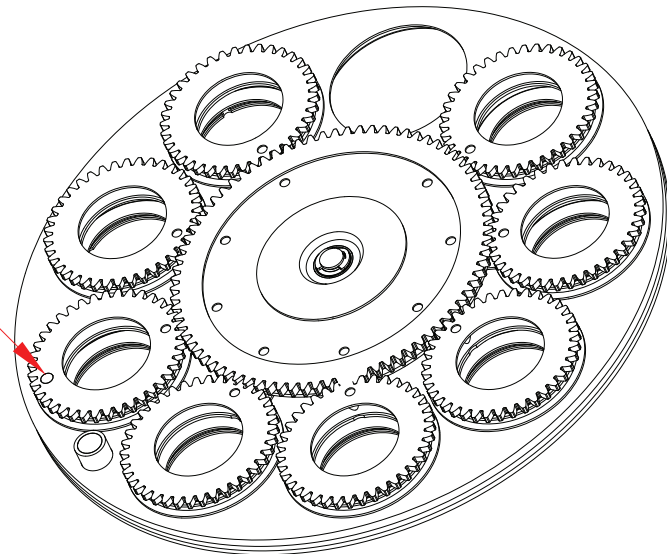

NOTE: Position 6 carrier requires a magnet to calibrate the gobo index/rotation. Always ensure the carrier in that position has a magnet installed.

Step 10. Re-install in fixture. Follow instructions on replacing the covers.

Step 11. Power and test.

## REPLACE A FIXED GOBO

### To replace a fixed gobo (see below):

Step 1. Remove power from luminaire.

Step 2. Remove top and bottom covers as described above.

Step 3. Remove the gobo/color assembly as described above.

Step 4. At bulkhead, remove 5 x M4 and 3 x M3 screws as shown below.

Step 5. Not placement of all cables. Disconnect and remove cable ties as required.

Step 6. Separate the two halves of the assembly.

Step 7. Loosen screws for gobo wheel motors, slide motors towards wheels and remove belts from drive pulley

Step 8. Carefully flip gobo assembly half over

remove 5-M4,3-M3  
screws

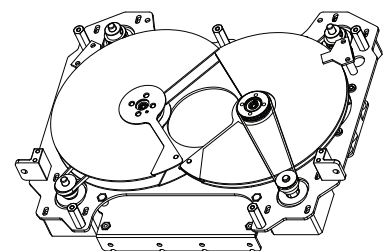
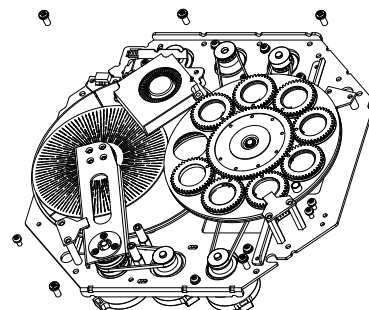
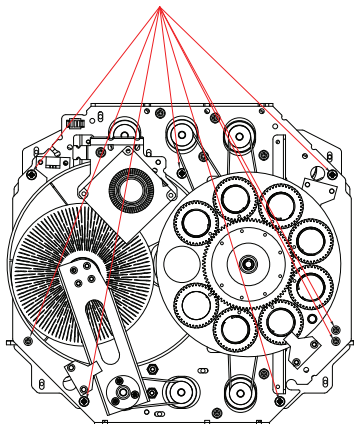

- Step 9. Remove 4 x KM3 screws and remove Rotating/Fixed Gobo wheel from assembly.
- Step 10. Gently lift the fixed gobo carrier you wish to remove from the edge of the gobo wheel and slowly pull it out.
- Step 11. Remove the Spring at C with an appropriate tool like tweezers. There is some silicon RTV holding the gobo/spring into the carrier, carefully remove it before removing the spring to avoid damage to the gobo.

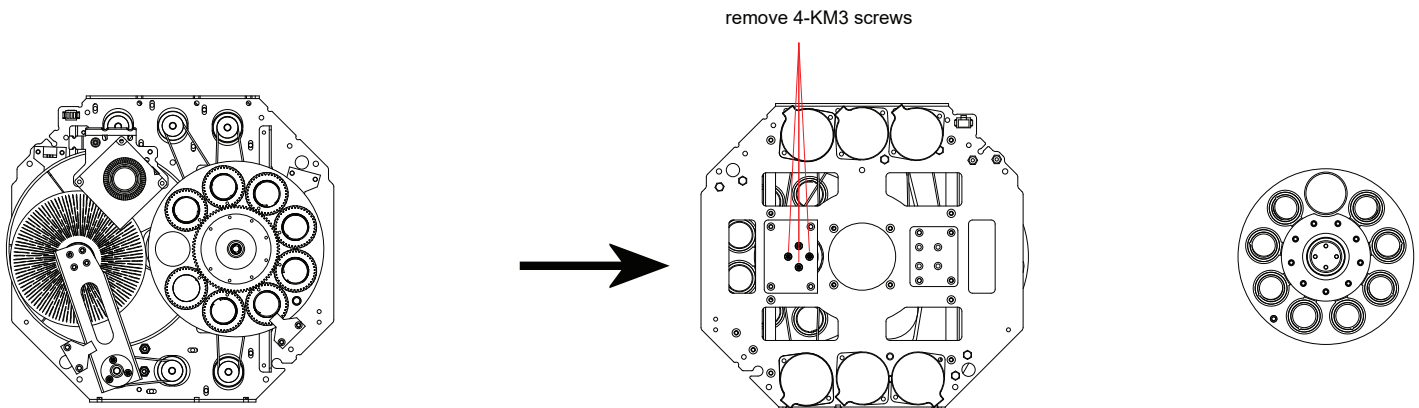

- Step 12. Do not touch the surface of the gobo with bare fingers (wear gloves). Put the gobo and the spring back into the carrier, aligning the mark on the gobo with the mark on the carrier as shown in D. The coated side should face upwards. Apply a small amount of silicon RTV to hold the gobo in place.
- Step 13. Insert the fixed gobo carrier back into the fixed gobo wheel. Re-install the bulkhead into the fixture. Follow the instructions to re-install the covers.
- Step 14. Power and test.

## DMX OPERATION

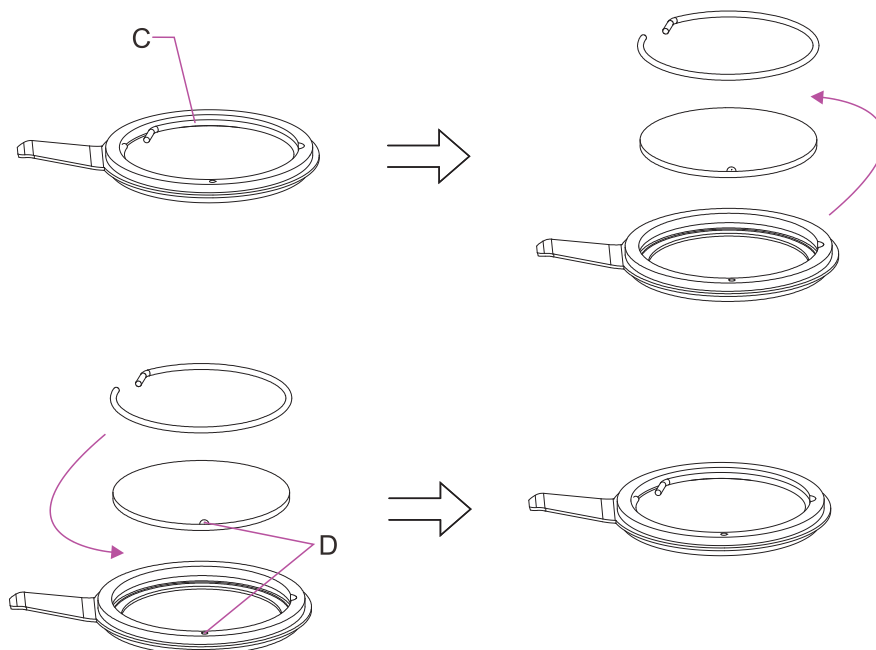

## DMX MAPS

The tables assume a DMX start address of 1. When a different starting address is used, this address becomes channel 1 function and other functions follow in sequence.

DMX CHANNEL		PARAMETER	DEFAULTS	RANGE DMX	DESCRIPTION
16-BIT	16-BIT EXTENDED (DEFAULT)				
1	1	Intensity High	0	0-65535	16-Bit control of Dimming
2	2	Intensity Low			
3	3	Pan High	32767	0-65535	540° Total Pan Rotation
4	4	Pan Low			
5	5	Tilt High	32767	0-65535	270° Total Tilt
6	6	Tilt Low			
7	7	Focus High	32767	0-65535	Focus control Default value 50% Focus range
8	8	Focus Low			
9	9	Zoom High	32767	0-65535	Zoom control Default value 50% zoom range
10	10	Zoom Low			
11	11	Cyan	0	0 - 255	Cyan Color Control 0-100% saturation
12	12	Yellow	0	0 - 255	Yellow Color Control 0-100% saturation
13	13	Magenta	0	0 - 255	Magenta Color Control 0-100% saturation
14	14	CTO Wheel	0	0 - 255	CTO Color Control 0-100% saturation
15	15	Color Wheel 1 (Color Wheel)	0	0 - 255	8-bit control of Color Wheel. (spin speed slow to fast from control channel) OPEN (centered at 0)
				0-31	Open
				32-63	Red Center - 48
				64-95	Dark Blue Center - 80
				96-127	Yellow Center - 112
				128-159	Kelly Green Center - 144
				160-191	Amber Center - 176
				192-223	Congo Blue Center - 208
				224-255	Open
16	16	Color Wheel 1 Control	0	0 - 255	
				0 - 5	Linear Movement using shortest (quickest) path.
				6 - 10	Linear Movement using normal (longest) path.
				11 - 15	Wheel Spin CW (Forward)
				16 - 20	Wheel Spin STOP
				21 - 25	Wheel Spin CCW (Reverse)
				26 - 56	Color Shake Quickest Path (Slow to Fast) For fastest shake set color timing to 0
				57 - 87	Color Shake Normal Path (Slow to Fast) For fastest shake set color timing to 0
				88 - 255	Reserved Values

DMX CHANNEL		PARAMETER	DEFAULTS	RANGE DMX	DESCRIPTION
16-BIT	16-BIT EXTENDED (DEFAULT)				
17	17	Gobo Wheel 1 (Fixed)	0	0-255	8-bit control of Gobo Wheel See channel 19 for control options
				0 - 25	Open - No Gobo
				26 - 51	Gobo 1 Leafy Breakup
				52 - 77	Gobo 2 Medium Circle
				78 - 103	Gobo 3 Square Pile
				104 - 129	Gobo 4 Dust
				130 - 155	Gobo 5 Neurons
				156 - 181	Gobo 6 Radial Breakup
				182 - 207	Gobo 7 Blobs
				208 - 233	Gobo 8 Staples
				234 - 255	Open
18	18	Gobo Wheel 1 Control	0	0 - 255	Used as a control channel for different movement options for Gobo Wheel 1 (Channel 18)
				0 - 5	Gobo Selection using shortest (quickest) path.
				6 - 10	Gobo Selection using normal (longest) path.
				11 - 20	Reserved Values
				21 - 50	Wheel Spin CW Forward (Fast to Slow)
				51 - 60	Wheel Spin STOP
				61 - 90	Wheel Spin CCW Reverse (Slow to Fast)
				91 - 120	Gobo Shake Quickest Path (Slow to Fast) For fastest shake set gobo timing to 0
				121 - 150	Gobo Shake Normal Path (Slow to Fast) For fastest shake set gobo timing to 0
				151 - 180	Reserved Values
				181 - 210	Reserved Values
211 - 255	Reserved Values				
19	19	Gobo Wheel 2	0	0 - 255	8-bit control of Gobo Wheel 2. See channel 21 for Index/Rotation See channel 23 for control options.
				0 - 8	Open - No Gobo
				9 - 17	Gobo 1 Night Sky Index
				18 - 26	Gobo 2 New Twirler Index
				27 - 35	Gobo 3 Bricked Out Index
				36 - 44	Gobo 4 Horizontal Slits Index
				45 - 53	Gobo 5 Super Alpha Rays Index
				54 - 62	Gobo 6 Honey Comb Reverse Index
63 - 71	Gobo 7 Pipes Breakup				

DMX CHANNEL		PARAMETER	DEFAULTS	RANGE DMX	DESCRIPTION
16-BIT	16-BIT EXTENDED (DEFAULT)				
19	19	Gobo Wheel 2 - continued	0	72 - 80	Gobo 8 On the Rocks Index
				81 - 89	Open - No Gobo
				90 - 98	Gobo 1 Night Sky Rotate
				99 - 107	Gobo 2 New Twirler Rotate
				108 - 116	Gobo 3 Bricked Out Rotate
				117 - 125	Gobo 4 Horizontal Slits Rotate
				126 - 134	Gobo 5 Super Alpha Rays Rotate
				135 - 143	Gobo 6 Honey Comb Reverse Rotate
				144 - 152	Gobo 7 Pipes Breakup Rotate
				153 - 161	Gobo 8 On the Rocks Rotate
				162 - 170	Open - No Gobo
				171 - 179	Gobo 1 Night Sky Rotate Mega Stepping
				180 - 188	Gobo 2 New Twirler Rotate Mega Stepping
				189 - 197	Gobo 3 Bricked Out Rotate Mega Stepping
				198 - 206	Gobo 4 Horizontal Slits Rotate Mega Stepping
				207 - 215	Gobo 5 Super Alpha Rays Rotate Mega Stepping
				216 - 224	Gobo 6 Honey Comb Reverse Rotate Mega Stepping
				225 - 233	Gobo 7 Pipes Breakup Mega Stepping
				234 - 242	Gobo 8 On the Rocks Rotate Mega Stepping
243 - 255	Open - No Gobo				
20	20	Gobo Wheel 2 Rotate/Index High Byte	32767	0 - 65535	16-bit control of index and rotation of gobo wheel 2.
				0 - 32756	Rotate Fast to Slow <<<
21	21	Low Byte		32757 - 32780	Rotation STOP
				32781 - 65535	Rotate Slow to Fast >>>
22	22	Gobo Wheel 2 Control	0	0 - 255	Used as a control channel for different movement options for Gobo Wheel 2 (Channel 20)
				0 - 5	Gobo Selection using shortest (quickest) path.
				6 - 10	Gobo Selection using normal (longest) path.
				11 - 20	Reserved Values
				21 - 50	Wheel Spin CW Forward (Fast to Slow)
				51 - 60	Wheel Spin STOP
				61 - 90	Wheel Spin CCW Reverse (Slow to Fast)
				91 - 120	Gobo Shake Quickest Path (Slow to Fast) For fastest shake set gobo timing to 0
				121 - 150	Gobo Shake Normal Path (Slow to Fast) For fastest shake set gobo timing to 0

DMX CHANNEL		PARAMETER	DEFAULTS	RANGE DMX	DESCRIPTION
16-BIT	16-BIT EXTENDED (DEFAULT)				
22	22	Gobo Wheel 2 Control - continued	0	151 - 180	Gobo Twist Quickest Path (Slow to Fast) For fastest twist set gobo timing to 0
				181 - 210	Gobo Twist Normal Path (Slow to Fast) For fastest twist set gobo timing to 0
				211 - 255	Reserved Values
23	23	Animation Wheel	0	0 - 255	Controls Animation Wheel mechanism with following values
				0 - 5	Open
				6 - 10	Index
				11 - 15	Rotate Normal
				16 - 20	Rotate with Mega Stepping
21 - 255	Reserved				
24	24	Animation Rotation	127	0 - 255	8-bit control of Animation rotation and index
				0 - 126	Rotate Fast to Slow <<<
				127	Rotation STOP
				128 - 255	Rotate Slow to Fast >>>
25	25	Iris	0	0-255	Iris size control
				0 - 200	Iris beam size open to closed
				201 - 255	Iris pulse slow to fast
26	26	Frame 1A	0	0 - 255	Controls Framing Shutter 1A from Open (DMX 0) to Full (DMX 255).
27	27	Frame 1B	0	0 - 255	Controls Framing Shutter 1B from Open (DMX 0) to Full (DMX 255).
28	28	Frame 2A	0	0 - 255	Controls Framing Shutter 2A from Open (DMX 0) to Full (DMX 255).
29	29	Frame 2B	0	0 - 255	Controls Framing Shutter 2B from Open (DMX 0) to Full (DMX 255).
30	30	Frame 3A	0	0 - 255	Controls Framing Shutter 3A from Open (DMX 0) to Full (DMX 255).
31	31	Frame 3B	0	0 - 255	Controls Framing Shutter 3B from Open (DMX 0) to Full (DMX 255).
32	32	Frame 4A	0	0 - 255	Controls Framing Shutter 4A from Open (DMX 0) to Full (DMX 255).
33	33	Frame 4B	0	0 - 255	Controls Framing Shutter 4B from Open (DMX 0) to Full (DMX 255).
34	34	Frame Rotate	128	0 - 255	Controls Framing Shutter mechanism from +/- 60°
35	35	Prism 1 (Triangular)	0	0 - 255	Controls Prism mechanism with following values.
				0 - 5	Open
				6 - 10	Index
				11 - 15	Rotate Normal
				16 - 20	Rotate with Mega Stepping
21 - 255	Reserved Values				

DMX CHANNEL		PARAMETER	DEFAULTS	RANGE DMX	DESCRIPTION
16-BIT	16-BIT EXTENDED (DEFAULT)				
36	36	Prism 1 (Index/Rotate) High Byte	32767	0 - 65535	16-bit control of prism rotation and index.
				0 - 32756	Rotate Fast to Slow <<<
37	37	Low Byte		32757 - 32780	Rotation STOP
				32781 - 65535	Rotate Slow to Fast >>>
38	38	Prism 2 (Flat)	0	0 - 255	Controls Prism mechanism with following values.
				0 - 5	Open
				6 - 10	Index
				11 - 15	Rotate Normal
				16 - 20	Rotate with Mega Stepping
			21 - 255	Reserved Values	
39	39	Prism 2 (Index/Rotate) High Byte	32767	0 - 65535	16-bit control of prism rotation and index.
				0 - 32756	Rotate Fast to Slow <<<
40	40	Low Byte		32757 - 32780	Rotation STOP
				32781 - 65535	Rotate Slow to Fast >>>
41	41	Frost	0	0-255	Control of dual frost
				0 - 10	No Frost
				11 - 20	Frost 1 (light)
				21 - 25	Reserved
				26 - 36	Open
			37-255	Reserved	
42	42	Strobe	0	0 - 5	Shutter open
				6 - 10	Shutter closed
				11 - 125	Strobe Slow>>>>>>>>>Fast 0.5Hz-30Hz
				126 - 130	Shutter open
				131 - 245	Strobe Random/Random Sync* Slow>>>>>>>>>Fast
				246 - 250	Shutter open
			251 - 255	Shutter closed *See Programmers channel for mode slection	
43	43	Future use channel	0		Channel reserved for future use

DMX CHANNEL		PARAMETER	DEFAULTS	RANGE DMX	DESCRIPTION
16-BIT	16-BIT EXTENDED (DEFAULT)				
44	44	Programmers Channel	0		Functions do not require 3 second DMX rule, except as noted. Mode will change once DMX level is reached
				0-40	Idle
				41 - 55	Reserved
				56 - 60	Dimmer Snap On
				61 - 65	Dimmer Snap Off (Default)
				66 - 75	Reserved Values
				76 - 80	Edge Tracking On
				81 - 85	Edge Tracking Off (Default)
				86 - 90	Reserved Values
				91 - 95	Color Snap Off (Default)
				96 - 100	Color Snap On (de-activates color timing channel)
				101 - 105	Reserved Values
				106 - 110	Strobe Random (Default)
				111 - 115	Strobe Random Sync
	116 - 255	Reserved Values			
	45	Focus Timing	255	0 - 255	Adjustment of fixture timing to control Pan/Tilt mechanisms. See Timing Channel Values
	46	Optics Timing	255	0 - 255	Adjustment of fixture timing to control lensing mechanisms. See Timing Channel Values.
	47	Color Timing	255	0 - 255	Adjustment of fixture timing to control color mechanisms. See Timing Channel Values.
	48	Beam Timing	255	0 - 255	Adjustment of fixture timing to control beam shaping mechanisms. See Timing Channel Values.
	49	Gobo Timing	255	0 - 255	Adjustment of fixture timing to control gobo mechanisms. See Timing Channel Values.
45	50	Fan Control	0	0 - 255	Dynamically control fan speed vs LED Output operation. Control values as follows . . .
				0-4	Automatic fan/output adjustment (Default)
				05 - 255	Linear control of fan speed and LED max output* DMX 5 =Highest Constant Fan Speed (Standard mode) DMX 255 = Lowest Constant Fan Speed (Whisper mode) * Standard mode only. Function is dec-activated if Studio or Boost modes are selected via Dmx or User Interface **Note channel is deactivated by default. The function requires activation for use. Activation is from the UI or the luminaire control channel

DMX CHANNEL		PARAMETER	DEFAULTS	RANGE DMX	DESCRIPTION
16-BIT	16-BIT EXTENDED (DEFAULT)				
46	51	Luminaire Control	0	0 - 255	Control Channel used for full fixture settings Set discrete value of desired effect, wait >3 sec then set value to 0 (Idle).
				0 - 5	Idle (Default to 0)
				6 - 10	Full Luminaire ReCal - also used to wake from shutdown
				11 - 15	Fixture Shutdown
				16 - 20	ReBoot
				21 - 25	Display - Menu On (Will unlock if locked)
				26 - 30	Display - Menu Off
				31 - 35	Reserved
				36 - 40	Dimming Curve Linear
				41 - 45	Dimming Curve S-Curve
				46 - 50	Dimming Curve Square Curve (Default)
				51 - 85	Reserved
				86 - 90	Status Check
				91 - 95	Side Hang Disable (Default)
				96 - 100	Side Hang Enable
				101 - 105	Reserved
				106 - 110	Boost Mode - Fan all activated to 100%, no fan controls
				111 - 115	Standard Mode (Default)
				116 - 120	Studio Mode
				121 - 125	Whisper Mode
				126 - 135	Reserved
				136 - 140	Fan On (Default)
				141 - 145	Fan Auto
				146 - 148	Fan Control On
				149 - 150	Fan Control Off (Default)
				151 - 155	ReCal Position
				156 - 160	ReCal Color
				161 - 165	ReCal Beam
166 - 170	ReCal Optics				
171 - 175	ReCal Gobo				
176 - 180	Reset fixture to defaults				
181 - 195	Reserved				
196	LED Refresh 900Hz				

DMX CHANNEL		PARAMETER	DEFAULTS	RANGE DMX	DESCRIPTION
16-BIT	16-BIT EXTENDED (DEFAULT)				
46	51	Luminaire Control - continued	0	197	LED Refresh 910Hz
				198	LED Refresh 920Hz
				199	LED Refresh 930Hz
				200	LED Refresh 940Hz
				201	LED Refresh 950Hz
				202	LED Refresh 960Hz
				203	LED Refresh 980Hz
				204	LED Refresh 990Hz
				205	LED Refresh 1000Hz
				206	LED Refresh 1500Hz (Default)
				207	LED Refresh 2500Hz
				208	LED Refresh 3000Hz
				209	LED Refresh 3500Hz
				210	LED Refresh 4000Hz
				211	LED Refresh 4500Hz
				212	LED Refresh 5000Hz
				213	LED Refresh 5500Hz
				214	LED Refresh 6000Hz
				215	LED Refresh 6500Hz
				216	LED Refresh 7000Hz
				217	LED Refresh 7500Hz
				218	LED Refresh 8000Hz
				219	LED Refresh 8500Hz
				220	LED Refresh 9000Hz
				221	LED Refresh 10KHz
				222	LED Refresh 10.5KHz
				223	LED Refresh 11KHz
				224	LED Refresh 11.5KHz
				225	LED Refresh 12.5KHz
				226	LED Refresh 13KHz
				227	LED Refresh 13.5KHz
				228	LED Refresh 14KHz
				229	LED Refresh 14.5KHz
				230	LED Refresh 15KHz
231	LED Refresh 16.5KHz				
232	LED Refresh 17KHz				
233	LED Refresh 17.5KHz				
234	LED Refresh 18KHz				

DMX CHANNEL		PARAMETER	DEFAULTS	RANGE DMX	DESCRIPTION
16-BIT	16-BIT EXTENDED (DEFAULT)				
46	54	Luminaire Control - continued	0	235	LED Refresh 18.5KHz
				236	LED Refresh 19KHz
				237	LED Refresh 19.5KHz
				238	LED Refresh 20KHz
				239	LED Refresh 20.5KHz
				240	LED Refresh 21.5KHz
				241	LED Refresh 22KHz
				242	LED Refresh 22.5KHz
				243	LED Refresh 23KHz
				244	LED Refresh 23.5KHz
				245	LED Refresh 24KHz
				246	LED Refresh 24.5KHz
				247	LED Refresh 25KHz
				248 - 255	Reserved

## Timing Channel Values

DMX	% VALUES	TIME (SEC)
0		Full Speed
1		0.2
2		0.4
3	1	0.6
4		0.8
5	2	1
6		1.2
7		1.4
8	3	1.6
9		1.8
10	4	2
11		2.2
12		2.4
13	5	2.6
14		2.8
15	6	3
16		3.2
17		3.4
18	7	3.6
19		3.8
20	8	4
21		4.2
22		4.4
23	9	4.6
24		4.8
25	10	5
26		5.2
27		5.4
28	11	5.6
29		5.8
30		6
31	12	6.2
32		6.4
33	13	6.6
34		6.8
35		7
36	14	7.2
37		7.4
38	15	7.6
39		7.8
40		8
41	16	8.2
42		8.4
43	17	8.6

DMX	% VALUES	TIME (SEC)
44		8.8
45		9
46	18	9.2
47		9.4
48	19	9.6
49		9.8
50		10
51	20	10.2
52		10.4
53		10.6
54	21	11
55		11
56	22	12
57		12
58		13
59	23	13
60		14
61	24	14
62		14
63		15
64	25	15
65		16
66	26	16
67		16
68		17
69	27	17
70		18
71	28	18
72		18
73		19
74	29	19
75		20
76	30	20
77		20
78		21
79	31	21
80		21
81		22
82	32	22
83		23
84	33	23
85		23
86		24
87	34	24

DMX	% VALUES	TIME (SEC)
88		25
89	35	25
90		25
91		26
92	36	26
93		27
94	37	27
95		27
96		28
97	38	28
98		29
99	39	29
100		29
101		30
102	40	30
103		30
104		31
105	41	31
106		32
107	42	32
108		32
109		33
110	43	33
111		34
112	44	34
113		34
114		35
115	45	35
116		36
117	46	36
118		36
119		37
120	47	37
121		38
122	48	38
123		38
124		39
125	49	39
126		39
127		40
128	50	40
129		41
130	51	41
131		41

## Timing Channel Values - continued

DMX	% VALUES	TIME (SEC)
132		42
133	52	42
134		43
135	53	43
136		43
137		44
138	54	44
139		45
140	55	45
141		45
142		46
143	56	46
144		47
145	57	47
146		47
147		48
148	58	48
149		49
150	59	49
151		49
152		50
153	60	50
154		50
155		51
156	61	51
157		52
158	62	52
159		52
160		53
161	63	53
162		54
163	64	54
164		54
165		55
166	65	55
167		56
168	66	56
169		56
170		57
171	67	57
172		58
173	68	58
174		58
175		59

DMX	% VALUES	TIME (SEC)
176	69	59
177		59
178		60
179	70	60
180		65
181	71	65
182		65
183		70
184	72	70
185		75
186	73	75
187		75
188		80
189	74	80
190		85
191	75	85
192		85
193		90
194	76	90
195		95
196	77	95
197		95
198		100
199	78	100
200		110
201	79	110
202		110
203		120
204	80	120
205		120
206	81	130
207		130
208		140
209	82	140
210		140
211		150
212	83	150
213		160
214	84	160
215		160
216		170
217	85	170
218		180
219	86	180

DMX	% VALUES	TIME (SEC)
220		180
221		190
222	87	190
223		200
224	88	200
225		200
226		210
227	89	210
228		210
229		220
230	90	220
231		230
232	91	230
233		230
234		240
235	92	240
236		250
237	93	250
238		250
239		260
240	94	260
241		270
242	95	270
243		270
244		280
245	96	280
246		290
247	97	290
248		290
249		300
250	98	300
251		310
252	99	310
253		310
254		310
255	100	Follows Cue Data

# 4 RDM PARAMETER IDs

Remote Device Management (RDM) is a protocol enhancement to USITT DMX512 that allows bi-directional communication between a lighting or system controller and attached RDM compliant devices over a standard DMX line. This protocol will allow configuration, status monitoring, and management of these devices in such a way that does not disturb the normal operation of standard DMX512 devices that do not recognize the RDM protocol.

VL3600 PROFILE IP SERIES RDM PRODUCT PARAMETER IDS				
Model ID	Manufacturer	Vendor ID	Model Description	Product Category
0x0044	Vari-Lite	0x564C	VL3200 LT PROFILE IP	0x0102

The table on the following pages outlines and describes all the RDM parameters IDs associated with the fixtures.

GET ALLOWED	SET ALLOWED	RDM PARAMETER IDS	VALUE	COMMENT	ESTA STANDARD	REQUIRED / IMPLEMENTED
Category - Network Management						
		DISC_UNIQUE_BRANCH	0x0001		X	X
		DISC_MUTE	0x0002		X	X
		DISC_UN_MUTE	0x0003		X	X
X		PROXIED_DEVICES	0x0010			
X		PROXIED_DEVICES_COUNT	0x0011			
X	X	COMMS_STATUS	0x0015			
Category - Status Collection						
X		QUEUED_MESSAGE	0x0020			
X		STATUS_MESSAGES	0x0030			X
X		STATUS_ID_DESCRIPTION	0x0031			X
	X	CLEAR_STATUS_ID	0x0032			
X	X	SUB_DEVICE_STATUS_REPORT_THRESHOLD	0x0033			
Category - RDM Information						
X		SUPPORTED_PARAMETERS	0x0050		X	X
X		PARAMETER_DESCRIPTION	0x0051		X	X
Category - Product Information						
X		DEVICE_INFO	0x0060		X	X
X		PRODUCT_DETAIL_ID_LIST	0x0070			
X		DEVICE_MODEL_DESCRIPTION	0x0080			X
X		MANUFACTURER_LABEL	0x0081			X
X	X	DEVICE_LABEL	0x0082			X
X	X	FACTORY_DEFAULTS	0x0090			X
X		LANGUAGE_CAPABILITIES	0x00A0			
X	X	LANGUAGE	0x00B0			
X		SOFTWARE_VERSION_LABEL	0x00C0		X	X
X		BOOT_SOFTWARE_VERSION_ID	0x00C1			
X		BOOT_SOFTWARE_VERSION_LABEL	0x00C2			
Category - DMX512 Setup						
X	X	DMX_PERSONALITY	0x00E0			X
X		DMX_PERSONALITY_DESCRIPTION	0x00E1			X
X	X	DMX_START_ADDRESS	0x00F0		X	X
X		SLOT_INFO	0x0120			X
X		SLOT_DESCRIPTION	0x0121			X
X		DEFAULT_SLOT_VALUE	0x0122			X
Category – Sensors 0x02xx						
X		SENSOR_DEFINITION	0x0200			X
X	X	SENSOR_VALUE	0x0201	Fan speed and temperatures		X
	X	RECORD_SENSORS	0x0202			

GET ALLOWED	SET ALLOWED	RDM PARAMETER IDS	VALUE	COMMENT	ESTA STANDARD	REQUIRED / IMPLEMENTED
Category - Dimmer Settings 0x03xx						
X	X	Dimmer Curve	0x0343			X
X		Dimmer Curve Description	0x0344			X
X	X	Modulation Frequency	0x0347			X
X		Modulation Frequency Description	0x0348			X
Category - Power / Lamp Settings 0x04xx						
X	X	DEVICE_HOURS	0x0400			X
X	X	LAMP_HOURS	0x0401			
X	X	LAMP_STRIKES	0x0402			
X	X	LAMP_STATE	0x0403			
X	X	LAMP_ON_MODE	0x0404			
X	X	DEVICE_POWER_CYCLES	0x0405			
Category - Display Settings 0x05xx						
X	X	DISPLAY_INVERT	0x0500			
X	X	DISPLAY_LEVEL	0x0501			
Category - Configuration 0x06xx						
X	X	PAN_INVERT	0x0600			
X	X	TILT_INVERT	0x0601			
X	X	PAN_TILT_SWAP	0x0602			
X	X	REAL_TIME_CLOCK	0x0603			
Category - IP & DNS Configuration 0x07xx						
X		LIST_INTERFACES	0x0700	This is required if any IP setting is used	X*	X
X		INTERFACE_LABEL	0x0701			X
X		INTERFACE_HARDWARE_ADDRESS_TYPE1	0x0702			
X	X	IPV4_DHCP_MODE	0x0703			
X	X	IPV4_ZEROCONF_MODE	0x0704			
X		IPV4_CURRENT_ADDRESS	0x0705			X
X	X	IPV4_STATIC_ADDRESS	0x0706			X
	X	INTERFACE_RENEW_DHCP	0x0707			
	X	INTERFACE_RELEASE_DHCP	0x0708			
	X	INTERFACE_APPLY_CONFIGURATION	0x0709	Required if support 0x0703, 0x0704, or 0x0706	X*	X
X	X	IPV4_DEFAULT_ROUTE	0x070A			
X	X	DNS_IPV4_NAME_SERVER	0x070B			
X	X	DNS_HOSTNAME	0x070C			
X	X	DNS_DOMAIN_NAME	0x070D			
Category - Control 0x10xx						
X	X	IDENTIFY_DEVICE	0x1000		X	X
	X	RESET_DEVICE	0x1001			X

GET ALLOWED	SET ALLOWED	RDM PARAMETER IDS	VALUE	COMMENT	ESTA STANDARD	REQUIRED / IMPLEMENTED
X	X	POWER_STATE	0x1010			
X	X	PERFORM_SELFTEST	0x1020	All Test, Pan/Tilt, Encoder		
X		SELF_TEST_DESCRIPTION	0x1021			
	X	CAPTURE PRESET	0x1030	See E1-20_2010a		
X	X	PRESET PLAYBACK	0x1031	Table A-7 defines		
ESTA Reserved Future RDM			0x7FE0-0x7FFF			
Manufacturer-Specific PIDs			0x8000-0xFFDF			
X	X	Output Power Mode	0x8A97	Value range depends on options (Standard, Studio, etc)		X
X	X	Pan/Tilt Feedback (On/Off)	0x8AD3			
X	X	Display On Time	0x8AA0	Value range depends on options		X
X	X	LED Dimmer Curve	0x8AA1	Value range depends on options		
X	X	Pan Tilt Movement (On/Off)	0x8AA2			
X	X	Head Motor Movement (On/Off)	0x8AA3			
X	X	Auto Shutdown Mode	0x8AA4	Value range depends on options		
X	X	LED Hours	0x8AA5			
X	X	Dim Snap (On/Off)	0x8AA6			
X	X	Color Snap (On/Off)	0x8AA7			
X	X	Auto Fan Mode (On/Off)	0x8AA8			
X	X	Gamma Shift	0x8AA9	Value range depends on options		
X	X	Tungsten Dimming (On/Off)	0x8AAA			
X	X	CTB Correction (On/Off)	0x8AAB			
X	X	LED Refresh Rate	0x8AAC	*** part of section 0x0300 now***		
X	X	Side Hang (On/Off)	0x8AAD			
X	X	Focus Track (On/Off)	0x8AAE			
	X	Control Signal select DMX only/ ARtNET (On/Off)	0x8AAF			
	X	Recalibrate Fixture (Level)	0x8AB0	different levels (all, position, color, etc)		
X	X	DMX Fail (Hold, Blackout, GOTO Preset)	0x8AB1			
X	X	ArtNet Universe	0x8AB2	*** part of section 0x0700 now***		
X	X	ArtNet Net	0x8AB3	*** part of section 0x0700 now***		
X	X	ArtNet Sub-Net	0x8AB4	*** part of section 0x0700 now***		

GET ALLOWED	SET ALLOWED	RDM PARAMETER IDS	VALUE	COMMENT	ESTA STANDARD	REQUIRED / IMPLEMENTED
X	X	ArtNet Ethernet IP	0x8AB5	*** part of section 0x0700 now***		
X	X	ArtNet Ethernet Sub-Net Mask	0x8AB6	*** part of section 0x0700 now***		
X	X	Manual PRESET Playback Power Up Preset	0x8AB7			
X	X	Manual PRESET Playback Preset Intensity	0x8AB8			
X	X	Manual PRESET Playback Priority	0x8AB9			
X	X	Manual PRESET Playback Power Up?	0x8ABA			
X	X	LED Color Calibration (On/Off)	0x8ABB			

# 5 OPERATION

## MENU FUNCTIONS

To access the menu, touch the MENU button. Then use the ARROW buttons to navigate through the menu items in the list. Touch ENTER to select. Repeat as needed to move through the menu lists. Once you have reached your desired selection, use the ARROW buttons to choose or set desired setting and then touch ENTER to store. Touching the MENU button will return to the previous menu level.

The VL3200 LT Profile IP Series Display and Menu System provides local control for accessing the following fixture's settings:

- Address – to set the DMX address
- Configure – various parameter settings, set luminaire ID
- DMX – change the map, view incoming DMX, invert pan/tilt
- Fixture – fixture status, recalibrate, reboot, software version, view fixtures hours, service, etc.
- Test - test functions of parameters
- Manual Preset – edit and set the manual presets within the fixture

The menu system is controlled at the Menu Display available at the enclosure input panel. If there are multiple luminaires in a system, any settings or changes would need to be made at each Menu as desired



**NOTE:** The luminaire has an auto lock function on the Menu Display. To unlock, while touching the ENTER button, touch UP -> DOWN -> UP -> DOWN if unit is sitting. If hanging, while touching the ENTER button, touch DOWN -> UP -> DOWN -> UP.

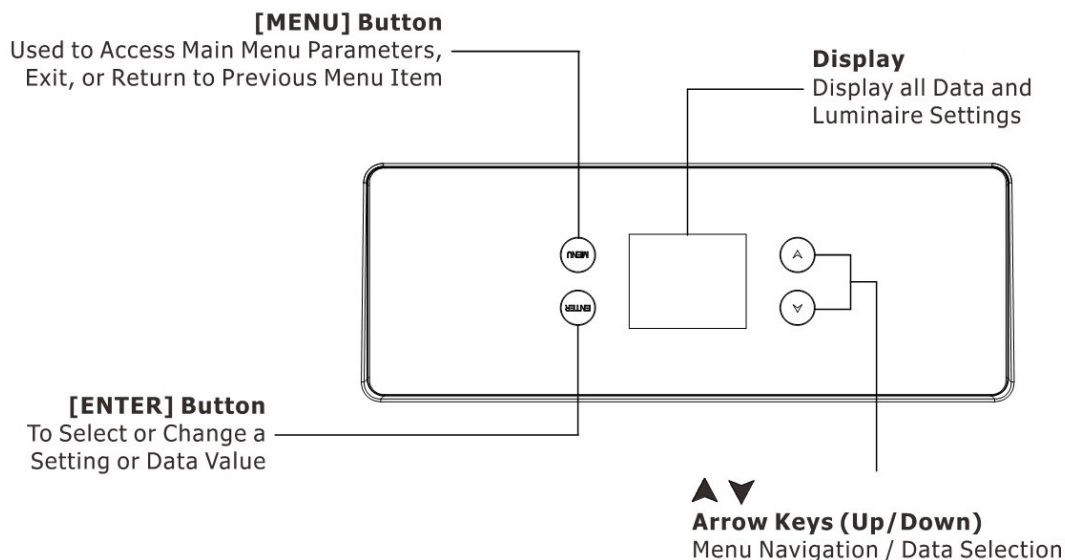

**NOTE:** Menu functions are subject to activation in subsequent software releases. Please check software release notes for details

LEVEL 1	LEVEL 2	LEVEL 3	LEVEL 4	LEVEL 5	LEVEL 6	DEFAULT
Address	001-462 (16 Bit Enhanced) 001-467 (16 Bit)					001
Configure	LED	LED Hours	XXXXXX h			
		Dimming Curve	Square Law			Default
			S Curve			
			Linear			
		Dim Snap	Snap On (Fast)			
			Snap Off (Slow)			Default
		Output Mode	Standard			Default
			Studio			
			Whisper			
		Fan Channel	On			
			Off			Default
		Fan Mode	On			
			Auto			Default
		Refresh Rate	900Hz			
			910Hz			
			920Hz			
			930Hz			
			940Hz			
			950Hz			
			960Hz			
			980Hz			
			990Hz			
			1000Hz			
			1500Hz			Default
			2500Hz			
			3000Hz			
			3500Hz			
			4000Hz			
			4500Hz			
			5000Hz			
			5500Hz			
			6000Hz			
			6500Hz			
7000Hz						
7500Hz						
8000Hz						
8500Hz						
9000Hz						
10KHz						
10.5KHz						
11KHz						
11.5KHz						
12.5KHz						
13KHz						
13.5KHz						
14KHz						

LEVEL 1	LEVEL 2	LEVEL 3	LEVEL 4	LEVEL 5	LEVEL 6	DEFAULT	
Configure Continued	LED Continued	Refresh Rate Continued	14.5KHz				
			15KHz				
			16.5KHz				
			17KHz				
			17.5KHz				
			18KHz				
			18.5KHz				
			19KHz				
			19.5KHz				
			20KHz				
			20.5KHz				
			21.5KHz				
			22KHz				
			22.5KHz				
			23KHz				
			23.5KHz				
			24KHz				
			24.5KHz				
			25KHz				
					Gamma Shift	2.00	
			2.10				
			2.20				
			2.30				
			2.40				
			2.50				
			2.60				
			2.70				
			2.80				
	Movement	Pan/Tilt		Enable			Default
				Disable			
		Side Hang		Enable			
				Disable			Default
	Cal-Position	Home					Default
		DMX					
	Display	Orientation		Up			Default
				Down			
		On time		30 Sec			Default
				5 Min			
				10 Min			
				On			
	Screen Lock (Auto screen lock)		On			Default	
			Off				
Focus Track	Enable						
	Disable					Default	

LEVEL 1	LEVEL 2	LEVEL 3	LEVEL 4	LEVEL 5	LEVEL 6	DEFAULT	
Configure Continued	Follow Spot Mode	Enable				Default	
		Disable					
	Color	Color Snap	Snap off			Default	
			Snap on				
Reset Defaults	Are you sure?						
DMX	Address	001-462 (16 Bit Enhanced) 001-467 (16 Bit)				001	
	DMX Mode	16 Bit Enhanced				Default	
		16 Bit					
	Data	Ch 1 - Intensity XXX (value)					
		Ch 2 - Intensity Fine XXX (value)					
		...All functions					
	Pan/Tilt	Swap Pan/Tilt	Off			Default	
			On				
		Invert Pan	Off			Default	
			On				
		Invert Tilt	Off			Default	
			On				
	Select Signal	DMX Only				Default	
		Wireless DMX	Off			Default	
On							
Wireless DMX	Unlink	No			Default		
		Yes					
DMX Fail	DMX Hold				Default		
	Blackout						
	Goto Preset	1 to 20					
Fixture	Status	No Errors or displays a list of errors					
	ReCal (Fixture)	Are You Sure?					
	Reboot Fixture	Are You Sure?					
	Version	MM/DD/YY					
	Fixture Hours	xxxxxxxh					
	Crossload (Software)	Send					
	Service	USB	Service Settings	Authorized use only. See Service Manual			
			Log File	No USB Device or Are You Sure?		Yes	
				No		No	
				Reset Log		Yes	
				No		No	
			Save Config	No USB Device or Are You Sure?		Yes	
				No		No	
Restore Config			No USB Device or Are You Sure?		Yes		
			No		No		
Save Presets			No USB Device or Are You Sure?		Yes		
			No		No		

LEVEL 1	LEVEL 2	LEVEL 3	LEVEL 4	LEVEL 5	LEVEL 6	DEFAULT		
Fixture Continued	Service Continued	USB Continued	Load Presets	No USB Device or Are You Sure?	Yes			
					No			
			Update OS	NO USB Device or No Update File or MM/DD/YY		Are You Sure?		
		Diagnostics	Fan Check	PowerFan 1: xxxx rpm				
				PowerFan 2: xxxx rpm				
				H/SinkFan1: xxxx rpm				
				H/SinkFan2: xxxx rpm				
				H/SinkFan3: xxxx rpm				
				H/SinkFan4: xxxx rpm				
				LEDFan1: xxxx rpm				
				LEDFan2: xxxx rpm				
				GoboFan: xxxx rpm				
				FrameFan: xxxx rpm				
				HeadFan1: xxxx rpm				
				HeadFan2: xxxx rpm				
P/TFan: xxxx rpm								
			LED Temp	LED: Cur xx °C Max xx °C				
Test	All Test	Run 'ALL TEST'						
	Pan/Tilt Test	Run 'PAN/TILT TEST'						
	Test Channel	Intensity	Run Intensity test					
		Pan	Run Pan test					
		Tilt	Run Tilt test					
		Focus	Run Focus test					
		Zoom	Run Zoom test					
		Cyan	Run Cyan test					
		Yellow	Run Yellow test					
		Magenta	Run Magenta test					
		CTO Wheel	Run CTO test					
		Color Wheel 1	Run Color1 test					
		Gobo Wheel 1	Run Gobo1 test					
		Gobo Wheel 2	Run Gobo2 test					
		Iris	Run Iris test					
		Frame1A	Run Frame1A test					
		Frame1B	Run Frame1B test					
		Frame2A	Run Frame2A test					
		Frame2B	Run Frame2B test					
		Frame3A	Run Frame3A test					
		Frame3B	Run Frame3B test					
		Frame4A	Run Frame4A test					
		Frame4B	Run Frame4B test					
		Frame Rotate	Run FrameR test					
		Prism1	Run Prism1 test					

LEVEL 1	LEVEL 2	LEVEL 3	LEVEL 4	LEVEL 5	LEVEL 6	DEFAULT	
Test Continued	Test Channel Continued	Prism2	Run Prism2 test				
		Frost	Run Frost test				
		Strobe	Run Strobe test				
	Encoder Pan	xxxxxxx - Displays Pan B_Encoder					
		xxxxxxx - Displays Pan M_Encoder					
	Encoder Tilt	xxxxxxx - Displays Tilt B_Encoder					
xxxxxxx - Displays Tilt M_Encoder							
Manual Preset	Playback	Power Up Preset	1 to 20				
		Preset Intensity	0 - 255				255
		Priority	Preset				Default
			DMX				
	Power Up?	Preset Off				Default	
		Preset On					
	Edit	Edit Settings	Load Preset	1 to 20			
			Intensity	0 - 255			
			Strobe	0 - 255			
			Pan	0 - 255			
			Tilt	0 - 255			
			Cyan	0 - 255			
			Yellow	0 - 255			
			Magenta	0 - 255			
			CTO Wheel	0 - 255			
			Color Wheel 1	0 - 255			
			Color Wheel Spin	0 - 255			
			Gobo 1 Selection	0 - 255			
			Gobo 2 Selection	0 - 255			
			Gobo 2 Index/ Rot	0 - 255			
			Animations Wheel	0 - 255			
			Animations Wheel Index/ Rot	0 - 255			
			Prism 1	0 - 255			
			Prism 2	0 - 255			
			Zoom	0 - 255			
			Focus	0 - 255			
			Iris	0 - 255			
			Frost	0 - 255			
			Frame 1A	0 - 255			
			Frame 1B	0 - 255			
Frame 2A			0 - 255				
Frame 2B			0 - 255				
Frame 3A	0 - 255						
Frame 3B	0 - 255						
Frame 4A	0 - 255						

LEVEL 1	LEVEL 2	LEVEL 3	LEVEL 4	LEVEL 5	LEVEL 6	DEFAULT		
Manual Preset Continued	Edit Continued	Edit Settings Continued	Frame 4B	0 - 255				
			Frame Rotate	0 - 255				
			Movement Shape	None	Are You Sure?			
				Figure 8	Are You Sure?			
				Arc	Are You Sure?			
				Line	Are You Sure?			
				Speed	Slow			
					Medium		Default	
			Fast					
			Size	Small				
		Medium			Default			
		Large						
		Store	1 thru 20	Are You Sure?				
		Clear	1 thru 20	Are You Sure?				
		Clear All Presets	Are You Sure?					

## ADDRESS

### ADDRESS

Sets the starting DMX address for the fixture. Can also be set via RDM.

## CONFIGURE

### LED

This menu allows for viewing the LED engine hours, setting the dimming curve, dim snap, output mode, fan channel, fan mode, refresh rate, and gamma.

#### LED Engine Hours

Displays the current LED engine hours.

#### Dimming Curve

Select from Linear, S-Curve and Square Law. Can also be set via the programmer channel and RDM.

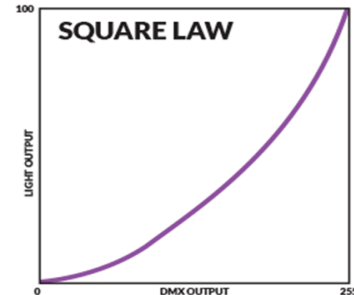
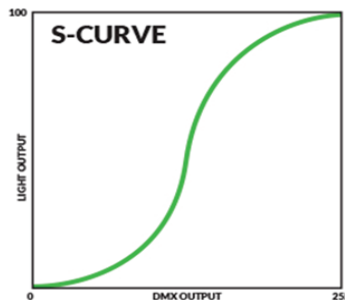
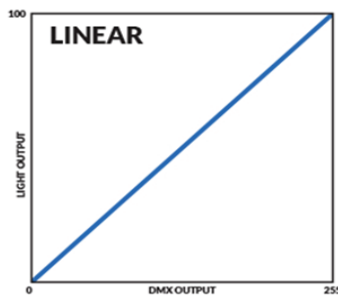

#### Dim Snap

Dim Snap On allows for fastest output changes between levels but reduces smoothness dimming the LED engine. Dim Snap Off ensures all fades between output levels remains smooth and flicker free but limits fast, instant snaps between levels. Can also be set via the programmer channel and RDM.

#### Output Mode

Standard mode provides full LED output. Studio mode reduces fan speed to reduce the fan noise of the fixture. Whisper mode decrease the fan noise further. In both Studio mode and Whisper mode, the LED output will decrease accordingly. Can also be set via the control channel and RDM.

#### Fan Control Channel

By default, the fan control channel is disabled. You can enable the fan control channel by selecting ON from this menu. Can also be enabled or disabled via the control channel.

#### Fan Mode

Fan On runs fans at continuous max speed based on Output Mode. Fan Auto will reduce/increase speed on demand based on LED operating temperature. The fan will not exceed the maximum permissible level based on Output Mode. Can also be set via the control channel and RDM. See Appendix B.

#### Refresh Rate

Choose the refresh rate of the LED engine (see Display Menu Tree for list).

## Gamma Shift

Choose the Gamma shift of the LED engine from 2.00 to 2.80

## MOVEMENT

### Pan/Tilt

Enable allows for the feedback of the encoders to correct the position of pan/tilt in the case of an uncommanded move. Disable prevents this correction, allowing the unit to be positioned by hand.

### Side Hang

Decreases pan/tilt speed when fixture is side hung. Disable should be used when hanging normally.

## CAL-POSITION

### Home

During calibration, pan and tilt will move to the center (50%) of travel. Once calibration has completed, the fixture will move to the current DMX value of pan and tilt.

### DMX

During calibration, pan and tilt will move directly to the current DMX value of pan and tilt.

## DISPLAY

### Orientation

Sets the orientation of the display. Up should be chosen if the fixture is sitting on its base. Down should be chosen if the fixture is hanging.

### On Time

Sets how long the display remains illuminated after the last button touch. Choose from 30 seconds, 5 minutes, 10 minutes, or always on.

### Screen Lock

By default, the screen will auto lock to prevent unauthorized access. This can be disabled by selecting Off.

## FOCUS TRACK

With focus track enabled, once you set a focus (edge) value, running the zoom channel will hold that focus on your image. If you then adjust the focus channel, it will jump to that position based on the DMX value. Disabled will cause the lenses to always move based on the DMX values.

## FOLLOW SPOT MODE

Enabling Follow Spot Mode allows the fixture to be hand positioned without the use of DMX. All other functions are still dependent on DMX control. The pan and tilt motors do provide resistance and breaking. If you disable Follow Spot Mode, the pan and tilt will return to the correct position based on the DMX value.

## COLOR

### Color Snap

Color Snap On allows for faster changes between saturation of colors by allowing the wheels to take the shortest path during a no time move. Color Snap Off forces the wheels to travel through the entire saturation of the color.

## RESET DEFAULTS

Resets all the factory defaults of the fixture. This includes setting the DMX Address to 001. Can also be done via RDM and via the control channel.



**NOTE:** Control channel will not change the current DMX address.

## DMX

### ADDRESS

Sets the starting DMX address of the fixture. Can also be set via RDM.

### DMX MODE

#### 16Bit Enhanced

Includes luminaire timing channels. See DMX map.

#### 16Bit

Omits luminaire timing channels. See DMX map.

### DATA

Allows the current DMX value present on each of the luminaire's DMX channels to be viewed.

### PAN/TILT

#### Swap Pan/Tilt

Choose ON to have the pan mechanism controlled via the tilt DMX channels and vice versa. OFF behaves normally.

#### Invert Pan

Choose ON to reverse the direction of pan. OFF behaves normally.

#### Invert Tilt

Choose ON to reverse the direction of tilt. OFF behaves normally.

### SELECT SIGNAL

#### DMX Only

Fixture only responds to DMX via the onboard XLR connector input.

#### Wireless DMX

Fixture responds to the built in Wireless DMX if set to ON and paired with appropriate transmitter.



**NOTE:** Lumenradio CRMX devices provided by others.

### WIRELESS DMX

VL3200 LT Profile IP Series comes with a built in Wireless DMX receiver. It supports Lumenradio CRMX format. Follow their instructions to configure the transmitter and prepare for pairing.

#### Unlink

If the luminaire has been paired with a transmitter, it will remain paired to that transmitter unless you come to the Unlink options and then choose Yes. At that point, fixture will pair with a transmitter that is in pair mode.

## DMX FAIL

### DMX Hold

If DMX is lost, fixture will maintain its present state until DMX is restored.

### Blackout

If DMX is lost, fixture will go to blackout until DMX is restored.

### Goto Preset

If DMX is lost, fixture will go to the preset (1 through 20).

## FIXTURE

---

### STATUS

Shows list of error message from previous calibration. If none, it will say No Errors.

### RECAL

Runs the calibration routine within the fixture. Can be performed via the control channel or RDM.

### REBOOT FIXTURE

Restarts the entire operating system of the fixture. Can be performed via the control channel or RDM.

### VERSION

Shows the current software version of the fixture. Version is listed in MM/DD/YY format. Can be viewed via RDM.

### FIXTURE HOURS

Shows the accumulated hours the fixture has been powered on. Can be viewed via RDM.

### CROSSLOAD (SOFTWARE)

Allows the current version of software installed in the fixture to be sent to other units via an attached DMX cable.

### SERVICE

#### Service Settings - Password protected

This is for the use of authorized service personnel only. Refer to Service Manual for information.

### USB

#### Log File

Saves a .csv file on the usb drive that contains information about the unit, including settings and previous error messages.

#### Reset Log

Clears the log file so the next time it is recorded will only include items after the file has been cleared.

#### Save Config

Saves the current configuration of the fixture (including all settings) that can then be restored into another fixture (i.e., replacing a unit in a system).

#### Restore Config

Allows the configuration that was saved to the USB in another fixture to be loaded into this fixture. Note the Config needs to have already been loaded onto the USB drive (see previous).

### Save Presets

Stores the current presets on the USB drive. These can then be loaded into a different fixture or back into the same unit.

### Load Presets

Load the saved presets on the USB drive into the current fixture. Note they presets need to have already been loaded onto the USB drive (see previous).

### Update OS

A USB drive may be used to update the firmware of the fixture. Visit [WWW.VARI-LITE.COM](http://WWW.VARI-LITE.COM) to download the latest version. Save to the root level of the USB drive. Install drive into the USB port on the connector panel. Choose Update OS from the menu. Select the version you wish to install and touch [ENTER]. Software will install.

### Diagnostics

#### Fan Check

Displays all fan speeds in RPM.

#### LED Temp

Displays the current and maximum temperature (since the last power cycle) of the LED engine in °C.

## TEST

---

### ALL TEST

Runs the self-test of all functions. To stop the test, press [MENU].

### PAN/TILT TEST

Runs the self-test of pan/tilt. to stop the test, press [MENU].

### TEST CHANNEL

Choose the function you wish to test from the list and touch [ENTER]. The self-test will run. To stop the test touch [MENU].

### ENCODER PAN

Displays the value of the two absolute value encoders for pan. Pan M displays the value of the motor encoder, and Pan B displays the secondary pan encoder. If pan/tilt movement is enabled, the fixture will return to previous position after movement.

### ENCODER TILT

Displays the value of the two absolute value encoders for tilt. Tilt M displays the value of the motor encoder, and Tilt B displays the secondary tilt encoder. If pan/tilt movement is enabled, the fixture will return to previous position after movement.

## MANUAL PRESET

---

### PLAYBACK

#### Power Up Preset

Selects the preset (1 to 20) that will be played back after power up if enabled.

#### Preset Intensity

Selects the master intensity of a preset being played back (0 to 255).

## Priority

Choose Preset if you always want a preset to playback. Choose DMX if you only want a preset to playback if there is no DMX present.

## Power Up?

Choose Preset On if you want the fixture to playback the preset at power up. Choose Preset Off if you do not want a preset to play.

## EDIT

### Load Preset

Select from preset 1 to 20 and touch [ENTER]. That preset will be played back.

### Edit Settings

Choose the function from the list you wish to edit and touch [ENTER]. Use the [UP]/[DOWN] buttons to set desired value. Touch [ENTER] to store. Then continue to adjust all function desired. Movement Shape allows you to select from 3 preset movement effects (Figure 8, Arc, Line) and also set the speed (slow, medium, fast) and size (small, medium, large). Choose none if no movement effect is desired.

### Store

After setting all your functions, select which preset number you wish to store (1 to 20) and touch [ENTER]. Touch [ENTER] again to confirm when prompted.

### Clear

Select the preset (1 to 20) you wish to clear and touch [ENTER]. Touch [ENTER] again to confirm when prompted.

### Clear All Presets

When prompted, touch [ENTER] to confirm and all presets (1 to 20) will be erased.



---

---

**WARNING:** Clearing the presets CANNOT be undone!

---

---

Presets can also be stored via a DMX controller using the control channel.

# APPENDIX A

# CARE AND MAINTENANCE

## TROUBLESHOOTING

---

### The unit does not work; light and fan do not turn on

- Check the connection of power and main fuse.
- Measure the mains voltage on the main connector.

### Not responding to DMX controller

- Check DMX connectors, cables to see if they link properly.
- Check the address settings and DMX polarity.
- If you have intermittent DMX signal problems, check the pins on connectors or on DMX PCB of the unit or the previous one.
- Try to use another DMX controller.
- Check if the DMX cables run near or run alongside to high voltage cables that may cause damage or interference to DMX interface circuit.

## CLEANING

---

The cleaning of internal lenses must be carried out periodically to optimize light output. Cleaning frequency depends on the environment in which the fixture operates damp, smoky or particularly dirty surrounding can cause greater accumulation of dirt on the fixture's optics.

General cleaning guidelines:

- Clean with soft cloth using normal glass cleaning fluid.
- Always dry the parts carefully.
- Clean the external optics at least every 30 days.

## CLEANING OPTICS, FILTERS AND GOBOS



**WARNING:** Remove power from luminaires before performing maintenance.



**WARNING:** Acetone is a harsh cleaning agent and solvent. Acetone is very flammable.

Handle acetone according to manufacturer's safety instructions and precautions.

The front lens, optics/color filters may require cleaning after extended use.

- FRONT LENS: Use a isopropyl alcohol with a soft, lint-free cloth to clean the front lens.
- OPTICS/COLOR FILTERS/ GOBOS: Use Acetone or Isopropyl Alcohol along with a soft, lint-free cloth to clean the optics/color filters.



**CAUTION:** Do not continuously rub color filters or reflector - it may damage or remove the optical coating.

# APPENDIX B

## FAN SPEED AND CONTROL

### ADDENDUM

#### FAN SPEED AND CONTROL

All Vari-Lite luminaires will be governed by the same fan speed vs. noise levels vs. maximum power output rules as detailed below. The noise related to these levels will conform to the Noise Criteria levels, details of which are contained within this document.

There are three control parameters that can be selected separately or in conjunction (when permitted) to manage fan speed vs. noise levels vs. maximum power output.

**NOTE:** Not all fixtures have all modes or functions. Refer to DMX map and User Interface menu tree to see if your product has one or more of these functions.

#### Output Modes

These modes are selectable at the fixture's DMX control channel or via the fixture's user interface screen.

**Boost mode** - LED output boosted to >100% of standard output. Fan speeds increased to manage heat level of LED (may be limited to only run for XX hours). Fixture will not exceed NC45-NC55 sound levels in this mode.

**Standard mode** - Full LED output. Fan speed is set to cool LED appropriately but not exceed NC40 sound level in this mode.

**Studio mode** - Fan speed reduced to achieve 10% dB reduction from Standard mode and not exceed NC35 sound level. LED output is approximately 80% of Standard output to ensure LEDs operate at optimum temperature and output efficiency. Fan speed remains constant and does not ramp up or down.

**Whisper mode** - Fan speed reduced to achieve 30% dB reduction from Standard mode and not exceed NC25 sound level. LED output is approximately 60% of Standard output to ensure LEDs operate at optimum temperature and output efficiency. Fan speed remains constant and does not ramp up or down.

**Silent mode** - fans are turned off or turn very slowly to not contribute to fixture noise. LED output is capped to ensure LEDs operate at optimum temperature and output efficiency. Fans are either off or fan speed remains constant. Target NC15 sound level in this mode.

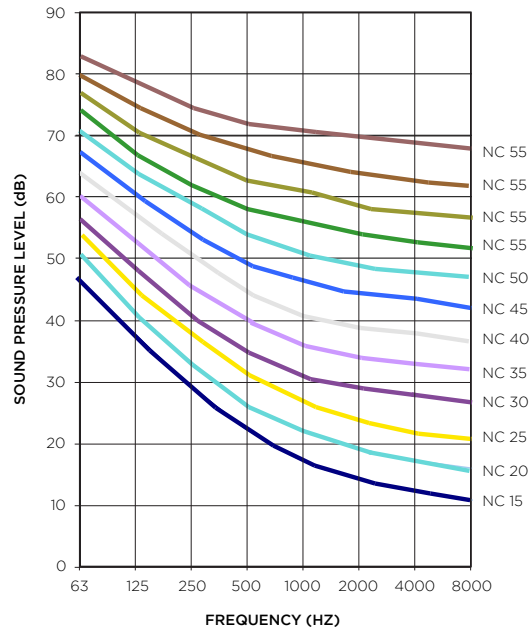

MODE	LED OUTPUT	FAN SPEED	NOISE CRITERION	EQUIVALENT SOUND LEVEL DBA (@3M)
Boost Mode	>100%	Boosted fan speed constant	NC45	50
Standard Mode	Full 100%	Full 100% constant	NC40	45
Studio Mode	80%	Appropriate speed to reduce dB levels >10% of full speed	NC35	40
Whisper Mode	60%	Appropriate speed to reduce dB levels >30% of full speed	NC25	35
Silent Mode	TBC	Fan off	NC15	25

NOISE CRITERION	OCTAVE BAND CENTER FREQUENCY (HZ)							
	63	125	250	500	1000	2000	4000	8000
	SOUND PRESSURE LEVELS (DB)							
NC-15	47	36	29	22	17	14	12	11
NC-20	51	40	33	26	22	19	17	16
NC-25	54	44	37	31	27	24	22	21
NC-30	57	48	41	35	31	29	28	27
NC-35	60	52	45	40	36	34	33	32
NC-40	64	56	50	45	41	39	38	37
NC-45	67	60	54	49	46	44	43	42
NC-50	71	64	58	54	51	49	48	47
NC-55	74	67	62	58	56	54	53	52
NC-60	77	71	67	63	61	59	58	57
NC-65	80	75	71	68	66	64	63	62
NC-70	83	79	75	72	71	70	69	68

# TECHNICAL SUPPORT

## GLOBAL 24HR TECHNICAL SUPPORT:

Call: +1 214 647 7880

[entertainment.service@signify.com](mailto:entertainment.service@signify.com)

## NORTH AMERICA SUPPORT:

Call: 877-VARI-LITE (877-827-4583)

[entertainment.service@signify.com](mailto:entertainment.service@signify.com)

## EUROPEAN CUSTOMER SERVICE:

[entertainment.europe@signify.com](mailto:entertainment.europe@signify.com)

©2026 Signify Holding. All rights reserved.

All trademarks are owned by Signify Holding or their respective owners. The information provided herein is subject to change, without notice. Signify does not give any representation or warranty as to the accuracy or completeness of the information included herein and shall not be liable for any action in reliance thereon. The information presented in this document is not intended as any commercial offer and does not form part of any quotation or contract, unless otherwise agreed by Signify. Data subject to change.

VL3200 PROFILE LT IP USER MANUAL

DOCUMENT NUMBER: REV A

VERSION DATE: APRIL 29 2026